

Technical Support Center: Overcoming 44-Homooligomycin B Insolubility

Author: BenchChem Technical Support Team. **Date:** April 2026

Compound of Interest

Compound Name: 44-Homooligomycin B

Cat. No.: B15565327

[Get Quote](#)

This technical support center provides troubleshooting guides and frequently asked questions (FAQs) to assist researchers, scientists, and drug development professionals in overcoming the challenges associated with the poor aqueous solubility of **44-Homooligomycin B** and related compounds.

Troubleshooting Guide

Issue: Precipitate formation when diluting stock solution into aqueous media.

Possible Cause 1: Low solubility of **44-Homooligomycin B** in aqueous solutions.

- Solution: **44-Homooligomycin B**, similar to other oligomycins, is practically insoluble in water.[1] To work with it in aqueous-based assays, it is essential to first dissolve it in an appropriate organic solvent to create a concentrated stock solution.

Possible Cause 2: The concentration in the final aqueous solution is too high.

- Solution: After preparing a stock solution in an organic solvent, dilute it into your aqueous experimental buffer or media to the final desired concentration. It is crucial to ensure that the

final concentration does not exceed the solubility limit in the aqueous medium. For a related compound, Oligomycin A, a 1:2 solution of ethanol to PBS (pH 7.2) yielded a solubility of approximately 0.3 mg/mL.[2]

Possible Cause 3: Instability of the compound in aqueous solution over time.

- Solution: Aqueous solutions of oligomycins are not stable for long periods. It is recommended to prepare fresh dilutions for each experiment and use them immediately.[2] Avoid storing aqueous solutions of the compound.

Issue: Inconsistent experimental results.

Possible Cause 1: Incomplete dissolution of the compound.

- Solution: Ensure the compound is fully dissolved in the organic solvent before preparing the stock solution. Gentle warming to 37°C or sonication can aid in dissolution.

Possible Cause 2: Degradation of the compound.

- Solution: Store the solid compound and stock solutions at -20°C, protected from light.[3] For stock solutions in DMSO, it is advisable to aliquot them to avoid repeated freeze-thaw cycles, which can degrade the compound.[3] Once in solution, use within 3 months to prevent loss of potency.

Frequently Asked Questions (FAQs)

Q1: In which solvents is **44-Homooligomycin B** soluble?

While specific data for **44-Homooligomycin B** is limited, based on its structural similarity to other oligomycins, it is expected to be soluble in organic solvents such as Dimethyl Sulfoxide (DMSO), ethanol, methanol, and dimethylformamide (DMF). It is practically insoluble in water.

Q2: How do I prepare a stock solution of **44-Homooligomycin B**?

To prepare a stock solution, dissolve the compound in a suitable organic solvent like DMSO or ethanol. For example, a stock solution of Oligomycin can be prepared in DMSO at a concentration of 5 mM by reconstituting 5 mg in 1.26 ml of DMSO.

Q3: What is the recommended method for diluting the stock solution into my aqueous experimental medium?

For maximum solubility in aqueous buffers, it is recommended to first dissolve the compound in ethanol. This ethanolic stock solution can then be diluted with the aqueous buffer of choice to the final working concentration.

Q4: What is the stability of **44-Homooligomycin B** in solution?

Stock solutions in organic solvents like DMSO or ethanol are relatively stable when stored properly at -20°C and protected from light. However, aqueous dilutions are not stable and should be prepared fresh for each experiment and used immediately.

Quantitative Solubility Data for Oligomycins

The following table summarizes the solubility of various oligomycins in different solvents. This data can be used as a reference for preparing solutions of **44-Homooligomycin B**.

Compound	Solvent	Solubility	Reference
Oligomycin A	DMSO	~20 mg/mL, 100 mg/mL	
Oligomycin A	Ethanol	~30 mg/mL, Soluble to 10 mM	
Oligomycin A	Dimethyl formamide (DMF)	~30 mg/mL	
Oligomycin A	Water	Insoluble	
Oligomycin B	DMSO	Soluble	
Oligomycin B	Ethanol	Soluble	
Oligomycin B	Methanol	Soluble	
Oligomycin B	Dimethyl formamide (DMF)	Soluble	
Oligomycin B	Water	Practically insoluble	
Oligomycin (mixture)	DMSO	50 mg/mL, 300 mg/mL	
Oligomycin (mixture)	Ethanol	250 mg/mL, 200 mg/mL	

Experimental Protocol: Preparation of an Aqueous Working Solution

This protocol provides a general method for preparing an aqueous working solution of **44-Homooligomycin B** from a stock solution in an organic solvent.

- Prepare a Stock Solution:
 - Accurately weigh the desired amount of **44-Homooligomycin B**.
 - Dissolve it in a minimal amount of a water-miscible organic solvent (e.g., DMSO or ethanol) to achieve a high-concentration stock solution (e.g., 10 mM).

- Ensure the compound is completely dissolved. Gentle vortexing or brief sonication may be used.
- Prepare the Aqueous Working Solution:
 - Determine the final concentration of **44-Homooligomycin B** required for your experiment.
 - Serially dilute the stock solution into your pre-warmed (e.g., 37°C) aqueous experimental medium (e.g., cell culture medium or buffer).
 - It is crucial to add the stock solution to the aqueous medium while vortexing to ensure rapid and uniform mixing, which can help prevent precipitation.
 - The final concentration of the organic solvent in the aqueous solution should be kept to a minimum (typically $\leq 0.1\%$) to avoid solvent-induced artifacts in biological assays.
- Use Immediately:
 - Use the freshly prepared aqueous working solution immediately in your experiment. Do not store aqueous dilutions.

Visualizations

Experimental Workflow for Using Hydrophobic Compounds

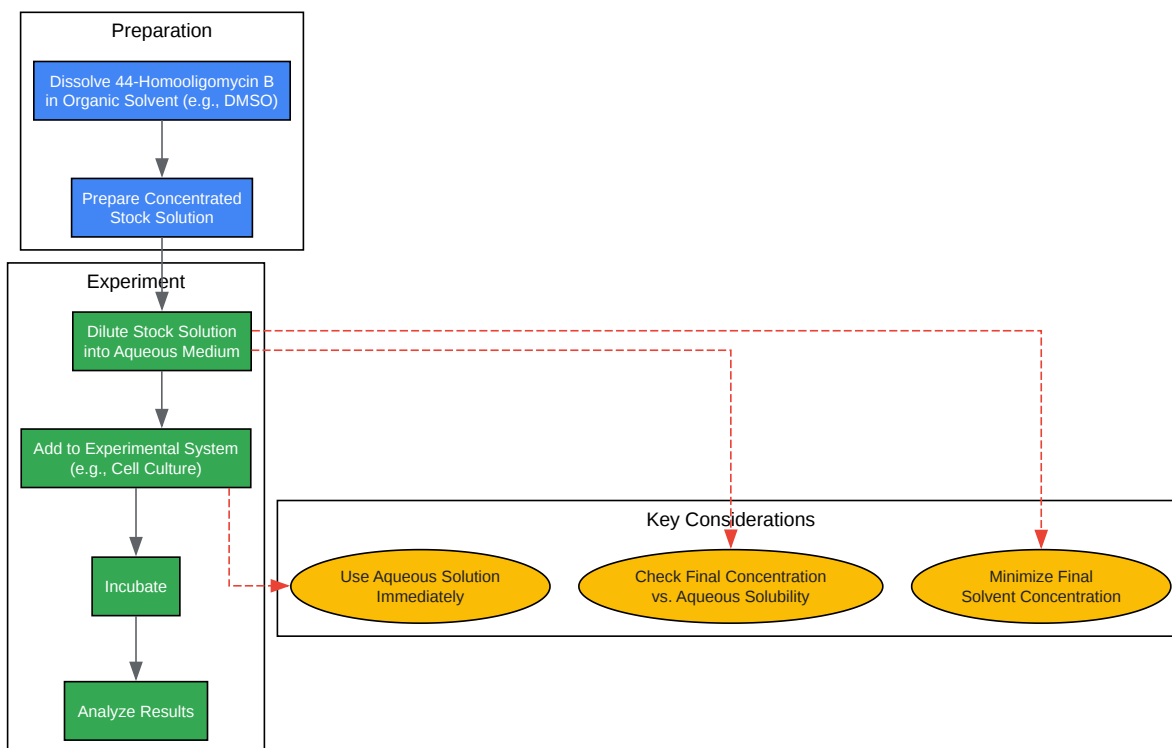

Mechanism of Action of Oligomycin

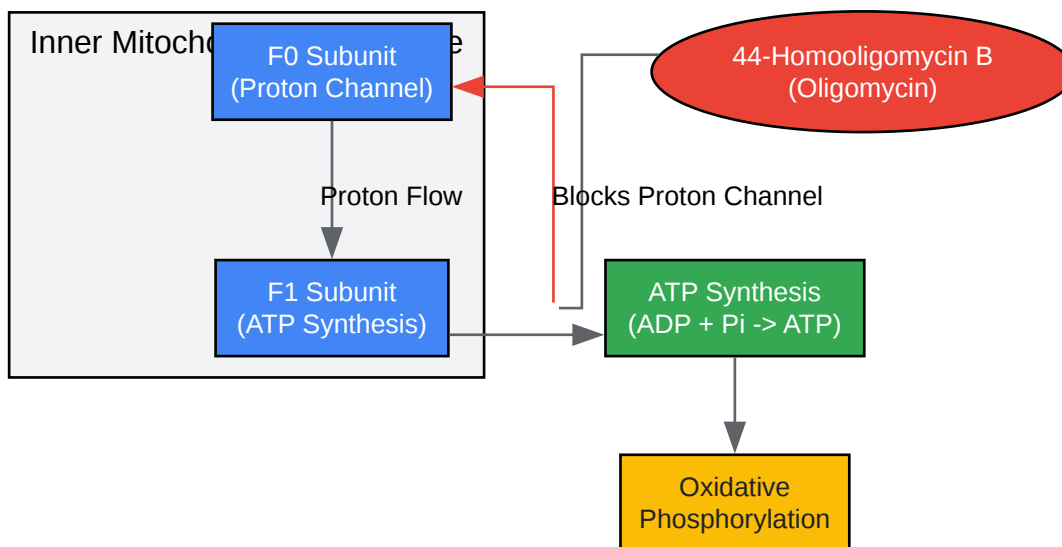

[Click to download full resolution via product page](#)

Need Custom Synthesis?

BenchChem offers custom synthesis for rare earth carbides and specific isotopic labeling.

Email: info@benchchem.com or [Request Quote Online](#).

References

- 1. toku-e.com [toku-e.com]
- 2. cdn.caymanchem.com [cdn.caymanchem.com]
- 3. Oligomycin | Cell Signaling Technology [cellsignal.com]
- To cite this document: BenchChem. [Technical Support Center: Overcoming 44-Homooligomycin B Insolubility]. BenchChem, [2026]. [Online PDF]. Available at: [\[https://www.benchchem.com/product/b15565327/docs#technical-support-center-overcoming-44-homooligomycin-b-insolubility\]](https://www.benchchem.com/product/b15565327/docs#technical-support-center-overcoming-44-homooligomycin-b-insolubility)

Disclaimer & Data Validity:

The information provided in this document is for Research Use Only (RUO) and is strictly not intended for diagnostic or therapeutic procedures. While BenchChem strives to provide

accurate protocols, we make no warranties, express or implied, regarding the fitness of this product for every specific experimental setup.

Technical Support: The protocols provided are for reference purposes. Unsure if this reagent suits your experiment?

Need Industrial/Bulk Grade? [Request Custom Synthesis Quote](#)

BenchChem

Our mission is to be the trusted global source of essential and advanced chemicals, empowering scientists and researchers to drive progress in science and industry.

Contact

Address: 3281 E Guasti Rd

Ontario, CA 91761, United States

Phone: (601) 213-4426

Email: info@benchchem.com

[Contact our Ph.D. Support Team for a compatibility check](#)