

Technical Support Center: Inconsistent Results with PI-1840 In Vitro

Author: BenchChem Technical Support Team. **Date:** April 2026

Compound of Interest

Compound Name: PI-1840
Cat. No.: B15565279

[Get Quote](#)

Welcome to the technical support center for **PI-1840**. This resource is designed for researchers, scientists, and drug development professionals to provide troubleshooting guidance and answers to frequently asked questions regarding the in vitro use of **PI-1840**, a potent, selective, and reversible non-covalent proteasome inhibitor.

Frequently Asked Questions (FAQs)

Q1: What is **PI-1840** and what is its mechanism of action?

A1: **PI-1840** is a cell-permeable, non-covalent and rapidly reversible proteasome inhibitor.[1] It exhibits high selectivity for the chymotrypsin-like (CT-L) activity of the $\beta 5$ subunit of the 20S proteasome.[2] By inhibiting the proteasome, **PI-1840** prevents the degradation of various cellular proteins, including key regulators of the cell cycle and apoptosis.[1] This leads to the accumulation of proteasome substrates such as p27, Bax, and I κ B- α , which in turn can induce cell cycle arrest and apoptosis in cancer cells.[2][3]

Q2: I am observing inconsistent IC50 values for **PI-1840** between experiments. What are the potential causes?

A2: Inconsistent IC50 values are a common issue in in vitro studies and can arise from several factors:

- **Cell Line Specificity:** Different cell lines exhibit varying sensitivity to proteasome inhibitors. This can be due to differences in the expression levels of proteasome subunits, dependence on the proteasome for survival, or the status of key signaling pathways (e.g., p53).[\[4\]](#)[\[5\]](#)[\[6\]](#)
- **Compound Solubility and Stability:** **PI-1840** is insoluble in water.[\[2\]](#) Improperly prepared or stored stock solutions can lead to precipitation and inaccurate concentrations. It is crucial to ensure the compound is fully dissolved in a suitable solvent like DMSO.
- **Experimental Conditions:** Variations in cell seeding density, incubation time, and serum concentration in the culture medium can all significantly impact the apparent IC50 value.[\[7\]](#)
- **Cell Health and Passage Number:** The health and passage number of your cells can affect their response to treatment. Use cells at a consistent and low passage number and ensure they are healthy and actively dividing before starting an experiment.

Q3: My cells are showing high levels of toxicity even at low concentrations of **PI-1840**. What should I do?

A3: High toxicity at low concentrations could be due to:

- **High Cell Sensitivity:** Some cell lines are inherently more sensitive to proteasome inhibition.
- **Solvent Toxicity:** Ensure the final concentration of the solvent (e.g., DMSO) in your cell culture medium is at a non-toxic level (typically $\leq 0.5\%$).
- **Incorrect Concentration:** Double-check your calculations for stock solution and dilutions.

To troubleshoot this, you should:

- Perform a dose-response experiment with a wider and lower range of concentrations to determine the optimal non-toxic concentration for your specific cell line.
- Reduce the incubation time with the inhibitor.

- Run a vehicle control (media with the same final concentration of DMSO) to assess the toxicity of the solvent alone.

Q4: I am not observing the expected accumulation of proteasome substrates (e.g., p27, Bax) after **PI-1840** treatment. What could be wrong?

A4: Several factors could contribute to this observation:

- Ineffective Proteasome Inhibition: The concentration of **PI-1840** may be too low, or the incubation time too short to achieve sufficient proteasome inhibition in your specific cell line.
- Alternative Degradation Pathways: The protein of interest might be degraded by other cellular pathways, such as the lysosomal pathway.
- Antibody Issues: The primary antibody used for Western blotting may not be optimal. Ensure your antibody is validated for the detection of your protein of interest.
- Protein Extraction and Handling: Ensure that your lysis buffer contains protease and phosphatase inhibitors to prevent protein degradation during sample preparation.

Troubleshooting Guide

This guide provides a systematic approach to resolving common issues encountered during in vitro experiments with **PI-1840**.

Problem	Possible Cause	Suggested Solution
Inconsistent Cell Viability Results (e.g., variable IC50)	Compound Precipitation: PI-1840 is insoluble in aqueous solutions and may precipitate when diluted in cell culture medium.	Prepare a high-concentration stock solution in 100% DMSO. When preparing working solutions, ensure the final DMSO concentration in the medium is low and consistent across experiments. Visually inspect for any precipitation after dilution.
Cell Culture Variability: Differences in cell passage number, confluency, or growth phase can alter sensitivity.	Standardize cell culture procedures. Use cells within a defined passage number range and seed them at a consistent density to ensure they are in the logarithmic growth phase during the experiment.	
Assay Conditions: Variations in incubation time or reagent preparation.	Adhere strictly to a standardized protocol for all assays. Include appropriate positive and negative controls in every experiment.	
Low or No Observable Effect on Cells	Inhibitor Inactivity: Improper storage or handling may have led to the degradation of PI-1840.	Store the solid compound and stock solutions at -20°C or -80°C, protected from light and moisture. Prepare fresh working solutions for each experiment.
Cell Line Resistance: The chosen cell line may be resistant to proteasome inhibition.	Confirm the p53 status of your cell line, as p53 wild-type cells may be more sensitive. ^[3] Consider using a different cell line known to be sensitive to	

	proteasome inhibitors as a positive control.	
High Background in Proteasome Activity Assays	Nonspecific Protease Activity: Cell lysates contain other proteases that can cleave the fluorogenic substrate.	Use a proteasome-specific substrate. Consider using a commercial assay kit that includes inhibitors for non-specific proteases.
Autofluorescence: The compound itself may be fluorescent at the wavelengths used in the assay.	Run a control with PI-1840 in the assay buffer without cell lysate to check for background fluorescence.	

Quantitative Data Summary

The following table summarizes the reported inhibitory concentrations of **PI-1840**.

Parameter	Value	Assay Condition	Reference
IC50 (Chymotrypsin-like activity)	27 nM	Purified rabbit 20S proteasome	[2]
IC50 (Cell Viability - MG-63 cells)	108.40 μ M	24 hours	[8]
59.58 μ M	48 hours	[8]	
IC50 (Cell Viability - U2-OS cells)	86.43 μ M	24 hours	[8]
38.83 μ M	48 hours	[8]	
IC50 (Cell Viability - MDA-MB-468 cells)	0.37 μ M	Intact cells	[2]

Experimental Protocols

Protocol 1: Preparation of PI-1840 Stock Solution

- Reconstitution: **PI-1840** is soluble in DMSO at a concentration of 78 mg/mL (197.73 mM) and in ethanol at 33 mg/mL (83.65 mM).[2] It is insoluble in water.[2]
- Stock Solution Preparation: For a 10 mM stock solution, dissolve 3.94 mg of **PI-1840** (MW: 394.47 g/mol) in 1 mL of 100% DMSO.
- Storage: Aliquot the stock solution into single-use vials to avoid repeated freeze-thaw cycles and store at -20°C or -80°C, protected from light.

Protocol 2: Cell Viability Assay (CCK-8)

This protocol is adapted for osteosarcoma cell lines MG-63 and U2-OS.[8][9][10]

- Cell Seeding: Seed cells in a 96-well plate at a density of 5×10^3 cells/well and incubate for 12 hours to allow for cell attachment.
- Treatment: Treat cells with various concentrations of **PI-1840** (e.g., 0, 5, 10, 20, 40, 80, and 160 μ M) for 24 or 48 hours. Include a vehicle control (DMSO).
- CCK-8 Addition: Add 10 μ L of CCK-8 solution to each well and incubate for 1-4 hours at 37°C.
- Measurement: Measure the absorbance at 450 nm using a microplate reader.
- Data Analysis: Calculate the cell viability as a percentage of the vehicle-treated control.

Protocol 3: Apoptosis Analysis (Annexin V-FITC/PI Staining)

- Cell Seeding and Treatment: Seed cells in 6-well plates at a density of 1×10^6 cells/well and allow them to attach overnight. Treat the cells with the desired concentrations of **PI-1840** for the specified time.
- Cell Harvesting: Harvest the cells by trypsinization and wash them with cold PBS.
- Staining: Resuspend the cells in 1X Binding Buffer. Add Annexin V-FITC and Propidium Iodide (PI) and incubate in the dark.

- Flow Cytometry: Analyze the stained cells by flow cytometry.

Protocol 4: Western Blot Analysis for Proteasome Substrate Accumulation

- Cell Treatment: Treat cells with **PI-1840** at the desired concentrations and for the appropriate duration.
- Cell Lysis: Wash cells with ice-cold PBS and lyse them in RIPA buffer supplemented with protease and phosphatase inhibitors.
- Protein Quantification: Determine the protein concentration of the lysates using a BCA or Bradford assay.
- SDS-PAGE and Transfer: Separate equal amounts of protein on an SDS-PAGE gel and transfer to a PVDF or nitrocellulose membrane.
- Immunoblotting: Block the membrane and then incubate with primary antibodies against proteins of interest (e.g., p27, Bax, I κ B- α , and a loading control like GAPDH or β -actin). Follow with incubation with an appropriate HRP-conjugated secondary antibody.
- Detection: Visualize the protein bands using an enhanced chemiluminescence (ECL) detection system.

Visualizations

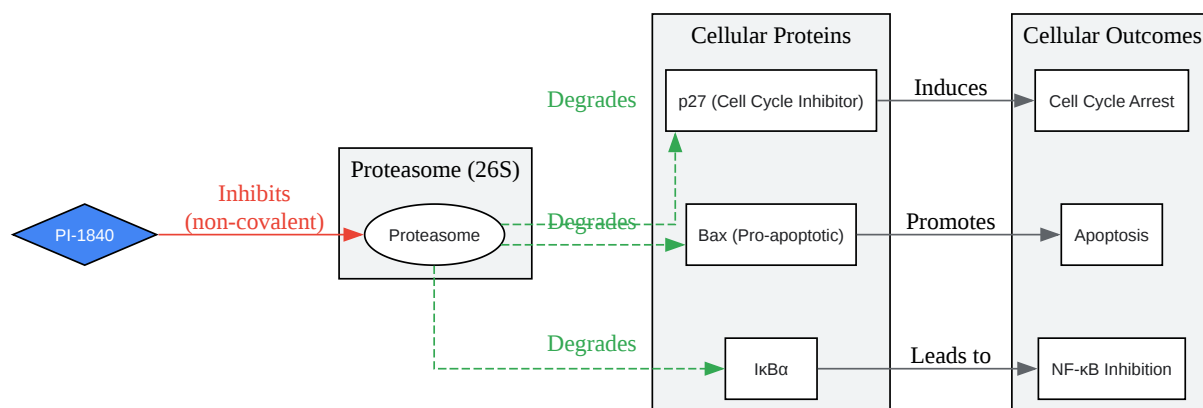

[Click to download full resolution via product page](#)

PI-1840 Signaling Pathway

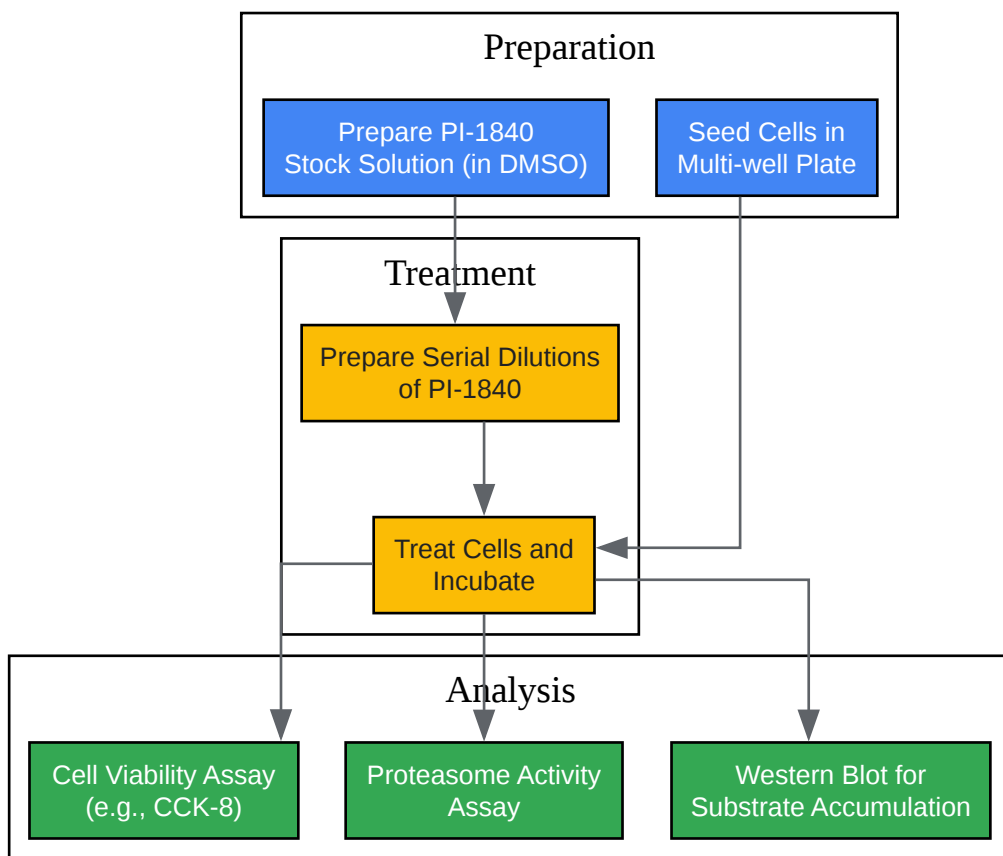

[Click to download full resolution via product page](#)

General Experimental Workflow

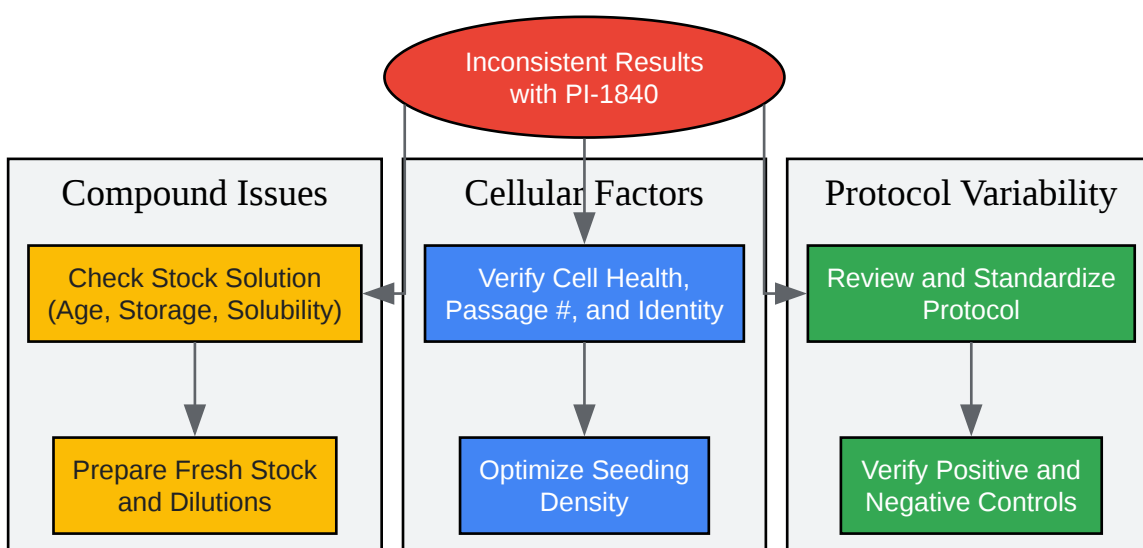

[Click to download full resolution via product page](#)

Troubleshooting Decision Tree

Need Custom Synthesis?

BenchChem offers custom synthesis for rare earth carbides and specific isotopic labeling.

Email: info@benchchem.com or [Request Quote Online](#).

References

- 1. Discovery of PI-1840, a novel noncovalent and rapidly reversible proteasome inhibitor with anti-tumor activity - PubMed [pubmed.ncbi.nlm.nih.gov]
- 2. selleckchem.com [selleckchem.com]
- 3. Discovery of PI-1840, a Novel Noncovalent and Rapidly Reversible Proteasome Inhibitor with Anti-tumor Activity - PMC [pmc.ncbi.nlm.nih.gov]
- 4. Factors determining the sensitivity to proteasome inhibitors of multiple myeloma cells - PubMed [pubmed.ncbi.nlm.nih.gov]
- 5. The proteasomal and apoptotic phenotype determine bortezomib sensitivity of non-small cell lung cancer cells - PMC [pmc.ncbi.nlm.nih.gov]
- 6. Factors determining the sensitivity to proteasome inhibitors of multiple myeloma cells - PMC [pmc.ncbi.nlm.nih.gov]
- 7. benchchem.com [benchchem.com]
- 8. Non-covalent proteasome inhibitor PI-1840 induces apoptosis and autophagy in osteosarcoma cells - PMC [pmc.ncbi.nlm.nih.gov]
- 9. Non-covalent proteasome inhibitor PI-1840 induces apoptosis and autophagy in osteosarcoma cells - PubMed [pubmed.ncbi.nlm.nih.gov]
- 10. pdfs.semanticscholar.org [pdfs.semanticscholar.org]
- To cite this document: BenchChem. [Technical Support Center: Inconsistent Results with PI-1840 In Vitro]. BenchChem, [2026]. [Online PDF]. Available at: [<https://www.benchchem.com/product/b15565279/docs#technical-support-center-inconsistent-results-with-pi-1840-in-vitro>]

Disclaimer & Data Validity:

The information provided in this document is for Research Use Only (RUO) and is strictly not intended for diagnostic or therapeutic procedures. While BenchChem strives to provide accurate protocols, we make no warranties, express or implied, regarding the fitness of this product for every specific experimental setup.

Technical Support: The protocols provided are for reference purposes. Unsure if this reagent suits your experiment?

Need Industrial/Bulk Grade? [Request Custom Synthesis Quote](#)

BenchChem

Our mission is to be the trusted global source of essential and advanced chemicals, empowering scientists and researchers to drive progress in science and industry.

Contact

Address: 3281 E Guasti Rd
Ontario, CA 91761, United States
Phone: (601) 213-4426
Email: info@benchchem.com

[Contact our Ph.D. Support Team for a compatibility check](#)