

Optimizing A201A concentration for in vitro experiments

Author: BenchChem Technical Support Team. **Date:** April 2026

Compound of Interest

Compound Name: A201A
Cat. No.: B15565319

[Get Quote](#)

Technical Support Center: A201A In Vitro Applications

This technical support center provides guidance for researchers, scientists, and drug development professionals on the use of **A201A** in in vitro experiments.

Disclaimer: Current scientific literature primarily describes **A201A** as a nucleoside antibiotic with activity against various bacteria. Its mechanism of action is the inhibition of protein synthesis by preventing tRNA accommodation in the ribosome. Information regarding the effects of **A201A** on eukaryotic cells, including cytotoxicity data (e.g., IC50 values) in cancer cell lines or its influence on specific signaling pathways, is not extensively available in publicly accessible research. Therefore, this guide focuses on its application as an antibacterial agent.

Frequently Asked Questions (FAQs)

Q1: What is **A201A** and what is its mechanism of action?

A201A is a nucleoside antibiotic produced by the marine actinomycete *Marinactinospora thermotolerans* and formerly by *Streptomyces capreolus*.^{[1][2]} Its primary mechanism of action

is the inhibition of bacterial protein synthesis. It achieves this by binding to the bacterial ribosome and inhibiting the accommodation of aminoacyl-tRNA into the A-site, thereby halting peptide chain elongation.

Q2: What is the typical effective concentration range for **A201A** in antibacterial assays?

The effective concentration of **A201A** will vary depending on the bacterial species and the specific assay conditions. It is recommended to perform a dose-response experiment, such as a Minimum Inhibitory Concentration (MIC) assay, to determine the optimal concentration for your specific strain of interest. A starting range for such an assay could be from 0.1 µg/mL to 100 µg/mL.

Q3: Can **A201A** be used in eukaryotic cell culture experiments?

There is currently a lack of published data on the effects of **A201A** on eukaryotic cells. As an inhibitor of bacterial ribosomes, it is expected to have lower toxicity towards eukaryotic cells, whose ribosomes are structurally different. However, off-target effects cannot be ruled out without experimental validation. It is crucial to perform cytotoxicity assays (e.g., MTT, MTS, or CellTiter-Glo) to determine the tolerated concentration range in your specific cell line before proceeding with any functional assays.

Q4: How should I prepare and store **A201A**?

A201A is soluble in organic solvents such as dimethyl sulfoxide (DMSO) and ethanol. For in vitro experiments, it is advisable to prepare a high-concentration stock solution in a suitable solvent and then dilute it to the final working concentration in the culture medium. Stock solutions should be stored at -20°C or -80°C to maintain stability. Avoid repeated freeze-thaw cycles.

Troubleshooting Guide

Issue	Possible Cause	Recommended Solution
No antibacterial effect observed	1. Incorrect concentration of A201A. 2. Bacterial strain is resistant. 3. A201A has degraded.	1. Perform a dose-response experiment to determine the MIC. 2. Include a known sensitive bacterial strain as a positive control. 3. Prepare fresh A201A stock solutions.
High variability in results	1. Inconsistent bacterial inoculum size. 2. Pipetting errors. 3. Edge effects in multi-well plates.	1. Standardize the bacterial suspension to a specific optical density (e.g., 0.5 McFarland standard). 2. Ensure proper mixing and use calibrated pipettes. 3. Avoid using the outer wells of the plate or fill them with sterile medium.
Unexpected cytotoxicity in eukaryotic cells	1. A201A has off-target effects. 2. Solvent toxicity.	1. Perform a thorough cytotoxicity assessment to establish a non-toxic working concentration range. 2. Ensure the final solvent concentration in the culture medium is low (typically $\leq 0.5\%$) and include a solvent-only control.

Data Presentation

Due to the limited availability of public data, a comprehensive table of IC₅₀ or MIC values across a wide range of cell lines or bacterial strains for **A201A** cannot be provided.

Researchers are encouraged to determine these values empirically for their specific systems.

For illustrative purposes, a hypothetical MIC data table is presented below.

Bacterial Species	Hypothetical MIC50 ($\mu\text{g/mL}$)	Hypothetical MIC90 ($\mu\text{g/mL}$)
Staphylococcus aureus	1.5	3.0
Streptococcus pneumoniae	0.8	1.6
Escherichia coli	>64	>64
Pseudomonas aeruginosa	>64	>64

Note: These values are for example purposes only and are not based on published experimental data.

Experimental Protocols

Protocol: Determination of Minimum Inhibitory Concentration (MIC) by Broth Microdilution

This protocol outlines a standard method for determining the MIC of **A201A** against a specific bacterial strain.

Materials:

- **A201A** stock solution (e.g., 1 mg/mL in DMSO)
- Sterile 96-well microtiter plates
- Cation-adjusted Mueller-Hinton Broth (CAMHB)
- Bacterial culture in logarithmic growth phase
- 0.5 McFarland turbidity standard
- Spectrophotometer
- Incubator

Procedure:

- Prepare Bacterial Inoculum:
 - From a fresh agar plate, pick several colonies and suspend them in sterile saline.
 - Adjust the turbidity of the bacterial suspension to match the 0.5 McFarland standard (approximately 1.5×10^8 CFU/mL).
 - Dilute the adjusted suspension 1:150 in CAMHB to achieve a final inoculum density of approximately 5×10^5 CFU/mL.
- Prepare **A201A** Dilutions:
 - Add 100 μ L of CAMHB to all wells of a 96-well plate.
 - Add an additional 100 μ L of the **A201A** stock solution (appropriately diluted from the main stock) to the first well of each row to be tested, resulting in a 2-fold dilution.
 - Perform a 2-fold serial dilution by transferring 100 μ L from the first well to the second, and so on, down the plate. Discard 100 μ L from the last well.
- Inoculation:
 - Add 100 μ L of the prepared bacterial inoculum to each well containing the **A201A** dilutions.
 - Include a positive control well (bacteria in CAMHB without **A201A**) and a negative control well (CAMHB only).
- Incubation:
 - Incubate the plate at 37°C for 18-24 hours.
- Determine MIC:
 - The MIC is the lowest concentration of **A201A** that completely inhibits visible bacterial growth. This can be assessed visually or by measuring the optical density at 600 nm.

Visualizations

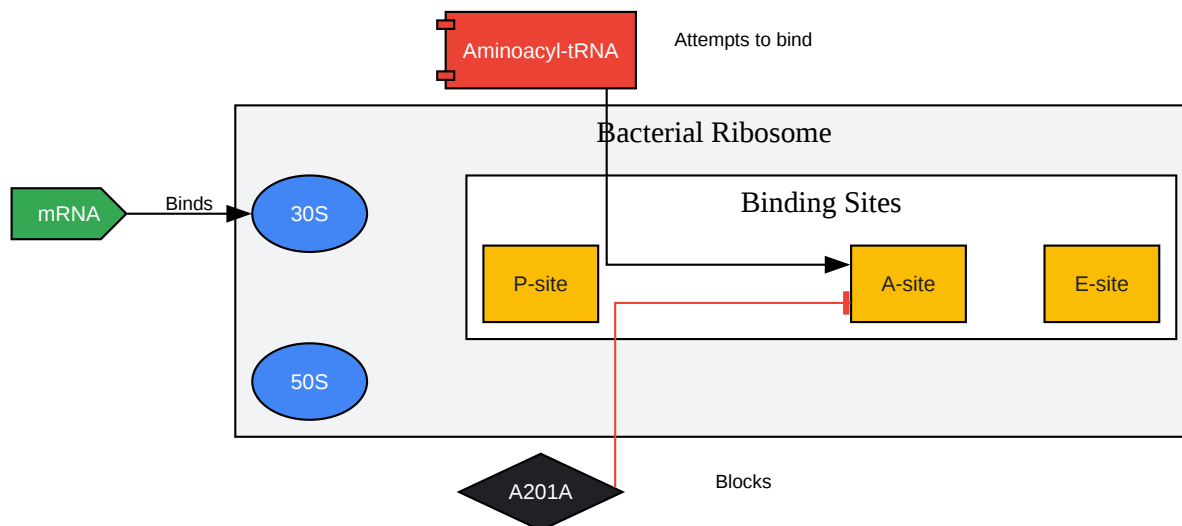

[Click to download full resolution via product page](#)

Caption: Mechanism of action of **A201A** in bacterial protein synthesis.

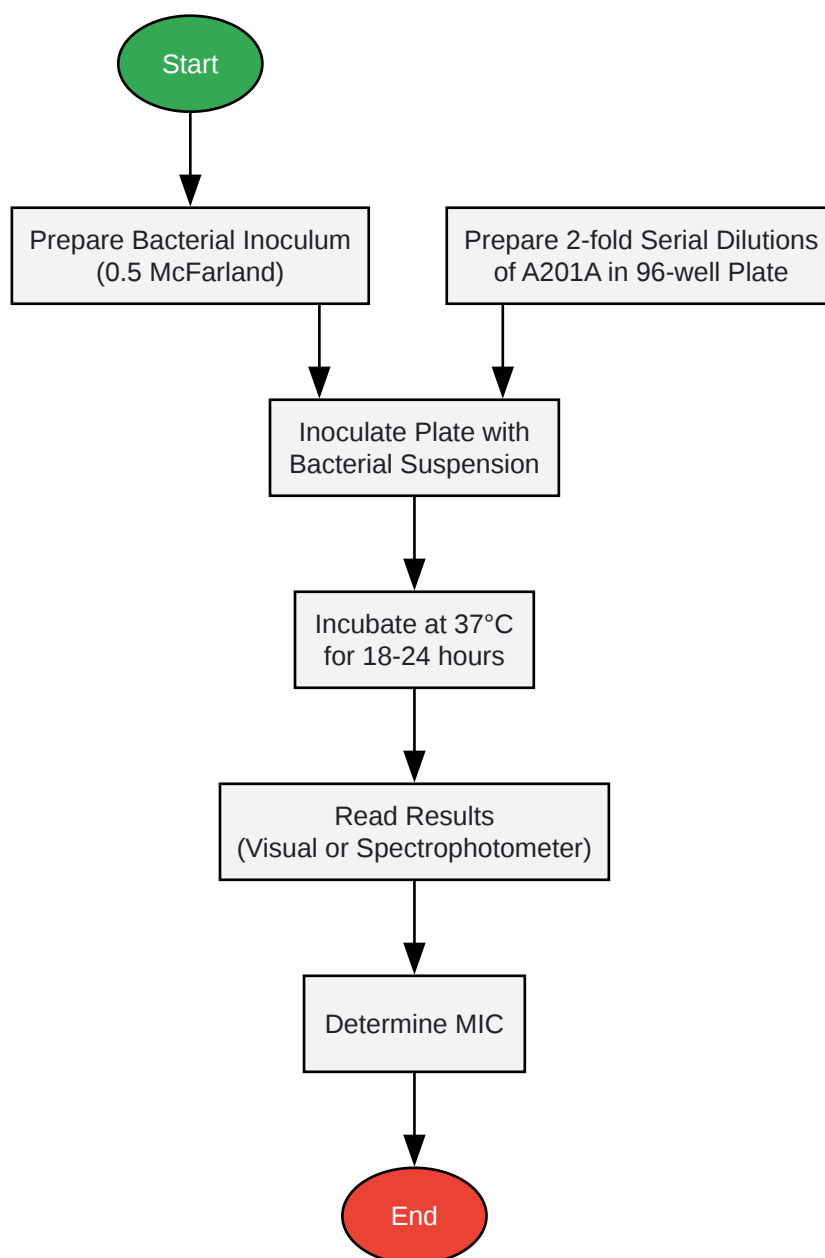

[Click to download full resolution via product page](#)

Caption: Experimental workflow for MIC determination.

Need Custom Synthesis?

BenchChem offers custom synthesis for rare earth carbides and specific isotopic labeling.

Email: info@benchchem.com or [Request Quote Online](#).

References

- [1. Discovery and engineered overproduction of antimicrobial nucleoside antibiotic A201A from the deep-sea marine actinomycete Marinactinospora thermotolerans SCSIO 00652 - PubMed \[pubmed.ncbi.nlm.nih.gov\]](#)
- [2. US3843784A - Antibiotics a201a and a201b and process for the production thereof - Google Patents \[patents.google.com\]](#)
- To cite this document: BenchChem. [Optimizing A201A concentration for in vitro experiments]. BenchChem, [2026]. [Online PDF]. Available at: [\[https://www.benchchem.com/product/b15565319/docs#optimizing-a201a-concentration-for-in-vitro-experiments\]](https://www.benchchem.com/product/b15565319/docs#optimizing-a201a-concentration-for-in-vitro-experiments)

Disclaimer & Data Validity:

The information provided in this document is for Research Use Only (RUO) and is strictly not intended for diagnostic or therapeutic procedures. While BenchChem strives to provide accurate protocols, we make no warranties, express or implied, regarding the fitness of this product for every specific experimental setup.

Technical Support: The protocols provided are for reference purposes. Unsure if this reagent suits your experiment?

Need Industrial/Bulk Grade? [Request Custom Synthesis Quote](#)

BenchChem

Our mission is to be the trusted global source of essential and advanced chemicals, empowering scientists and researchers to drive progress in science and industry.

Contact

Address: 3281 E Guasti Rd
Ontario, CA 91761, United States
Phone: (601) 213-4426
Email: info@benchchem.com

Contact our Ph.D. Support Team for a compatibility check