

Enhancing the antibacterial potency of Oxasetin through chemical modification

Author: BenchChem Technical Support Team. **Date:** April 2026

Compound of Interest

Compound Name: Oxasetin
Cat. No.: B15565317

[Get Quote](#)

Technical Support Center: Enhancing the Antibacterial Potency of Oxasetin

Disclaimer: **Oxasetin** is a fictional compound developed for illustrative purposes within this technical support center. The information provided is based on the well-established oxazolidinone class of antibiotics and is intended for research and development professionals.

This resource provides researchers, scientists, and drug development professionals with comprehensive troubleshooting guides, frequently asked questions (FAQs), and detailed protocols for the chemical modification and antibacterial potency testing of **Oxasetin**.

Frequently Asked Questions (FAQs) Chemical Modification & Synthesis

Q1: What are the primary strategies for modifying the **Oxasetin** core to enhance antibacterial potency?

A1: Key strategies focus on modifications at the C-5 side chain and the C-ring of the oxazolidinone scaffold.^{[1][2]} Introducing diverse heterocyclic groups, such as benzoxazinones,

at the C-ring can lead to superior activity compared to the parent compound.[2] Modifications to the C-5 side chain have also shown to increase activity against both susceptible and resistant Gram-positive bacteria.[1]

Q2: My synthetic yield for a novel **Oxasetin** analog is consistently low. What are the common pitfalls?

A2: Low yields in synthesizing oxazolidinone derivatives can stem from several factors. The integrity of the core β -lactam ring is critical, as it is susceptible to hydrolysis under acidic or basic conditions.[3] It is crucial to maintain a pH between 4.0 and 7.0 and use low temperatures.[3] Ensure all reactants are pure and dry, and run reactions under an inert atmosphere to prevent hydrolysis.[3]

Q3: What are the advantages of enzymatic synthesis for creating **Oxasetin** derivatives?

A3: Enzymatic synthesis offers a "green chemistry" approach, typically conducted in aqueous media under mild pH and ambient temperatures. This avoids hazardous reagents and the need for protecting groups on the core structure.[3]

Antibacterial Potency Testing

Q4: My Minimum Inhibitory Concentration (MIC) results for an **Oxasetin** analog are not reproducible. What could be the cause?

A4: Inconsistent MIC values can be due to several factors:

- **Inoculum Density:** The concentration of the bacterial culture significantly impacts MIC results. Ensure the inoculum is standardized, typically to a 0.5 McFarland turbidity standard.[4][5]
- **Media Composition:** Minor variations in media components can alter bacterial growth and the compound's activity.[5]
- **Compound Stability:** The analog may be degrading in the testing medium. Prepare fresh solutions for each experiment.
- **Subjective Endpoint Reading:** Visual determination of growth inhibition can be subjective. Consider using a microplate reader for a more quantitative endpoint.[6]

Q5: What is the "inoculum effect" and how can I minimize it?

A5: The inoculum effect is the observation that the MIC of an antimicrobial agent can increase with a higher bacterial inoculum density. To minimize this, strictly adhere to standardized inoculum preparation protocols, such as using a 0.5 McFarland standard.[4]

Troubleshooting Guides

Issue 1: Unexpectedly High MIC Values for a Promising Oxasetin Analog

Possible Cause	Observation	Recommended Action
Compound Degradation	Higher MIC values in older solutions compared to freshly prepared ones.	Prepare fresh stock solutions of the Oxasetin analog immediately before each experiment. Store stock solutions at recommended temperatures and protected from light.
Inaccurate Inoculum Density	Growth control wells are too turbid or not turbid enough.	Standardize the bacterial inoculum to a 0.5 McFarland standard using a calibrated photometric device or by visual comparison.[4]
Media Incompatibility	The analog may bind to components in the Mueller-Hinton Broth (MHB), reducing its effective concentration.	Test the solubility and stability of the compound in MHB. Consider using alternative broth media if incompatibility is suspected, but be aware this will deviate from standard protocols.
Resistance Development	MIC values increase with repeated exposure of the bacterial strain to the analog.	Sequence the genome of strains with increased MICs to identify potential mutations in target genes, such as the 23S rRNA.[7]

Issue 2: High Variability in Cytotoxicity Assay Results

Possible Cause	Observation	Recommended Action
Compound Interference	The Oxasetin analog has antioxidant properties that interfere with assays relying on cellular reduction (e.g., MTT, AlamarBlue).[8]	Run a "test compound control" with the analog in cell-free media to check for direct reduction of the assay reagent. [8] If interference is observed, use an alternative assay that measures a different endpoint, such as lactate dehydrogenase (LDH) release. [9]
Uneven Cell Seeding	Inconsistent cell numbers across wells of the microplate.	Ensure the cell suspension is homogenous before and during seeding. Use appropriate pipetting techniques to avoid introducing bubbles.
Solvent Toxicity	The vehicle used to dissolve the compound (e.g., DMSO) is causing cytotoxicity at the concentrations used.	Test the toxicity of the vehicle alone at all concentrations used in the experiment. Keep the final vehicle concentration consistent and as low as possible across all wells.

Data Presentation

Table 1: Hypothetical Antibacterial Potency of Modified Oxasetin Analogs

Compound	Modification	MIC ($\mu\text{g/mL}$) vs. <i>S. aureus</i> (MRSA)	MIC ($\mu\text{g/mL}$) vs. <i>E. faecium</i> (VRE)
Oxasetin (Parent)	-	4	8
OXA-001	C-Ring: Benzoxazinone	1	2
OXA-002	C-5 Side Chain: Thiocarbamate	2	4
OXA-003	C-Ring: Fused Pyrazole	0.5	1
Linezolid (Control)	-	2	2

Table 2: Hypothetical Cytotoxicity Data for Oxasetin Analogs

Compound	Cell Line	Assay	IC50 (μM)
Oxasetin (Parent)	HEK293	MTT	> 100
OXA-001	HEK293	MTT	85
OXA-002	HEK293	LDH	> 100
OXA-003	HEK293	MTT	92
Doxorubicin (Control)	HEK293	MTT	1.2

Experimental Protocols

Protocol 1: Broth Microdilution for Minimum Inhibitory Concentration (MIC) Determination[10][11]

- Preparation of Bacterial Inoculum:
 - Select three to five morphologically similar colonies of the test bacterium from an agar plate.

- Transfer the colonies to a tube with 5 mL of Mueller-Hinton Broth (MHB).
- Incubate at 37°C for 18-24 hours.
- Adjust the turbidity of the bacterial suspension to match a 0.5 McFarland standard (approximately $1-2 \times 10^8$ CFU/mL).
- Dilute this suspension in MHB to achieve a final concentration of approximately 5×10^5 CFU/mL.[10]
- Preparation of Microtiter Plate:
 - Use a 96-well microtiter plate.
 - Add 50 μ L of MHB to wells in columns 2-11.
 - Prepare a stock solution of the **Oxasetin** analog at twice the highest desired concentration.
 - Add 100 μ L of the analog stock solution to the wells in column 1.
 - Perform a two-fold serial dilution by transferring 50 μ L from column 1 to column 2, mixing, and repeating this process down to column 10. Discard the final 50 μ L from column 10.
 - Column 11 serves as the growth control (inoculum without the compound).
 - Column 12 serves as the sterility control (broth without inoculum).
- Inoculation and Incubation:
 - Add 50 μ L of the standardized bacterial inoculum to each well (columns 1-11).
 - Cover the plate and incubate at $35^\circ\text{C} \pm 2^\circ\text{C}$ for 16-20 hours.[4]
- Interpretation of Results:
 - After incubation, visually inspect the wells for turbidity. The MIC is the lowest concentration of the **Oxasetin** analog that completely inhibits visible bacterial growth.[10]

Protocol 2: MTT Assay for Cytotoxicity Assessment[13] [14]

- Cell Seeding:
 - Trypsinize and count the desired mammalian cell line (e.g., HEK293).
 - Seed the cells in a 96-well plate at a density of 5,000-10,000 cells/well in 100 μ L of complete culture medium.
 - Incubate the plate at 37°C in a humidified 5% CO₂ incubator for 24 hours.
- Compound Treatment:
 - Prepare a series of dilutions of the **Oxasetin** analog in complete culture medium.
 - Remove the old medium from the cells and add the medium containing the different concentrations of the analog.
 - Include a vehicle control (medium with the same concentration of solvent, e.g., DMSO) and a no-cell control (medium only).
 - Incubate for the desired exposure time (e.g., 24, 48, or 72 hours).
- MTT Addition and Incubation:
 - Add 10 μ L of a 5 mg/mL MTT solution to each well.
 - Incubate the plate for 2-4 hours at 37°C.
- Formazan Solubilization and Measurement:
 - Carefully remove the medium from the wells.
 - Add 100 μ L of an MTT solvent (e.g., isopropanol with 0.01 M HCl) to each well to dissolve the formazan crystals.
 - Mix gently on an orbital shaker for 15 minutes.

- o Measure the absorbance at a wavelength of 590 nm using a microplate reader.

Visualizations

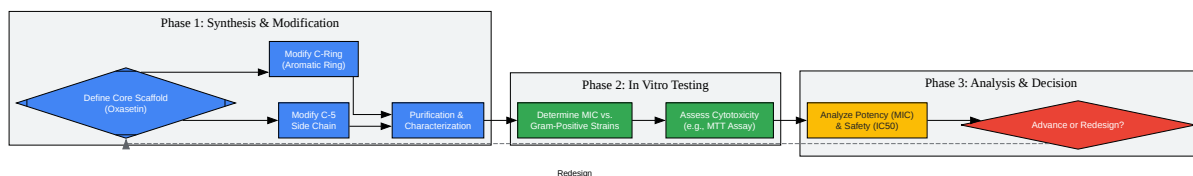

[Click to download full resolution via product page](#)

Caption: Workflow for chemical modification and evaluation of **Oxasetin** analogs.

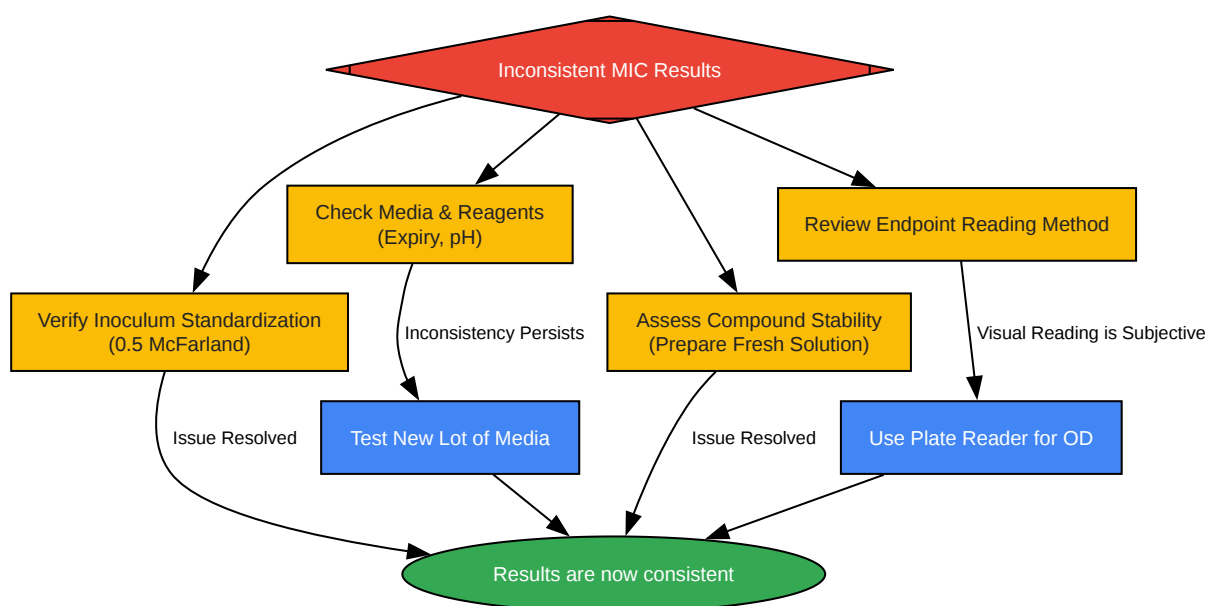

[Click to download full resolution via product page](#)

Caption: Troubleshooting guide for inconsistent MIC (Minimum Inhibitory Concentration) results.

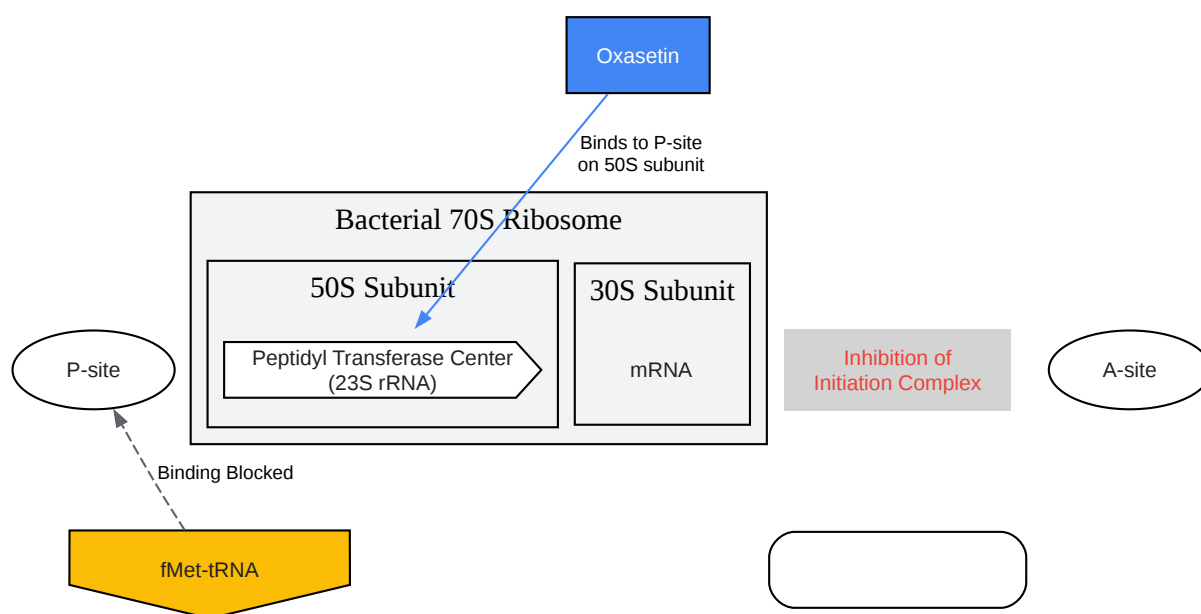

[Click to download full resolution via product page](#)

Caption: Mechanism of action for **Oxasetin**, an oxazolidinone antibiotic.[7][11][12]

Need Custom Synthesis?

BenchChem offers custom synthesis for rare earth carbides and specific isotopic labeling.

Email: info@benchchem.com or [Request Quote Online](#).

References

- 1. Oxazolidinones as versatile scaffolds in medicinal chemistry - PMC [[pmc.ncbi.nlm.nih.gov](https://pubmed.ncbi.nlm.nih.gov/)]
- 2. Design, Synthesis, and Antibacterial Evaluation of Oxazolidinones with Fused Heterocyclic C-Ring Substructure - PMC [[pmc.ncbi.nlm.nih.gov](https://pubmed.ncbi.nlm.nih.gov/)]

- [3. benchchem.com \[benchchem.com\]](#)
- [4. benchchem.com \[benchchem.com\]](#)
- [5. benchchem.com \[benchchem.com\]](#)
- [6. benchchem.com \[benchchem.com\]](#)
- [7. Mechanism of action of the oxazolidinone antibacterial agents - PubMed \[pubmed.ncbi.nlm.nih.gov\]](#)
- [8. assets-eu.researchsquare.com \[assets-eu.researchsquare.com\]](#)
- [9. Cytotoxicity Assays: In Vitro Methods to Measure Dead Cells - Assay Guidance Manual - NCBI Bookshelf \[ncbi.nlm.nih.gov\]](#)
- [10. microbe-investigations.com \[microbe-investigations.com\]](#)
- [11. researchgate.net \[researchgate.net\]](#)
- [12. Oxazolidinones mechanism of action: inhibition of the first peptide bond formation - PubMed \[pubmed.ncbi.nlm.nih.gov\]](#)
- To cite this document: BenchChem. [Enhancing the antibacterial potency of Oxasetin through chemical modification]. BenchChem, [2026]. [Online PDF]. Available at: [<https://www.benchchem.com/product/b15565317/docs#enhancing-the-antibacterial-potency-of-oxasetin-through-chemical-modification>]

Disclaimer & Data Validity:

The information provided in this document is for Research Use Only (RUO) and is strictly not intended for diagnostic or therapeutic procedures. While BenchChem strives to provide accurate protocols, we make no warranties, express or implied, regarding the fitness of this product for every specific experimental setup.

Technical Support: The protocols provided are for reference purposes. Unsure if this reagent suits your experiment?

Need Industrial/Bulk Grade? [Request Custom Synthesis Quote](#)

BenchChem

Our mission is to be the trusted global source of essential and advanced chemicals, empowering scientists and researchers to drive progress in science and industry.

Contact

Address: 3281 E Guasti Rd

Ontario, CA 91761, United States

Phone: (601) 213-4426

Email: info@benchchem.com

[Contact our Ph.D. Support Team for a compatibility check](#)