

Determining the Absolute Stereochemistry of Axinysonone B: A Methodological Guide

Author: BenchChem Technical Support Team. **Date:** April 2026

Compound of Interest

Compound Name: Axinysonone B

Cat. No.: B15565282

[Get Quote](#)

For Researchers, Scientists, and Drug Development Professionals

The precise three-dimensional arrangement of atoms in a molecule, its absolute stereochemistry, is a critical determinant of its biological activity. For novel natural products such as **Axinysonone B**, unambiguously assigning the absolute configuration of all stereogenic centers is a foundational step in understanding its therapeutic potential and developing synthetic routes for its production. This technical guide outlines the common, powerful techniques employed to elucidate the absolute stereochemistry of complex molecules, using the hypothetical case of **Axinysonone B** as an illustrative framework.

Due to the limited publicly available information specifically detailing the stereochemical determination of **Axinysonone B**, this document serves as a comprehensive overview of the established methodologies that would be applied to a molecule of its nature. The primary methods discussed include Nuclear Magnetic Resonance (NMR) spectroscopy, chiroptical methods such as Electronic Circular Dichroism (ECD), and computational analysis.

Spectroscopic and Chiroptical Analysis

A cornerstone in the determination of absolute stereochemistry is the use of spectroscopic techniques that are sensitive to the chiral nature of a molecule. These methods provide data

that can be compared with computationally predicted values for different stereoisomers to identify the correct configuration.

The Mosher method is a well-established NMR technique used to determine the absolute configuration of chiral secondary alcohols and amines.[1][2] This method involves the derivatization of the chiral substrate with enantiomerically pure α -methoxy- α -trifluoromethylphenylacetic acid (MTPA), also known as Mosher's acid, to form diastereomeric esters or amides.[1][2] The anisotropic effect of the phenyl ring in the MTPA derivatives causes measurable differences in the chemical shifts ($\Delta\delta$) of protons near the chiral center for the two diastereomers.

Table 1: Hypothetical ^1H NMR Chemical Shift Differences ($\Delta\delta = \delta\text{S} - \delta\text{R}$) for MTPA Esters of an **Axinyson B** Fragment

Proton	δ for (R)-MTPA Ester (ppm)	δ for (S)-MTPA Ester (ppm)	$\Delta\delta$ ($\delta\text{S} - \delta\text{R}$) (ppm)
H-2'	4.85	4.95	+0.10
H-3'a	2.10	2.02	-0.08
H-3'b	2.25	2.15	-0.10
OMe	3.40	3.35	-0.05

Note: This data is illustrative for a hypothetical fragment of **Axinyson B** containing a secondary alcohol.

A consistent sign for the $\Delta\delta$ values on one side of the MTPA plane versus the other allows for the assignment of the absolute configuration.[1]

Electronic Circular Dichroism (ECD) spectroscopy measures the differential absorption of left and right circularly polarized light by a chiral molecule.[3] The resulting spectrum, with its characteristic positive and negative Cotton effects, is highly sensitive to the absolute configuration of the molecule.[3] The modern approach involves comparing the experimentally measured ECD spectrum with the spectra predicted for all possible stereoisomers using time-dependent density functional theory (TD-DFT) calculations.[3]

Table 2: Comparison of Experimental and Calculated ECD Data for a Hypothetical **Axinysonone B** Isomer

Stereoisomer	Calculated λ_{\max} (nm)	Calculated $\Delta\epsilon$	Experimental λ_{\max} (nm)	Experimental $\Delta\epsilon$
(1R, 5S)- Axinysonone B	215	+12.5	218	+10.2
	240	-8.2	242	-7.5
	280	+5.1	283	+4.8
(1S, 5R)- Axinysonone B	215	-12.3		
	240	+8.1		
	280	-5.0		

A good agreement between the experimental and a calculated spectrum allows for the unambiguous assignment of the absolute stereochemistry.

Experimental Protocols

Detailed and rigorous experimental procedures are paramount for obtaining high-quality data for stereochemical analysis.

- Preparation of (R)-MTPA and (S)-MTPA Esters:
 - To a solution of the **Axinysonone B** fragment (1.0 mg, 1 equiv) in dry pyridine (0.5 mL) is added (R)-MTPA-Cl (1.2 equiv) at room temperature under an argon atmosphere.
 - The reaction mixture is stirred for 12 hours.
 - The solvent is removed under reduced pressure, and the residue is purified by HPLC to yield the (R)-MTPA ester.
 - The same procedure is followed using (S)-MTPA-Cl to synthesize the (S)-MTPA ester.

- NMR Data Acquisition:
 - The ^1H NMR spectra for both diastereomeric esters are recorded on a high-field NMR spectrometer (e.g., 600 MHz) in CDCl_3 .
 - The chemical shifts of protons adjacent to the newly formed ester linkage are carefully assigned using 2D NMR techniques (e.g., COSY, HSQC).
 - The chemical shift differences ($\Delta\delta = \delta_S - \delta_R$) are calculated for all assigned protons.
- ECD Spectrum Measurement:
 - A solution of **Axinysonone B** is prepared in a suitable solvent (e.g., methanol) at a concentration of approximately 0.1 mg/mL.
 - The ECD spectrum is recorded on a chiroptical spectrometer over a wavelength range of 200-400 nm.
- Computational Modeling:
 - A conformational search for all possible stereoisomers of **Axinysonone B** is performed using a molecular mechanics force field.
 - The geometries of the low-energy conformers are optimized using density functional theory (DFT) at a suitable level of theory (e.g., B3LYP/6-31G(d)).
 - The ECD spectra for each optimized conformer are calculated using time-dependent DFT (TD-DFT).
 - The final calculated ECD spectrum for each stereoisomer is obtained by Boltzmann averaging the spectra of the individual conformers.
- Comparison and Assignment:
 - The experimental ECD spectrum is compared with the Boltzmann-averaged calculated spectra of all possible stereoisomers.

- The absolute configuration is assigned based on the best match between the experimental and a calculated spectrum.

Visualization of Workflows

Graphical representations of the experimental and logical workflows can aid in understanding the process of absolute stereochemistry determination.

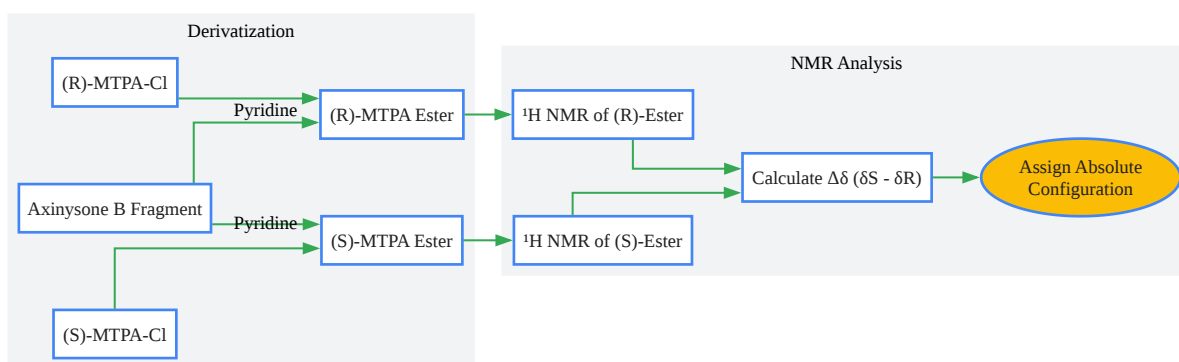

[Click to download full resolution via product page](#)

Caption: Workflow for the Mosher Method.

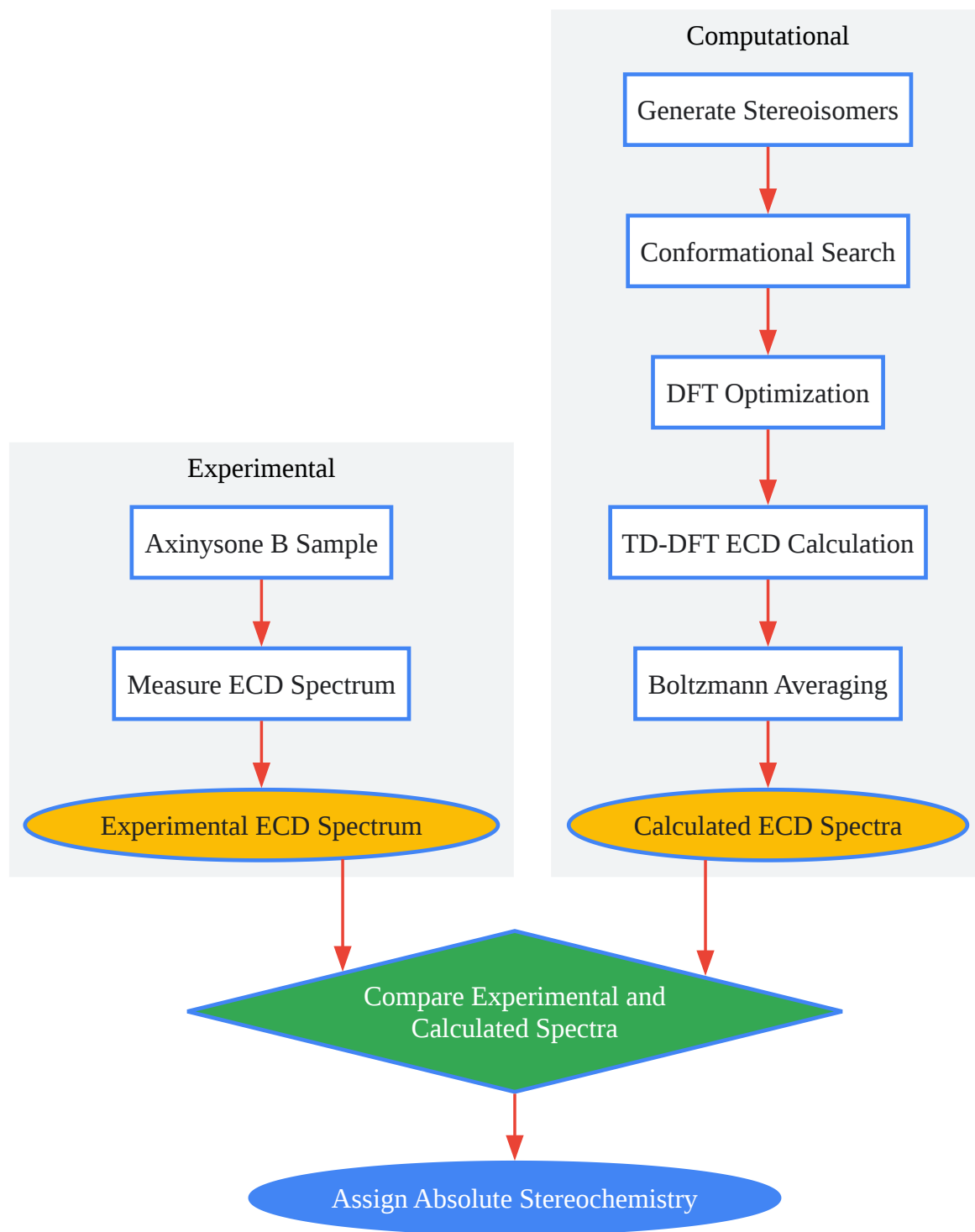

[Click to download full resolution via product page](#)

Caption: Workflow for ECD Analysis.

Conclusion

The determination of the absolute stereochemistry of a novel natural product like **Axinyson B** is a multifaceted process that relies on the synergistic application of modern spectroscopic and computational techniques. While total synthesis remains the ultimate proof of a structural assignment, the methods outlined in this guide, particularly the combination of Mosher's method and ECD analysis with computational modeling, provide a powerful and reliable means of elucidating the complete three-dimensional structure of complex chiral molecules. This foundational knowledge is indispensable for the advancement of drug discovery and development programs.

Need Custom Synthesis?

BenchChem offers custom synthesis for rare earth carbides and specific isotopic labeling.

Email: info@benchchem.com or [Request Quote Online](#).

References

- [1. Isolation and structure elucidation of new and unusual saxitoxin analogues from mussels - PubMed \[pubmed.ncbi.nlm.nih.gov\]](#)
- [2. Isolation and structural elucidation of new cyclotrapeptides, trapoxins A and B, having detransformation activities as antitumor agents - PubMed \[pubmed.ncbi.nlm.nih.gov\]](#)
- [3. par.nsf.gov \[par.nsf.gov\]](#)
- To cite this document: BenchChem. [Determining the Absolute Stereochemistry of Axinyson B: A Methodological Guide]. BenchChem, [2026]. [Online PDF]. Available at: [\[https://www.benchchem.com/product/b15565282/docs#determining-the-absolute-stereochemistry-of-axinyson-b-a-methodological-guide\]](https://www.benchchem.com/product/b15565282/docs#determining-the-absolute-stereochemistry-of-axinyson-b-a-methodological-guide)

Disclaimer & Data Validity:

The information provided in this document is for Research Use Only (RUO) and is strictly not intended for diagnostic or therapeutic procedures. While BenchChem strives to provide accurate protocols, we make no warranties, express or implied, regarding the fitness of this product for every specific experimental setup.

Technical Support: The protocols provided are for reference purposes. Unsure if this reagent suits your experiment?

Need Industrial/Bulk Grade? [Request Custom Synthesis Quote](#)

BenchChem

Our mission is to be the trusted global source of essential and advanced chemicals, empowering scientists and researchers to drive progress in science and industry.

Contact

Address: 3281 E Guasti Rd
Ontario, CA 91761, United States
Phone: (601) 213-4426
Email: info@benchchem.com

[Contact our Ph.D. Support Team for a compatibility check](#)