

Audience: Researchers, Scientists, and Drug Development Professionals

Author: BenchChem Technical Support Team. **Date:** April 2026

Compound of Interest

Compound Name:	GGACK
CAS No.:	65113-67-9
Cat. No.:	B1608369

[Get Quote](#)

Abstract

L-glutamyl-glycyl-L-arginyl-chloromethylketone (**GGACK**) is a synthetic, irreversible inhibitor of serine proteases, which plays a significant role as an anticoagulant by targeting key enzymes within the coagulation cascade. This technical guide elucidates the mechanism of action of **GGACK**, presents quantitative data on its inhibitory potency, provides detailed experimental protocols for its characterization, and visually represents its interaction with the coagulation pathways. The information herein is intended to serve as a comprehensive resource for professionals engaged in hemostasis research and the development of novel anticoagulant therapies.

The Coagulation Cascade: An Overview

The coagulation cascade is a sophisticated biological process that culminates in the formation of a fibrin clot to prevent blood loss following vascular injury.^{[1][2][3]} It is traditionally divided into two primary pathways that converge into a final common pathway.

- The Extrinsic Pathway: Initiated by the exposure of Tissue Factor (TF) at the site of injury, which complexes with Factor VIIa (FVIIa) to activate Factor X (FX).^{[1][4]} This pathway is

responsible for the initial "thrombin burst".^[1]

- The Intrinsic Pathway: Activated when blood comes into contact with a negatively charged surface, leading to a cascade of factor activations (FXII, FXI, FIX) that ultimately also activates FX.^{[1][5]}
- The Common Pathway: Begins with the activation of Factor X to Factor Xa (FXa). FXa, along with its cofactor Factor Va (FVa), forms the prothrombinase complex which converts prothrombin (Factor II) into thrombin (Factor IIa).^[4] Thrombin then cleaves fibrinogen into fibrin, which is cross-linked by Factor XIIIa to form a stable clot.^{[1][6]}

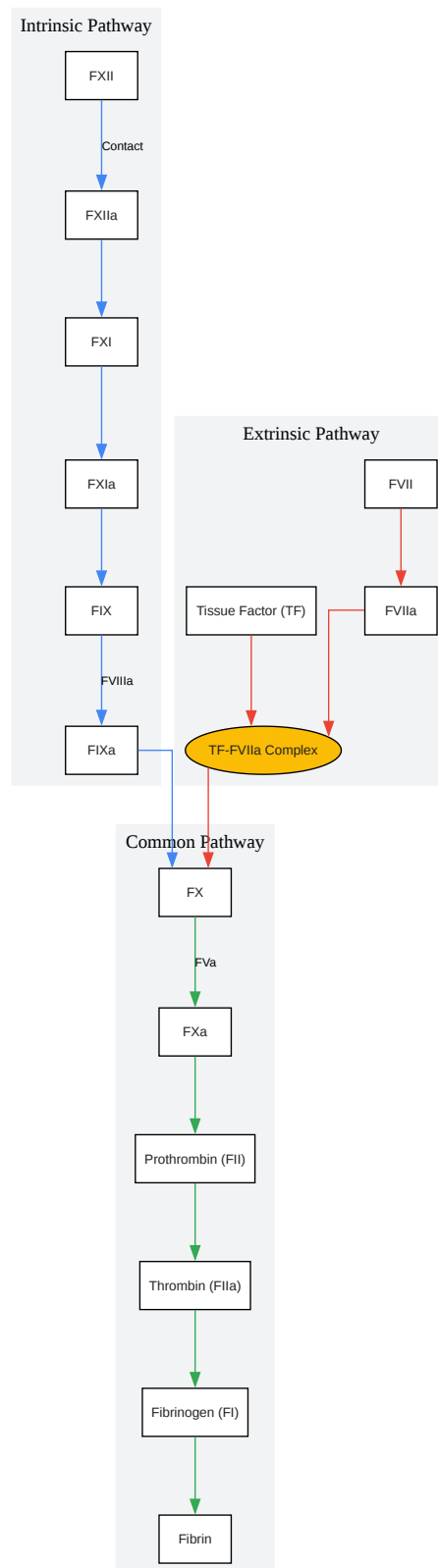

[Click to download full resolution via product page](#)

Caption: The intrinsic, extrinsic, and common pathways of the coagulation cascade.

GGACK: Mechanism of Action

GGACK (H-Glu-Gly-Arg-chloromethylketone) is a potent, irreversible inhibitor that targets serine proteases.[7] Its tripeptide sequence (Glutamyl-Glycyl-Arginine) mimics the substrate recognition site of key coagulation factors, granting it specificity. The chloromethylketone reactive group covalently binds to the active site histidine residue of the target enzyme, leading to its permanent inactivation.[8]

The primary targets of **GGACK** within the coagulation cascade are:

- Factor Xa (FXa): The enzyme at the convergence of the intrinsic and extrinsic pathways.[7]
- Thrombin (Factor IIa): The final effector protease of the cascade.

By irreversibly inhibiting these critical enzymes, **GGACK** effectively halts the amplification of the coagulation signal and prevents the conversion of fibrinogen to fibrin, thereby exhibiting its anticoagulant effect. A dansylated version of **GGACK** has also been shown to be a potent in vitro anticoagulant by irreversibly inhibiting Factor IXa.[8]

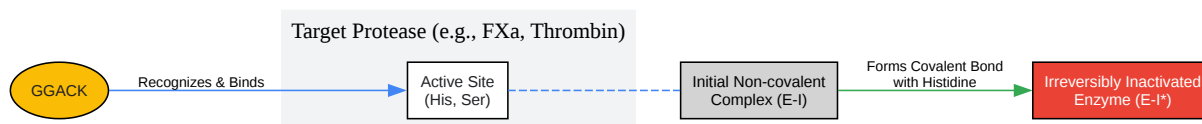

[Click to download full resolution via product page](#)

Caption: **GGACK** irreversibly inactivates target serine proteases via covalent modification.

Quantitative Data: Inhibitory Potency of GGACK Derivatives

The efficacy of an irreversible inhibitor is often quantified by the apparent second-order rate constant. The data below is for Dansyl-Glu-Gly-Arg-chloromethylketone (DEGR-CK), a derivative of **GGACK**, against a key coagulation factor.

Target Enzyme	Species	Apparent Second-Order Rate Constant ($M^{-1} \text{ min}^{-1}$)	Stoichiometry (Inhibitor:Enzyme)	Reference
Factor IXa	Porcine	1.7×10^4	1.2 : 1	[8]

Note: This data is for a dansylated derivative of **GGACK**. Potency can vary based on the specific target enzyme, species, and experimental conditions.

Key Experimental Protocols

Assessing the anticoagulant activity of an inhibitor like **GGACK** involves both enzymatic and plasma-based assays.

In Vitro Enzyme Inhibition Kinetics

Objective: To determine the rate of inactivation of a target protease (e.g., Factor Xa) by **GGACK**.

Methodology:

- Reagents & Materials: Purified Factor Xa, **GGACK** stock solution, chromogenic FXa substrate (e.g., S-2222), assay buffer (e.g., Tris-HCl, pH 7.5, with NaCl and CaCl_2), 96-well microplate, and a microplate reader.
- Procedure: a. A fixed concentration of Factor Xa is incubated with various concentrations of **GGACK** in the assay buffer at 37°C. b. At specific time intervals, aliquots are removed and added to a 96-well plate containing the chromogenic substrate. c. The residual active Factor Xa cleaves the substrate, producing a colorimetric signal that is measured at 405 nm. d. The rate of color development is proportional to the remaining enzyme activity.
- Data Analysis: a. The natural logarithm of the residual enzyme activity is plotted against incubation time. The negative slope of this plot yields the apparent first-order rate constant (k_{obs}) for each **GGACK** concentration. b. The values of k_{obs} are then plotted against the corresponding **GGACK** concentrations. The slope of this secondary plot represents the apparent second-order rate constant of inhibition.

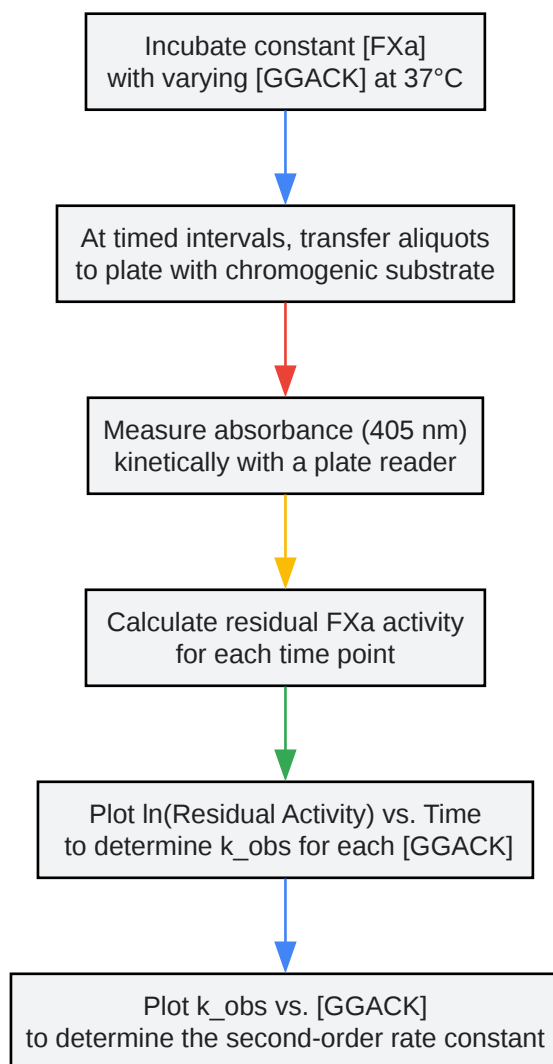

[Click to download full resolution via product page](#)

Need Custom Synthesis?

BenchChem offers custom synthesis for rare earth carbides and specific isotopic labeling.

Email: info@benchchem.com or [Request Quote Online](#).

References

- 1. [Coagulation - Wikipedia \[en.wikipedia.org\]](#)
- 2. [rroj.com \[rroj.com\]](#)

- [3. Mechanism Action of Platelets and Crucial Blood Coagulation Pathways in Hemostasis - PMC \[pmc.ncbi.nlm.nih.gov\]](#)
- [4. The Clotting Cascade | National Bleeding Disorders Foundation \[bleeding.org\]](#)
- [5. Back to basics: the coagulation pathway \[bloodresearch.or.kr\]](#)
- [6. The Coagulation Cascade | Mackman Lab \[med.unc.edu\]](#)
- [7. 错误页 \[amp.chemicalbook.com\]](#)
- [8. Inhibition of activated porcine factor IX by dansyl-glutamyl-glycyl-arginyl-chloromethylketone - PubMed \[pubmed.ncbi.nlm.nih.gov\]](#)
- [To cite this document: BenchChem. \[Audience: Researchers, Scientists, and Drug Development Professionals\]. BenchChem, \[2026\]. \[Online PDF\]. Available at: \[https://www.benchchem.com/product/b1608369/docs#audience-researchers-scientists-and-drug-development-professionals\]](#)

Disclaimer & Data Validity:

The information provided in this document is for Research Use Only (RUO) and is strictly not intended for diagnostic or therapeutic procedures. While BenchChem strives to provide accurate protocols, we make no warranties, express or implied, regarding the fitness of this product for every specific experimental setup.

Technical Support: The protocols provided are for reference purposes. Unsure if this reagent suits your experiment?

Need Industrial/Bulk Grade? [Request Custom Synthesis Quote](#)

BenchChem

Our mission is to be the trusted global source of essential and advanced chemicals, empowering scientists and researchers to drive progress in science and industry.

Contact

Address: 3281 E Guasti Rd
Ontario, CA 91761, United States
Phone: (601) 213-4426
Email: info@benchchem.com

Contact our Ph.D. Support Team for a compatibility check