

Application Notes and Protocols for In Vitro Antibacterial Assays of Novel Compounds

Author: BenchChem Technical Support Team. **Date:** April 2026

Compound of Interest

Compound Name: *Elmycin D*
Cat. No.: *B15565326*

[Get Quote](#)

For Researchers, Scientists, and Drug Development Professionals

Abstract

This document provides a comprehensive set of protocols for the in vitro evaluation of the antibacterial activity of a novel compound, exemplified here as **Elmycin D**. Due to the limited publicly available information on "Elmycin D" as an antibacterial agent, with some references pointing to an antifungal with a similar name, these protocols are presented as a general guide for the initial screening and characterization of any new potential antibacterial agent. The methodologies detailed include the determination of Minimum Inhibitory Concentration (MIC), Minimum Bactericidal Concentration (MBC), and the analysis of bacterial growth kinetics in the presence of the test compound.

Introduction

The rise of antibiotic-resistant bacteria necessitates the discovery and development of new antimicrobial agents. A critical early step in this process is the in vitro characterization of a compound's antibacterial properties. This involves determining the lowest concentration of the agent that inhibits bacterial growth (MIC) and the lowest concentration that kills the bacteria (MBC). Furthermore, understanding the effect of the compound on bacterial growth over time

provides valuable insights into its mechanism of action, such as whether it is bacteriostatic (inhibits growth) or bactericidal (kills bacteria).

This application note outlines the standardized procedures for conducting these fundamental assays, ensuring reproducible and comparable results.

Key Experimental Protocols

Minimum Inhibitory Concentration (MIC) Assay

The MIC is the lowest concentration of an antimicrobial agent that prevents the visible in vitro growth of a microorganism.[1][2] The broth microdilution method is a widely used and accurate technique for determining MIC values.[3]

Protocol: Broth Microdilution Assay

- Preparation of Reagents and Materials:
 - Test compound (e.g., **Elmycin D**) stock solution of known concentration.
 - Bacterial strains for testing (e.g., *Staphylococcus aureus*, *Escherichia coli*).
 - Cation-adjusted Mueller-Hinton Broth (CAMHB).
 - Sterile 96-well microtiter plates.
 - Spectrophotometer.
- Inoculum Preparation:
 - From a fresh agar plate (18-24 hours growth), pick a single, well-isolated colony of the test bacterium.
 - Inoculate the colony into a tube containing 3-5 mL of CAMHB.
 - Incubate at 37°C with agitation until the turbidity reaches that of a 0.5 McFarland standard (approximately 1.5×10^8 CFU/mL).

- Dilute the standardized inoculum in CAMHB to achieve a final concentration of approximately 5×10^5 CFU/mL in the assay wells.[2]
- Assay Plate Preparation:
 - Prepare a two-fold serial dilution of the test compound in the 96-well plate.
 - Add 100 μ L of sterile CAMHB to wells in columns 2 through 12.
 - Add 200 μ L of the test compound stock solution (at twice the highest desired final concentration) to the wells in column 1.[1]
 - Perform a serial dilution by transferring 100 μ L from column 1 to column 2, mixing, then transferring 100 μ L from column 2 to column 3, and so on, up to column 10. Discard 100 μ L from column 10.
 - Column 11 serves as the growth control (no compound), and column 12 serves as the sterility control (no bacteria).
- Inoculation and Incubation:
 - Add 100 μ L of the diluted bacterial inoculum to each well from columns 1 to 11. The final volume in each well will be 200 μ L.
 - Cover the plate and incubate at 37°C for 16-20 hours.
- Reading and Interpreting Results:
 - After incubation, visually inspect the plate for turbidity. The MIC is the lowest concentration of the compound at which there is no visible bacterial growth.

Minimum Bactericidal Concentration (MBC) Assay

The MBC is the lowest concentration of an antimicrobial agent required to kill a particular bacterium. It is determined after the MIC assay by subculturing from wells that show no visible growth.

Protocol: MBC Determination

- Subculturing:
 - Following the MIC determination, select the wells corresponding to the MIC and at least two higher concentrations that showed no visible growth.
 - From each of these selected wells, aspirate 10-100 μ L of the broth.
 - Spread the aspirated volume onto a sterile agar plate (e.g., Mueller-Hinton Agar).
- Incubation:
 - Incubate the agar plates at 37°C for 18-24 hours.
- Reading and Interpreting Results:
 - After incubation, count the number of colonies on each plate.
 - The MBC is the lowest concentration of the test compound that results in a $\geq 99.9\%$ reduction in the initial inoculum count.

Data Presentation

Quantitative data from the MIC and MBC assays should be summarized in a clear and structured table for easy comparison.

Table 1: In Vitro Antibacterial Activity of **Elmycin D**

Bacterial Strain	ATCC Number	MIC ($\mu\text{g/mL}$)	MBC ($\mu\text{g/mL}$)	Interpretation (MBC/MIC Ratio)
Staphylococcus aureus	29213	4	8	Bactericidal (≤ 4)
Escherichia coli	25922	16	>64	Bacteriostatic (>4)
Pseudomonas aeruginosa	27853	32	>64	Bacteriostatic (>4)
Enterococcus faecalis	29212	8	16	Bactericidal (≤ 4)

Note: The data presented in this table is hypothetical and for illustrative purposes only.

Visualization of Experimental Workflow

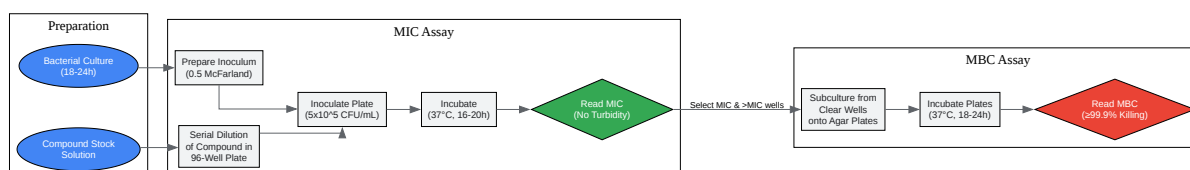

[Click to download full resolution via product page](#)

Caption: Workflow for determining MIC and MBC of a test compound.

Additional Protocols: Bacterial Growth Curve Analysis

To further characterize the antibacterial effect, a growth curve analysis (time-kill assay) can be performed. This assay monitors the rate of bacterial killing over time at different concentrations of the compound.

Protocol: Time-Kill Kinetic Assay

- Preparation:
 - Prepare flasks containing CAMHB with the test compound at various concentrations (e.g., 0.5x MIC, 1x MIC, 2x MIC, 4x MIC). Include a growth control flask without the compound.
 - Prepare a bacterial inoculum as described for the MIC assay, but adjust the final concentration in the flasks to approximately 5×10^5 CFU/mL.
- Incubation and Sampling:
 - Incubate the flasks at 37°C with agitation.
 - At specified time points (e.g., 0, 2, 4, 6, 8, 24 hours), aseptically remove an aliquot from each flask.
- Viable Cell Counting:
 - Perform serial dilutions of each aliquot in sterile saline or PBS.
 - Plate the dilutions onto agar plates and incubate for 18-24 hours.
 - Count the colonies on the plates to determine the number of viable bacteria (CFU/mL) at each time point.
- Data Analysis:
 - Plot the \log_{10} CFU/mL versus time for each concentration.
 - A bactericidal effect is typically defined as a ≥ 3 - \log_{10} (99.9%) reduction in CFU/mL from the initial inoculum. A bacteriostatic effect is observed when there is a prevention of growth but not a significant reduction in the viable count.

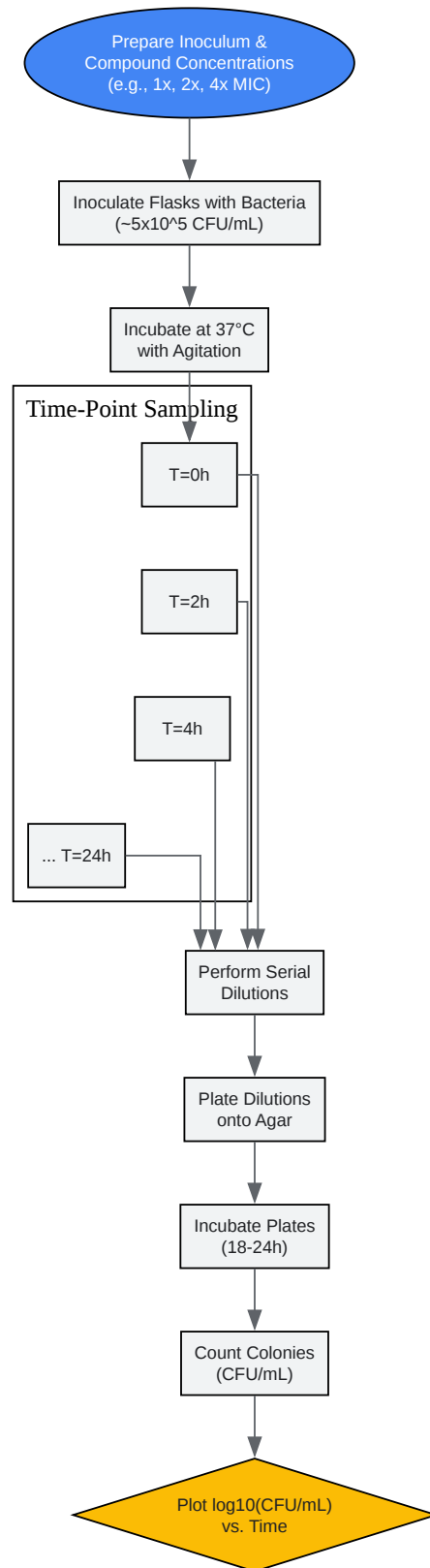

[Click to download full resolution via product page](#)

Caption: Workflow for a time-kill kinetic assay.

Conclusion

The protocols detailed in this application note provide a robust framework for the initial in vitro assessment of a novel antibacterial compound. Accurate determination of MIC, MBC, and time-kill kinetics are essential for characterizing the compound's potency and spectrum of activity, guiding further preclinical development.

Need Custom Synthesis?

BenchChem offers custom synthesis for rare earth carbides and specific isotopic labeling.

Email: info@benchchem.com or [Request Quote Online](#).

References

- [1. benchchem.com](https://www.benchchem.com) [benchchem.com]
- [2. Broth Dilution Method for MIC Determination • Microbe Online](#) [microbeonline.com]
- [3. Broth microdilution - Wikipedia](#) [en.wikipedia.org]
- To cite this document: BenchChem. [Application Notes and Protocols for In Vitro Antibacterial Assays of Novel Compounds]. BenchChem, [2026]. [Online PDF]. Available at: [\[https://www.benchchem.com/product/b15565326/docs#application-notes-and-protocols-for-in-vitro-antibacterial-assays-of-novel-compounds\]](https://www.benchchem.com/product/b15565326/docs#application-notes-and-protocols-for-in-vitro-antibacterial-assays-of-novel-compounds)

Disclaimer & Data Validity:

The information provided in this document is for Research Use Only (RUO) and is strictly not intended for diagnostic or therapeutic procedures. While BenchChem strives to provide accurate protocols, we make no warranties, express or implied, regarding the fitness of this product for every specific experimental setup.

Technical Support: The protocols provided are for reference purposes. Unsure if this reagent suits your experiment?

Need Industrial/Bulk Grade? [Request Custom Synthesis Quote](#)

BenchChem

Our mission is to be the trusted global source of essential and advanced chemicals, empowering scientists and researchers to drive progress in science and industry.

Contact

Address: 3281 E Guasti Rd

Ontario, CA 91761, United States

Phone: (601) 213-4426

Email: info@benchchem.com

[Contact our Ph.D. Support Team for a compatibility check](#)