

Application Notes and Protocols for Imaging Fluorescently-Labeled PhoPS

Author: BenchChem Technical Support Team. **Date:** April 2026

Compound of Interest

Compound Name: *PhoPS*
Cat. No.: *B15565165*

[Get Quote](#)

For Researchers, Scientists, and Drug Development Professionals

These application notes provide a comprehensive guide to utilizing fluorescently-labeled **PhoPS**, a key bacterial response regulator, for cellular imaging. Understanding the localization and dynamics of **PhoPS** within living bacteria is crucial for elucidating its role in virulence and for the development of novel antimicrobial drugs.[1] This document outlines the PhoP/PhoQ signaling pathway, provides detailed protocols for creating and imaging a fluorescently-labeled **PhoPS**-GFP fusion protein, and presents quantitative data on suitable fluorescent proteins.

Introduction to the PhoP/PhoQ Two-Component System

The PhoP/PhoQ system is a highly conserved two-component signal transduction system in Gram-negative bacteria, playing a pivotal role in sensing environmental cues and regulating gene expression.[1][2] This system is integral to bacterial virulence, adaptation to host environments, and resistance to antimicrobial peptides.[3]

The core components of this system are:

- PhoQ: A transmembrane sensor kinase that detects environmental signals such as low magnesium (Mg^{2+}) concentrations, acidic pH, and the presence of cationic antimicrobial peptides.[1][4][5]
- PhoP: A cytoplasmic response regulator that, upon activation by PhoQ, binds to specific DNA sequences known as "PhoP boxes" to either activate or repress the transcription of target genes.[2][6]

The signaling cascade is initiated when PhoQ senses specific environmental stimuli, leading to its autophosphorylation. The phosphoryl group is then transferred to PhoP.[2] Phosphorylated PhoP dimerizes and binds to DNA, modulating the expression of genes involved in virulence, lipopolysaccharide (LPS) modification, and ion homeostasis.[2][4] Given its critical role in pathogenesis, the PhoP/PhoQ system is an attractive target for the development of new anti-virulence drugs.[6]

PhoP/PhoQ Signaling Pathway

The signaling pathway of the PhoP/PhoQ system can be summarized as follows: In environments with low Mg^{2+} concentration, such as within a macrophage phagosome, the sensor kinase PhoQ undergoes a conformational change, leading to its autophosphorylation at a conserved histidine residue.[2] The activated PhoQ then transfers the phosphoryl group to a conserved aspartate residue on the response regulator PhoP.[2] This phosphorylation event induces the dimerization of PhoP, which increases its affinity for specific DNA binding sites (PhoP boxes) in the promoter regions of target genes.[2] This binding can either activate or repress gene transcription, leading to a coordinated cellular response to the environmental stimulus.

PhoP/PhoQ Signaling Pathway

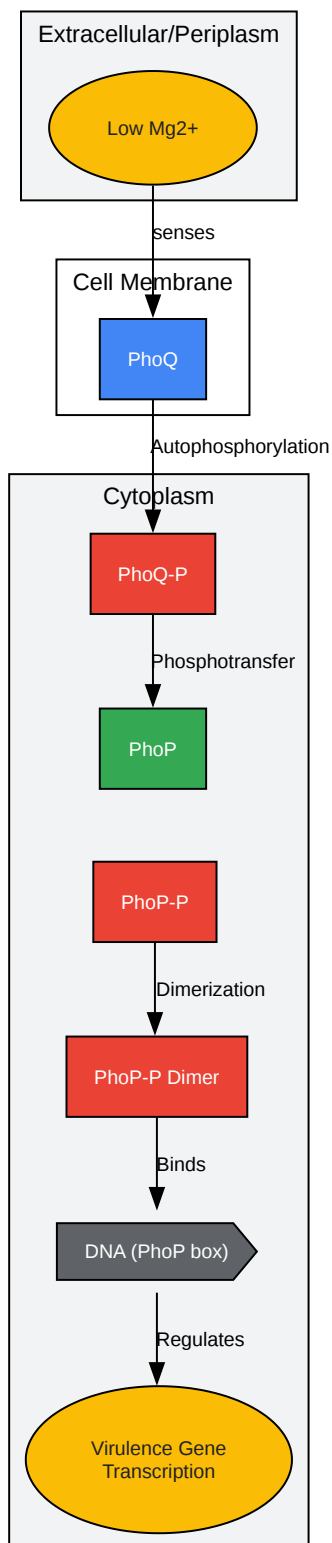

[Click to download full resolution via product page](#)

PhoP/PhoQ signaling cascade.

Application: Imaging PhoPS to Monitor Bacterial Virulence

Visualizing the subcellular localization and dynamics of **PhoPS** in real-time provides a powerful tool for understanding its function and for screening potential inhibitors. By fluorescently labeling **PhoPS**, researchers can directly observe its response to different stimuli, its interaction with the bacterial chromosome, and the effects of drug candidates on its activity.

Recommended Method: PhoPS-GFP Fusion Proteins

The most common and specific method for fluorescently labeling intracellular proteins in live bacteria is through the creation of a genetically encoded fusion protein.[7] This involves fusing the coding sequence of a fluorescent protein (FP), such as Green Fluorescent Protein (GFP), to the N- or C-terminus of the *phoP* gene.[7][8] This creates a single polypeptide chain, **PhoPS-GFP**, that retains the function of **PhoPS** while being fluorescent.

Advantages of FP fusions:

- **High Specificity:** The fluorescent label is directly attached to the protein of interest, minimizing off-target labeling.
- **Live-Cell Imaging:** Allows for the observation of **PhoPS** dynamics in living, unperturbed cells. [8]
- **Defined Stoichiometry:** Each **PhoPS** molecule is labeled with a single fluorescent protein.

Considerations:

- **Potential for Dysfunction:** The addition of the FP tag (~27 kDa) could potentially interfere with the normal function or localization of **PhoPS**. It is crucial to verify that the fusion protein retains its biological activity.[7]
- **Choice of Fluorescent Protein:** The brightness, photostability, and maturation time of the FP will impact the quality of the imaging data.[9][10]

Quantitative Data on Fluorescent Proteins

The choice of the fluorescent protein is critical for successful imaging experiments. The following table summarizes the key properties of several commonly used monomeric fluorescent proteins suitable for creating fusions.

Fluorescent Protein	Excitation Max (nm)	Emission Max (nm)	Relative Brightness ¹	Photostability ²	Reference(s)
EGFP	488	507	1.00	Moderate	[9]
mEmerald	487	509	1.19	Moderate	[11]
mNeonGreen	506	517	2.63	High	[12]
mCherry	587	610	0.39	High	[9][10]
mScarlet	569	594	1.75	Moderate	[11]
mStayGold	516	528	~3.0 (vs EGFP)	Very High	[11]

¹Relative brightness is a product of the extinction coefficient and quantum yield, normalized to EGFP.[9] ²Photostability is a measure of how resistant the fluorophore is to photobleaching under illumination.

Experimental Protocols

Protocol 1: Construction of a PhoPS-GFP Fusion Plasmid

This protocol describes the generation of a plasmid for the expression of a C-terminal **PhoPS-GFP** fusion protein in *E. coli*.

Protocol 1: PhoPS-GFP Fusion Plasmid Construction

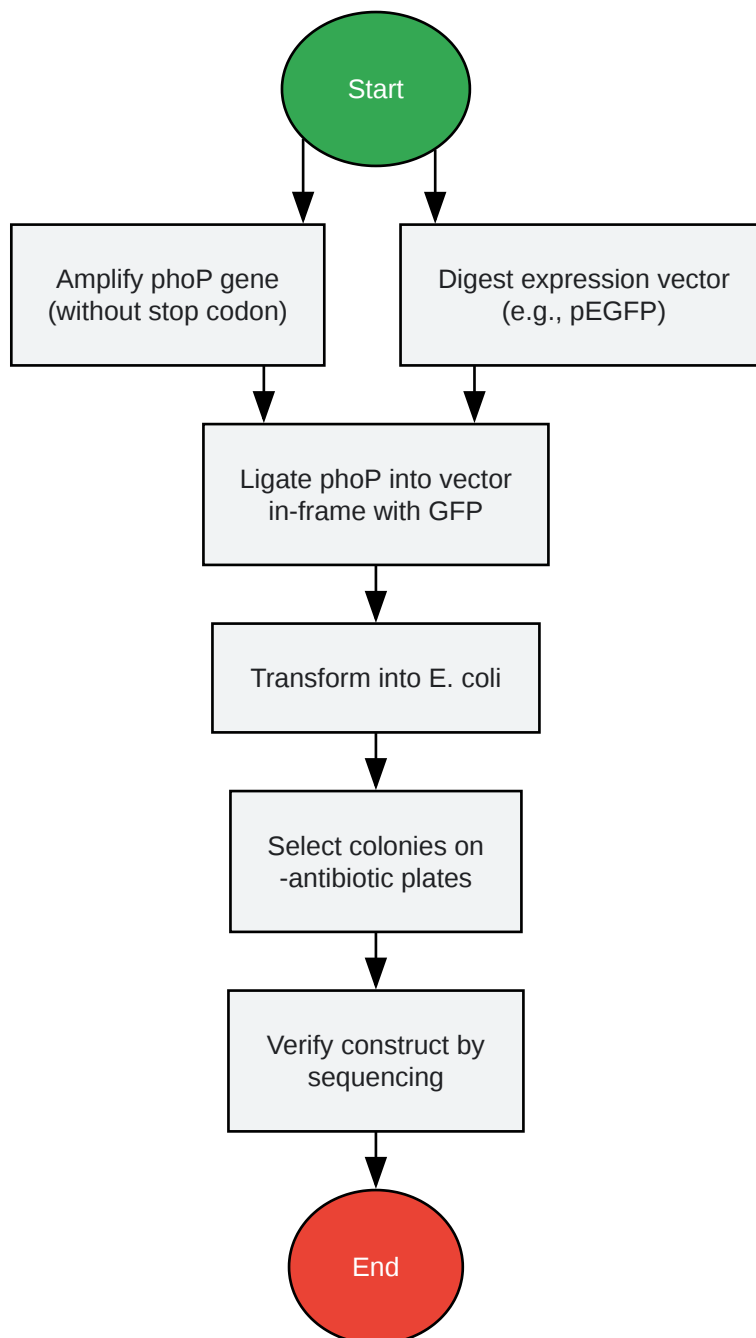

[Click to download full resolution via product page](#)

Workflow for **PhoPS**-GFP plasmid construction.

Materials:

- Bacterial strain containing the phoP gene (e.g., E. coli K-12)

- High-fidelity DNA polymerase
- Primers for phoP amplification (forward and reverse, with appropriate restriction sites and removing the stop codon)
- Expression vector containing a GFP gene (e.g., pEGFP)
- Restriction enzymes
- T4 DNA ligase
- Competent E. coli cells for cloning (e.g., DH5α)
- LB agar plates with appropriate antibiotic

Method:

- **Primer Design:** Design primers to amplify the full-length phoP gene from the bacterial genome. The forward primer should include a restriction site present in the multiple cloning site (MCS) of the expression vector. The reverse primer should also contain a restriction site from the MCS and exclude the native stop codon of phoP to allow for in-frame fusion with the downstream GFP coding sequence.
- **PCR Amplification:** Perform PCR using high-fidelity DNA polymerase to amplify the phoP gene.
- **Purification:** Purify the PCR product using a commercial PCR purification kit.
- **Digestion:** Digest both the purified PCR product and the expression vector with the selected restriction enzymes.
- **Ligation:** Ligate the digested phoP insert into the digested vector using T4 DNA ligase.
- **Transformation:** Transform the ligation mixture into competent E. coli cells.
- **Selection:** Plate the transformed cells on LB agar plates containing the appropriate antibiotic for the expression vector. Incubate overnight at 37°C.

- Verification: Select several colonies and grow them in liquid culture. Isolate the plasmid DNA and verify the correct insertion and orientation of the *phoP* gene by restriction digest and DNA sequencing.

Protocol 2: Expression and Imaging of PhoPS-GFP in Live Bacteria

This protocol outlines the expression of the **PhoPS-GFP** fusion protein and its visualization using fluorescence microscopy.

Protocol 2: Expression and Imaging Workflow

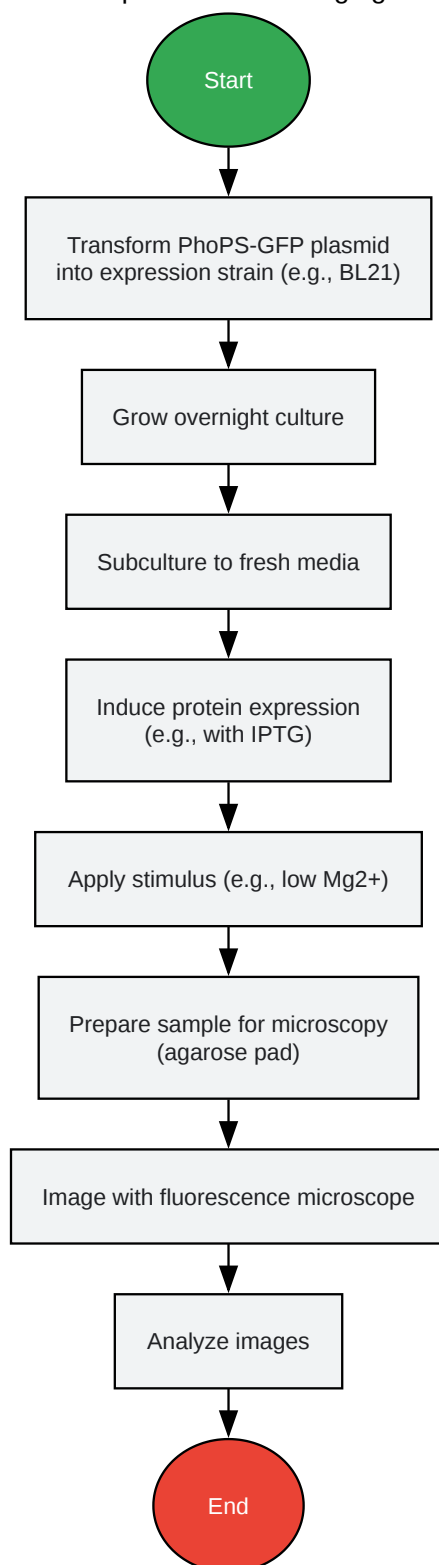

[Click to download full resolution via product page](#)

Workflow for **PhoPS**-GFP expression and imaging.

Materials:

- E. coli expression strain (e.g., BL21(DE3))
- Verified **PhoPS**-GFP expression plasmid
- LB medium with appropriate antibiotic
- Inducing agent (e.g., IPTG, if using an inducible promoter)
- Minimal medium with high (10 mM) and low (10 μ M) MgCl₂
- Glass slides and coverslips
- Agarose
- Fluorescence microscope with appropriate filter sets for GFP (e.g., 488 nm excitation, 510-550 nm emission)

Method:

- Transformation: Transform the verified **PhoPS**-GFP plasmid into an appropriate E. coli expression strain.
- Overnight Culture: Inoculate a single colony into LB medium with the selective antibiotic and grow overnight at 37°C with shaking.
- Subculture: The next day, dilute the overnight culture into fresh minimal medium with high MgCl₂ and grow to mid-log phase (OD₆₀₀ \approx 0.4-0.6).
- Induction: If using an inducible promoter, add the inducing agent (e.g., 0.1-1 mM IPTG) and continue to grow for 2-3 hours to allow for protein expression and maturation of the GFP chromophore.
- Stimulation: To observe the effect of PhoP activation, centrifuge the cells and resuspend them in minimal medium with low MgCl₂. Incubate for a specified time (e.g., 30-60 minutes). A control sample should be resuspended in high MgCl₂ medium.

- **Sample Preparation:** Prepare an agarose pad by melting 1.5% agarose in minimal medium and pipetting a small drop onto a glass slide. Allow it to solidify. Place a small volume (1-2 μL) of the bacterial culture onto a coverslip and then gently place the coverslip onto the agarose pad.
- **Fluorescence Microscopy:** Image the cells using a fluorescence microscope. Use the appropriate filter set for GFP. Acquire both fluorescence and phase-contrast or DIC images to visualize the cell outlines.
- **Image Analysis:** Analyze the acquired images to determine the subcellular localization of the **PhoPS**-GFP fusion protein. Look for changes in localization, such as the formation of distinct foci, upon stimulation with low Mg^{2+} , which may indicate binding to the nucleoid.

Protocol 3: Verifying the Functional Integrity of PhoPS-GFP

It is essential to confirm that the **PhoPS**-GFP fusion protein is functional. This can be achieved by a complementation assay using a phoP deletion mutant.

Method:

- Construct a phoP deletion mutant in a bacterial strain that has a PhoP-regulated reporter gene (e.g., a promoter fusion to lacZ).
- Transform the **PhoPS**-GFP expression plasmid into the phoP deletion mutant.
- Perform a reporter assay (e.g., β -galactosidase assay) under both high and low Mg^{2+} conditions.
- Compare the results to the wild-type strain and the phoP deletion mutant carrying an empty vector. If the **PhoPS**-GFP fusion protein is functional, it should restore the regulation of the reporter gene in the deletion mutant in response to Mg^{2+} levels.

Drug Development Applications

The use of fluorescently-labeled **PhoPS** provides a powerful platform for high-throughput screening of compounds that inhibit the PhoP/PhoQ system. A successful inhibitor might

prevent the phosphorylation of PhoP, its dimerization, or its binding to DNA. These events can be monitored by observing changes in the localization of **PhoPS**-GFP within the cell. For example, a compound that prevents PhoP from binding to the bacterial chromosome would result in a diffuse cytoplasmic fluorescence signal even under activating conditions. This cell-based assay can be used to identify and characterize novel anti-virulence agents targeting this critical bacterial regulatory system.[6]

Need Custom Synthesis?

BenchChem offers custom synthesis for rare earth carbides and specific isotopic labeling.

Email: info@benchchem.com or [Request Quote Online](#).

References

- 1. [Frontiers | An updated overview on the bacterial PhoP/PhoQ two-component signal transduction system \[frontiersin.org\]](#)
- 2. [proteopedia.org \[proteopedia.org\]](#)
- 3. [escholarship.mcgill.ca \[escholarship.mcgill.ca\]](#)
- 4. [researchgate.net \[researchgate.net\]](#)
- 5. [Allosteric mechanism of signal transduction in the two-component system histidine kinase PhoQ - PMC \[pmc.ncbi.nlm.nih.gov\]](#)
- 6. [researchgate.net \[researchgate.net\]](#)
- 7. [blog.addgene.org \[blog.addgene.org\]](#)
- 8. [bio.libretexts.org \[bio.libretexts.org\]](#)
- 9. [Quantitative Assessment of Fluorescent Proteins - PMC \[pmc.ncbi.nlm.nih.gov\]](#)
- 10. [tsienlab.ucsd.edu \[tsienlab.ucsd.edu\]](#)
- 11. [Quantitative comparison of fluorescent proteins using protein nanocages in live cells - PMC \[pmc.ncbi.nlm.nih.gov\]](#)
- 12. [researchgate.net \[researchgate.net\]](#)
- To cite this document: BenchChem. [Application Notes and Protocols for Imaging Fluorescently-Labeled PhoPS]. BenchChem, [2026]. [Online PDF]. Available at: [\[https://www.benchchem.com/product/b15565165/docs#application-notes-and-protocols-for-imaging-fluorescently-labeled-phops\]](https://www.benchchem.com/product/b15565165/docs#application-notes-and-protocols-for-imaging-fluorescently-labeled-phops)

Disclaimer & Data Validity:

The information provided in this document is for Research Use Only (RUO) and is strictly not intended for diagnostic or therapeutic procedures. While BenchChem strives to provide accurate protocols, we make no warranties, express or implied, regarding the fitness of this product for every specific experimental setup.

Technical Support: The protocols provided are for reference purposes. Unsure if this reagent suits your experiment?

Need Industrial/Bulk Grade? [Request Custom Synthesis Quote](#)

BenchChem

Our mission is to be the trusted global source of essential and advanced chemicals, empowering scientists and researchers to drive progress in science and industry.

Contact

Address: 3281 E Guasti Rd
Ontario, CA 91761, United States
Phone: (601) 213-4426
Email: info@benchchem.com

[Contact our Ph.D. Support Team for a compatibility check](#)