

Application Notes and Protocols for GS-9770 in Cell Culture Experiments

Author: BenchChem Technical Support Team. **Date:** April 2026

Compound of Interest

Compound Name: GS-9770
Cat. No.: B15565444

[Get Quote](#)

For Researchers, Scientists, and Drug Development Professionals

Introduction

GS-9770 is a potent, non-peptidomimetic inhibitor of the human immunodeficiency virus (HIV) protease, an enzyme critical for the viral life cycle.[1][2][3][4] By selectively targeting HIV protease, **GS-9770** blocks the cleavage of viral polyproteins, preventing the maturation of new, infectious virions.[5] These application notes provide detailed protocols for the preparation of **GS-9770** solutions and its use in cell culture-based antiviral and cytotoxicity assays.

Mechanism of Action

GS-9770 is an orally active inhibitor of HIV protease with a high affinity for the enzyme's active site. The HIV replication cycle involves the assembly of new viral particles that are initially non-infectious. The viral protease is responsible for cleaving large precursor polyproteins (Gag and Gag-Pol) into smaller, functional proteins that are essential for the final steps of viral maturation. **GS-9770** competitively inhibits this enzymatic activity, leading to the production of immature and non-infectious viral particles.

Quantitative Data Summary

The following tables summarize the key quantitative data for **GS-9770** based on available research.

Table 1: In Vitro Inhibitory Activity of **GS-9770**

Parameter	Value	Target	Reference
Ki (inhibition constant)	0.16 nM	Recombinant HIV-1 Protease	
EC50 (half-maximal effective concentration)	1.9 - 26 nM	HIV-1 Strains	
EC50 (half-maximal effective concentration)	26 nM	HIV-2 Strains	

Table 2: Recommended Cell Lines for **GS-9770** Assays

Cell Line	Cell Type	Typical Use
MT-2	Human T-cell leukemia	Antiviral activity, cytopathic effect assays
MT-4	Human T-cell leukemia	Antiviral activity, cytopathic effect assays
PBMCs	Peripheral Blood Mononuclear Cells	Antiviral activity, cytotoxicity in primary cells

Experimental Protocols

Protocol 1: Preparation of **GS-9770** Stock Solution

This protocol describes the preparation of a 10 mM stock solution of **GS-9770** in Dimethyl Sulfoxide (DMSO).

Materials:

- **GS-9770** powder (CAS: 2306328-43-6)
- Anhydrous Dimethyl Sulfoxide (DMSO)
- Sterile, amber microcentrifuge tubes
- Calibrated analytical balance
- Vortex mixer

Procedure:

- **Pre-weighing Preparation:** Allow the **GS-9770** powder vial to equilibrate to room temperature before opening to prevent condensation.
- **Weighing:** Accurately weigh the desired amount of **GS-9770** powder. For a 10 mM stock solution, the required mass can be calculated using the molecular weight of **GS-9770** (811.16 g/mol).
- **Dissolution:** Add the appropriate volume of anhydrous DMSO to the **GS-9770** powder. For example, to prepare 1 mL of a 10 mM stock solution, add 1 mL of DMSO to 8.11 mg of **GS-9770**.
- **Mixing:** Vortex the solution thoroughly until the **GS-9770** is completely dissolved. Gentle warming in a water bath (not exceeding 37°C) may be used to aid dissolution if necessary.
- **Aliquoting and Storage:** Aliquot the stock solution into sterile, amber microcentrifuge tubes to avoid repeated freeze-thaw cycles. Store the aliquots at -20°C for long-term storage. Under these conditions, the stock solution is expected to be stable for several months.

Protocol 2: Antiviral Activity Assay in MT-4 Cells

This protocol details a cell-based assay to determine the antiviral activity of **GS-9770** against HIV-1 using the MT-4 cell line.

Materials:

- MT-4 cells
- Complete RPMI-1640 medium (supplemented with 10% Fetal Bovine Serum, 100 U/mL penicillin, and 100 µg/mL streptomycin)
- HIV-1 stock (e.g., IIIB strain)
- **GS-9770** stock solution (10 mM in DMSO)
- 96-well flat-bottom microtiter plates
- MTT reagent (3-(4,5-dimethylthiazol-2-yl)-2,5-diphenyltetrazolium bromide)
- Solubilization buffer (e.g., 10% SDS in 0.01 M HCl)
- Plate reader

Procedure:

- Cell Seeding: Seed MT-4 cells into a 96-well plate at a density of 2×10^4 cells per well in 100 µL of complete RPMI-1640 medium.
- Compound Dilution: Prepare serial dilutions of the **GS-9770** stock solution in complete RPMI-1640 medium. A typical starting concentration for the highest dose might be 1 µM, with subsequent 3-fold or 5-fold dilutions. Remember to include a DMSO vehicle control (at the same final concentration as the highest **GS-9770** dose).
- Infection and Treatment: Add 50 µL of the diluted **GS-9770** to the appropriate wells. Subsequently, add 50 µL of HIV-1 stock (at a pre-determined multiplicity of infection, MOI) to all wells except the uninfected control wells.
- Incubation: Incubate the plate at 37°C in a humidified 5% CO₂ incubator for 4-5 days.
- MTT Assay:
 - Add 20 µL of MTT solution (5 mg/mL in PBS) to each well.
 - Incubate for 4 hours at 37°C.

- Add 100 μ L of solubilization buffer to each well and incubate overnight at 37°C.
- Data Analysis: Measure the absorbance at 570 nm using a plate reader. The percentage of cell protection can be calculated relative to the uninfected and untreated virus-infected controls. The EC50 value can be determined by plotting the percentage of protection against the log of the **GS-9770** concentration and fitting the data to a dose-response curve.

Protocol 3: Cytotoxicity Assay in PBMCs

This protocol describes how to assess the cytotoxicity of **GS-9770** in human Peripheral Blood Mononuclear Cells (PBMCs).

Materials:

- Human PBMCs (isolated by Ficoll-Paque density gradient centrifugation)
- Complete RPMI-1640 medium
- **GS-9770** stock solution (10 mM in DMSO)
- 96-well U-bottom microtiter plates
- Cell viability reagent (e.g., CellTiter-Glo® Luminescent Cell Viability Assay)
- Luminometer

Procedure:

- Cell Seeding: Seed PBMCs into a 96-well plate at a density of 1×10^5 cells per well in 100 μ L of complete RPMI-1640 medium.
- Compound Dilution: Prepare serial dilutions of **GS-9770** in complete RPMI-1640 medium. It is important to test a wide range of concentrations to determine the CC50 (50% cytotoxic concentration).
- Treatment: Add 100 μ L of the diluted **GS-9770** to the appropriate wells. Include a DMSO vehicle control.

- Incubation: Incubate the plate at 37°C in a humidified 5% CO₂ incubator for 48-72 hours.
- Viability Assay:
 - Allow the plate and the viability reagent to equilibrate to room temperature.
 - Add the viability reagent to each well according to the manufacturer's instructions.
 - Mix the contents on an orbital shaker for 2 minutes to induce cell lysis.
 - Incubate at room temperature for 10 minutes to stabilize the luminescent signal.
- Data Analysis: Measure the luminescence using a plate reader. The percentage of cytotoxicity is calculated relative to the untreated control cells. The CC50 value can be determined from a dose-response curve.

Visualizations

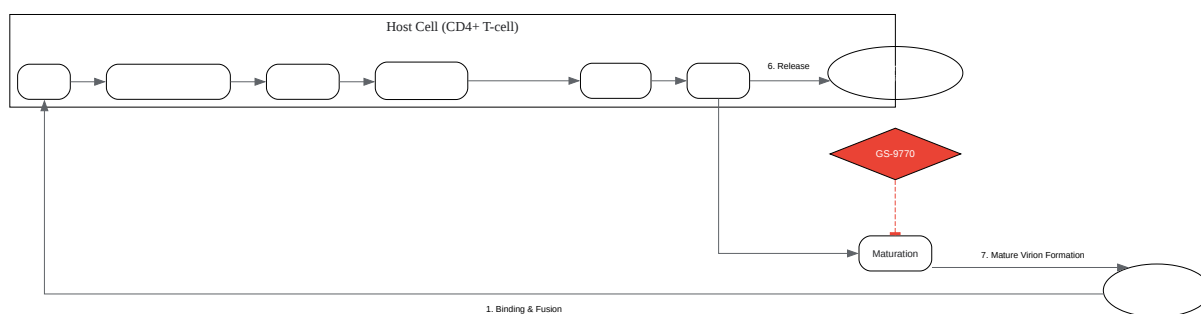

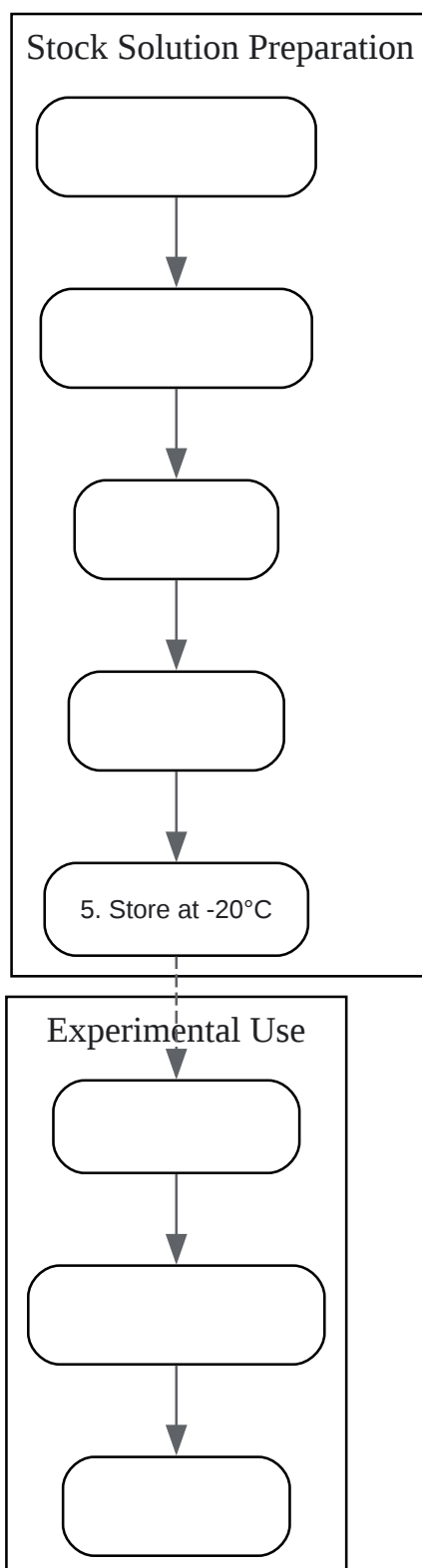

[Click to download full resolution via product page](#)

Need Custom Synthesis?

BenchChem offers custom synthesis for rare earth carbides and specific isotopic labeling.

Email: info@benchchem.com or [Request Quote Online](#).

References

- 1. GS-9770 Datasheet DC Chemicals [dcchemicals.com]
- 2. GS-9770|CAS 2306328-43-6|DC Chemicals [dcchemicals.com]
- 3. medchemexpress.com [medchemexpress.com]
- 4. medchemexpress.com [medchemexpress.com]
- 5. HIV Drugs and the HIV Lifecycle | The Well Project [thewellproject.org]
- To cite this document: BenchChem. [Application Notes and Protocols for GS-9770 in Cell Culture Experiments]. BenchChem, [2026]. [Online PDF]. Available at: [<https://www.benchchem.com/product/b15565444/docs#application-notes-and-protocols-for-gs-9770-in-cell-culture-experiments>]

Disclaimer & Data Validity:

The information provided in this document is for Research Use Only (RUO) and is strictly not intended for diagnostic or therapeutic procedures. While BenchChem strives to provide accurate protocols, we make no warranties, express or implied, regarding the fitness of this product for every specific experimental setup.

Technical Support: The protocols provided are for reference purposes. Unsure if this reagent suits your experiment?

Need Industrial/Bulk Grade? [Request Custom Synthesis Quote](#)

BenchChem

Our mission is to be the trusted global source of essential and advanced chemicals, empowering scientists and researchers to drive progress in science and industry.

Contact

Address: 3281 E Guasti Rd

Ontario, CA 91761, United States

Phone: (601) 213-4426

Email: info@benchchem.com

[Contact our Ph.D. Support Team for a compatibility check](#)