

Application Notes and Protocols for Cell-Based Assays of FPPS Inhibitors

Author: BenchChem Technical Support Team. **Date:** April 2026

Compound of Interest

Compound Name: TH-Z145
Cat. No.: B15565154

[Get Quote](#)

Introduction

Farnesyl pyrophosphate synthase (FPPS) is a critical enzyme in the mevalonate pathway, responsible for synthesizing farnesyl pyrophosphate (FPP).[1][2] FPP is a key metabolic intermediate, serving as a precursor for the biosynthesis of essential molecules like cholesterol, dolichol, ubiquinone, and for the prenylation of proteins.[3] Protein prenylation, the attachment of farnesyl or geranylgeranyl groups to small GTPases such as Ras, Rho, and Rac, is vital for their proper membrane localization and function in cellular signaling pathways that control cell growth, differentiation, and survival.[3][4]

Inhibition of FPPS disrupts these processes, making it an attractive therapeutic target for a range of diseases. Nitrogen-containing bisphosphonates (N-BPs), such as zoledronic acid and alendronate, are potent FPPS inhibitors widely used to treat bone resorption disorders like osteoporosis. By inhibiting FPPS in osteoclasts, N-BPs prevent the prenylation of proteins required for osteoclast function and survival, thereby reducing bone loss. Furthermore, there is growing interest in developing FPPS inhibitors for oncology, as disrupting the function of oncogenic proteins like Ras can inhibit tumor growth.

These application notes provide detailed protocols for key cell-based assays to evaluate the efficacy and mechanism of action of FPPS inhibitors.

Signaling Pathways and Experimental Overviews

The Mevalonate Pathway and FPPS Inhibition

FPPS catalyzes the sequential condensation of isopentenyl pyrophosphate (IPP) with dimethylallyl pyrophosphate (DMAPP) to form geranyl pyrophosphate (GPP), and subsequently, the condensation of GPP with another IPP molecule to yield FPP. FPPS inhibitors block this process, leading to a depletion of FPP and its downstream derivative, geranylgeranyl pyrophosphate (GGPP), while causing an accumulation of the upstream substrate, IPP.

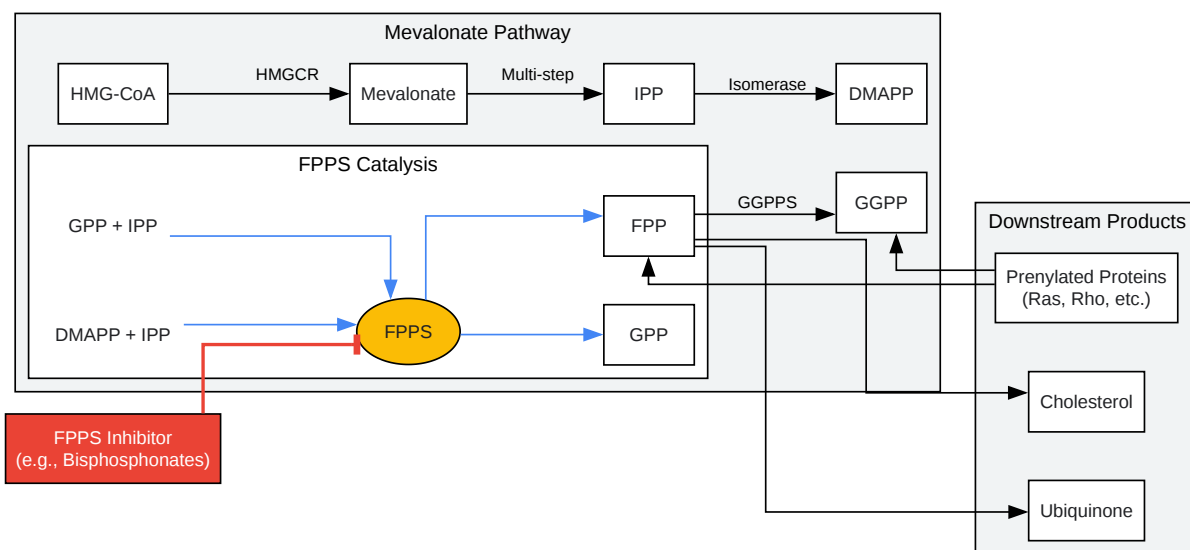

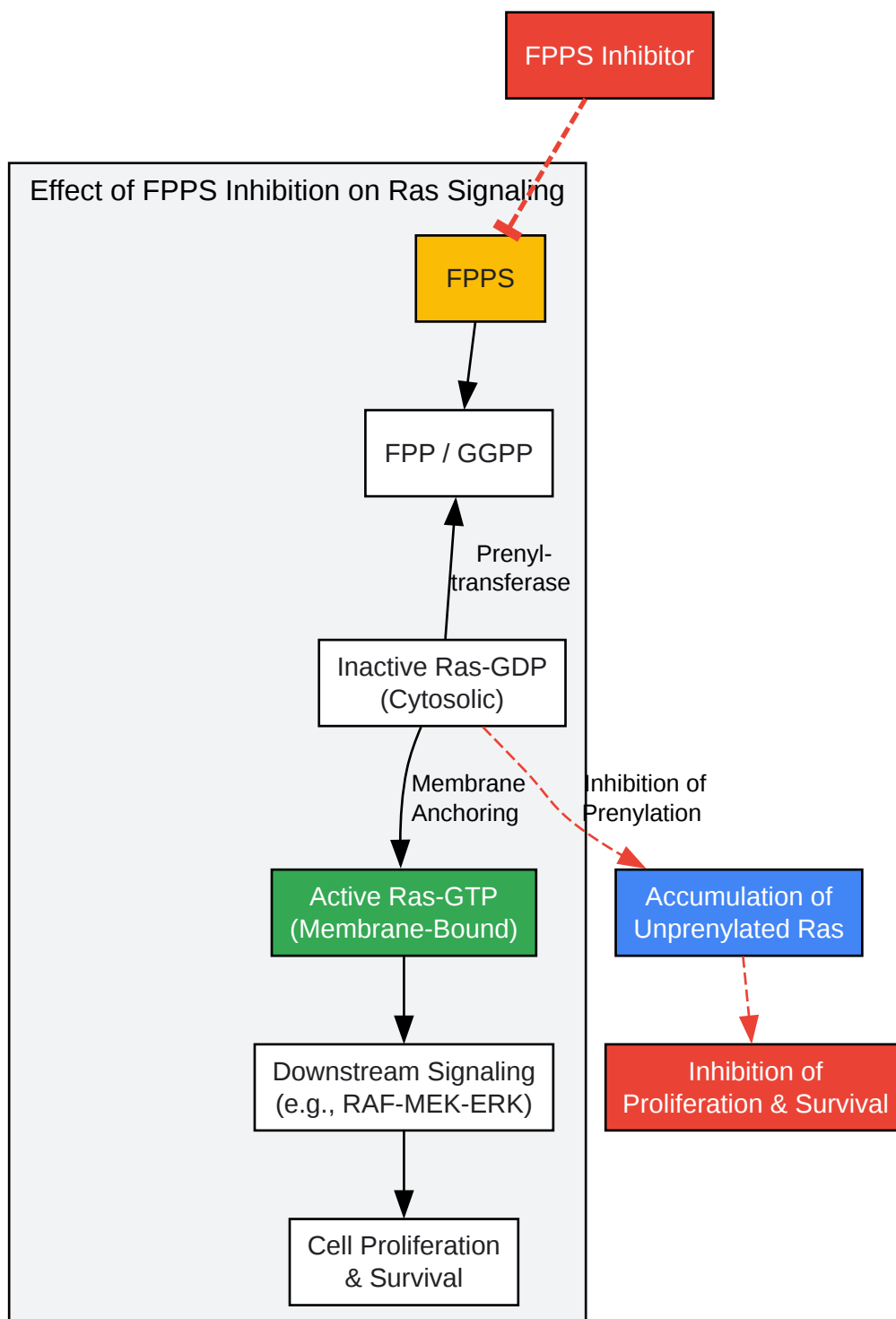

1. Seed Cells in 96-well plate
2. Add serial dilutions of FPPS Inhibitor
3. Incubate (e.g., 72 hours)
4. Add MTT Reagent
5. Incubate (4h) & Add Solubilizer (DMSO)
6. Measure Absorbance (570 nm)
7. Calculate % Viability and IC50 Value

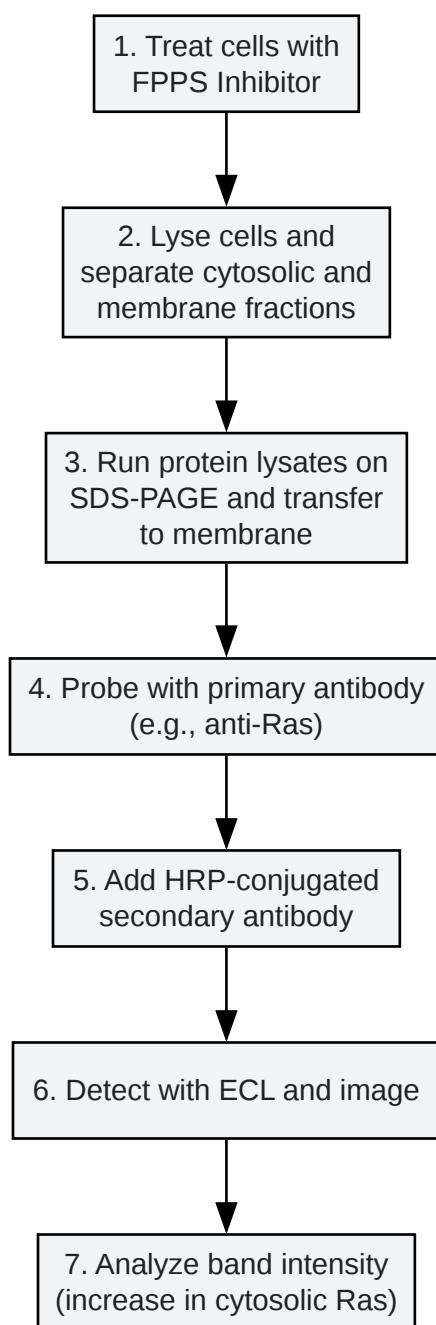

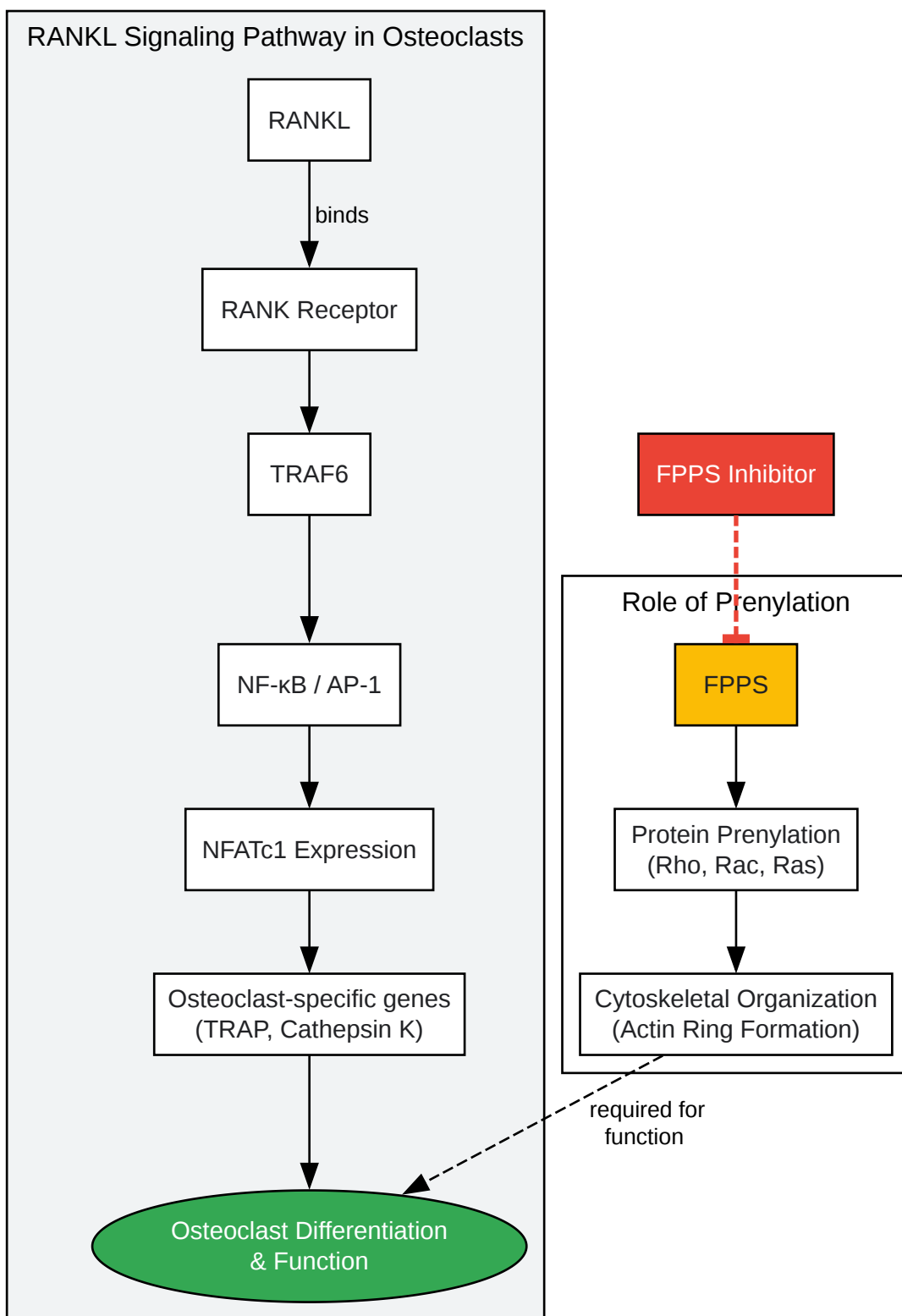

[Click to download full resolution via product page](#)

Need Custom Synthesis?

BenchChem offers custom synthesis for rare earth carbides and specific isotopic labeling.

Email: info@benchchem.com or [Request Quote Online](#).

References

- [1. spandidos-publications.com \[spandidos-publications.com\]](https://spandidos-publications.com)
- [2. lirias.kuleuven.be \[lirias.kuleuven.be\]](https://lirias.kuleuven.be)
- [3. Human farnesyl pyrophosphate synthase is allosterically inhibited by its own product - PMC \[pmc.ncbi.nlm.nih.gov\]](https://pubmed.ncbi.nlm.nih.gov/12345678/)
- [4. The inhibition of human farnesyl pyrophosphate synthase by nitrogen-containing bisphosphonates. Elucidating the role of active site threonine 201 and tyrosine 204 residues using enzyme mutants - PMC \[pmc.ncbi.nlm.nih.gov\]](https://pubmed.ncbi.nlm.nih.gov/12345679/)
- To cite this document: BenchChem. [Application Notes and Protocols for Cell-Based Assays of FPPS Inhibitors]. BenchChem, [2026]. [Online PDF]. Available at: [\[https://www.benchchem.com/product/b15565154/docs#application-notes-and-protocols-for-cell-based-assays-of-fpps-inhibitors\]](https://www.benchchem.com/product/b15565154/docs#application-notes-and-protocols-for-cell-based-assays-of-fpps-inhibitors)

Disclaimer & Data Validity:

The information provided in this document is for Research Use Only (RUO) and is strictly not intended for diagnostic or therapeutic procedures. While BenchChem strives to provide accurate protocols, we make no warranties, express or implied, regarding the fitness of this product for every specific experimental setup.

Technical Support: The protocols provided are for reference purposes. Unsure if this reagent suits your experiment?

Need Industrial/Bulk Grade? [Request Custom Synthesis Quote](#)

BenchChem

Our mission is to be the trusted global source of essential and advanced chemicals, empowering scientists and researchers to drive progress in science and industry.

Contact

Address: 3281 E Guasti Rd

Ontario, CA 91761, United States

Phone: (601) 213-4426

Email: info@benchchem.com

[Contact our Ph.D. Support Team for a compatibility check](#)