

# Application Notes and Protocols for 44-Homooligomycin B in Combination Chemotherapy

**Author:** BenchChem Technical Support Team. **Date:** April 2026

## Compound of Interest

Compound Name: 44-Homooligomycin B

Cat. No.: B15565327

[Get Quote](#)

Disclaimer: Due to the limited availability of published research specifically on "**44-Homooligomycin B**" in combination with other chemotherapy agents, this document utilizes "Oligomycin," a closely related and well-studied ATP synthase inhibitor, as a proxy. The experimental protocols and data presented are based on studies involving Oligomycin and are intended to provide a foundational framework for research with **44-Homooligomycin B**. Researchers should validate these protocols and findings for **44-Homooligomycin B**.

## Introduction

**44-Homooligomycin B** is an antitumor antibiotic that, like other oligomycins, is expected to function as a potent inhibitor of mitochondrial  $F_0F_1$ -ATP synthase.[1] This inhibition disrupts cellular energy metabolism by blocking oxidative phosphorylation (OXPHOS), leading to a decrease in intracellular ATP production. In cancer cells, which often exhibit a high metabolic rate, this disruption can be a potent therapeutic strategy.

The combination of an OXPHOS inhibitor like **44-Homooligomycin B** with other chemotherapy agents that target different cellular processes presents a promising approach to enhance anticancer efficacy, overcome drug resistance, and potentially reduce side effects by allowing

for lower doses of each agent. This document outlines the application of **44-Homooligomycin B** in combination with three distinct classes of anticancer agents:

- Doxorubicin: An anthracycline antibiotic that intercalates into DNA and inhibits topoisomerase II, leading to DNA damage and apoptosis.
- Cisplatin: A platinum-based chemotherapeutic that forms DNA adducts, triggering DNA damage responses and apoptosis.
- 2-Deoxy-D-glucose (2-DG): A glucose analog that inhibits glycolysis, another major pathway for ATP production in cancer cells.

The rationale behind these combinations is to create a dual metabolic attack (OXPHOS and glycolysis inhibition) or to sensitize cancer cells to DNA-damaging agents by depleting their energy reserves needed for DNA repair and survival.

## Synergistic Effects of Oligomycin in Combination Therapy

The synergistic, additive, or antagonistic effects of drug combinations can be quantified using the Combination Index (CI), commonly calculated using the Chou-Talalay method. A CI value less than 1 indicates synergy, a value equal to 1 indicates an additive effect, and a value greater than 1 indicates antagonism.

### Combination with Doxorubicin

Studies have shown that Oligomycin can enhance the cytotoxic effects of doxorubicin, particularly in drug-resistant cancer cell lines. This synergy is thought to arise from Oligomycin's ability to deplete cellular ATP, thereby hindering the function of ATP-dependent drug efflux pumps like P-glycoprotein (P-gp), which are often responsible for doxorubicin resistance.[2] The combined treatment leads to increased intracellular doxorubicin accumulation and enhanced apoptosis.[2]

Quantitative Data:

Cell Line	Agent	IC50	Combination IC50	Combination Index (CI)	Reference
Doxorubicin-Resistant HepG2	Doxorubicin	High (Resistance)	Lowered in combination	Synergistic (CI < 1)	[2]
	Oligomycin	Not specified			

Note: Specific IC50 and CI values were not provided in the abstract; however, the study reported that the combined treatment elicited significantly more cell death than individual agents.

## Combination with Cisplatin

The combination of Oligomycin with cisplatin has been shown to enhance cisplatin's cytotoxicity. By inhibiting ATP production, Oligomycin can impair the cancer cells' ability to repair cisplatin-induced DNA damage, a process that is highly energy-dependent. This leads to an accumulation of DNA damage and a more robust apoptotic response.

Quantitative Data:

Cell Line	Agent	IC50	Combination IC50	Combination Index (CI)	Reference
Human Lung Cancer A549	Cisplatin	~7.5 $\mu$ M (48h)	Not specified	Synergistic	[3]
	Oligogalacturonides (OGA)	>100 $\mu$ g/mL			

Note: This study used Oligogalacturonides in combination with cisplatin, showing synergy. While not Oligomycin, it highlights the potential of combining agents that modulate cellular processes with DNA-damaging agents. Specific IC50 values for an Oligomycin-cisplatin combination require further investigation from dedicated studies.

## Combination with 2-Deoxy-D-glucose (2-DG)

The combination of Oligomycin and 2-DG represents a dual blockade of cancer cell metabolism. By inhibiting both OXPHOS and glycolysis, this combination can lead to a severe depletion of cellular ATP, causing catastrophic energy stress and inducing cell death. This approach is particularly effective as it targets the metabolic plasticity of cancer cells, which can often switch between these two energy pathways to survive.

Quantitative Data:

Cell Line	Agent	IC50	Combination Effect	Reference
Breast Cancer (MCF-7)	2-DG	~5-10 mM	Synergistic decrease in ATP levels	[1]
Mitochondria-targeted drugs	Not specified			
AML cell lines	2-DG	Variable	Dose-dependent decrease in viability	[4]
Oligomycin	Variable	Dose-dependent decrease in viability		[4]

Note: While synergy is reported, specific CI values for the Oligomycin and 2-DG combination are not consistently provided across studies. The effect is often measured as a significant decrease in cell viability or ATP levels compared to single-agent treatments.

## Experimental Protocols

### Cell Viability Assay (MTT Assay)

This protocol is used to assess the cytotoxic effects of **44-Homooligomycin B** in combination with other chemotherapy agents.

Materials:

- Cancer cell line of interest
- Complete cell culture medium
- 96-well plates
- **44-Homooligomycin B**, Doxorubicin, Cisplatin, or 2-DG
- MTT (3-(4,5-dimethylthiazol-2-yl)-2,5-diphenyltetrazolium bromide) solution (5 mg/mL in PBS)
- DMSO (Dimethyl sulfoxide)
- Microplate reader

#### Procedure:

- Seed cells in a 96-well plate at a density of 5,000-10,000 cells/well in 100  $\mu$ L of complete medium and incubate for 24 hours.
- Prepare serial dilutions of **44-Homooligomycin B** and the combination agent (Doxorubicin, Cisplatin, or 2-DG) in complete medium.
- Treat the cells with single agents and their combinations at various concentrations. Include untreated control wells.
- Incubate the plates for 48-72 hours.
- Add 10  $\mu$ L of MTT solution to each well and incubate for 4 hours at 37°C.
- Carefully remove the medium and add 100  $\mu$ L of DMSO to each well to dissolve the formazan crystals.
- Measure the absorbance at 570 nm using a microplate reader.
- Calculate the percentage of cell viability relative to the untreated control and determine the IC50 values for each agent and combination. Synergy is then calculated using software like CompuSyn.

## Apoptosis Assay (Annexin V-FITC/PI Staining)

This protocol is used to quantify the induction of apoptosis by the combination treatment.

Materials:

- Cancer cell line of interest
- 6-well plates
- **44-Homooligomycin B** and combination agent
- Annexin V-FITC Apoptosis Detection Kit (containing Annexin V-FITC, Propidium Iodide (PI), and Binding Buffer)
- Flow cytometer

Procedure:

- Seed cells in 6-well plates and allow them to adhere overnight.
- Treat the cells with **44-Homooligomycin B**, the combination agent, and their combination at predetermined concentrations (e.g., IC<sub>50</sub> values) for 24-48 hours.
- Harvest the cells (including floating cells in the medium) by trypsinization and wash with cold PBS.
- Resuspend the cell pellet in 1X Binding Buffer.
- Add 5  $\mu$ L of Annexin V-FITC and 5  $\mu$ L of PI to the cell suspension.
- Incubate for 15 minutes at room temperature in the dark.
- Analyze the cells by flow cytometry within 1 hour.
- Quantify the percentage of cells in early apoptosis (Annexin V+/PI-), late apoptosis (Annexin V+/PI+), and necrosis (Annexin V-/PI+).

## Signaling Pathways and Mechanisms of Action

### Combination of **44-Homooligomycin B** and Doxorubicin

The synergy between an ATP synthase inhibitor and doxorubicin likely involves multiple mechanisms. By depleting ATP, **44-Homooligomycin B** can inhibit the function of ATP-binding cassette (ABC) transporters, such as P-glycoprotein, which are responsible for pumping doxorubicin out of cancer cells. This leads to increased intracellular accumulation of doxorubicin, enhancing its DNA-damaging effects. Furthermore, the energy-depleted state may prevent the cancer cells from mounting an effective DNA damage response, pushing them towards apoptosis.

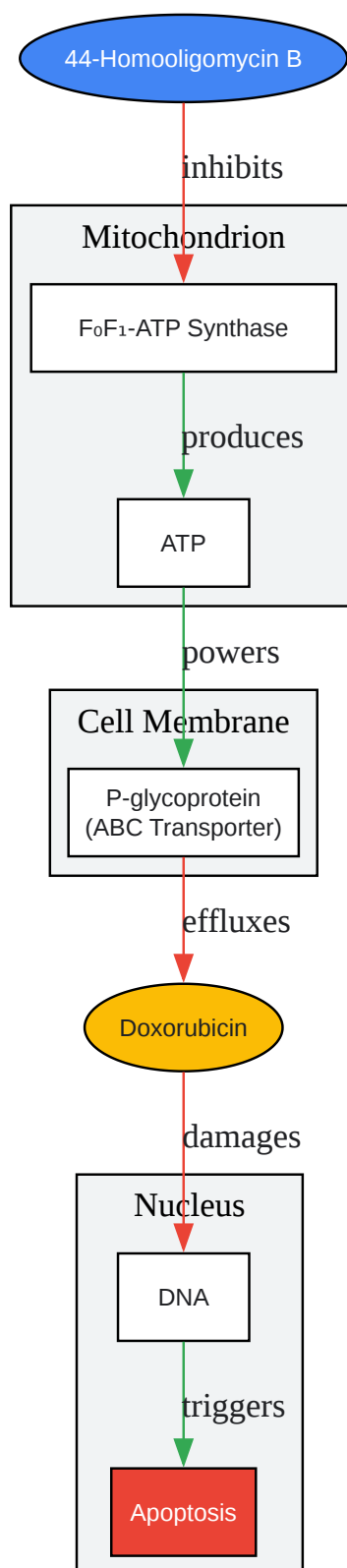

[Click to download full resolution via product page](#)

Caption: Synergistic action of **44-Homooligomycin B** and Doxorubicin.

## Combination of 44-Homooligomycin B and Cisplatin

Cisplatin induces apoptosis primarily through the activation of the intrinsic (mitochondrial) and extrinsic (death receptor) pathways following extensive DNA damage. The combination with **44-Homooligomycin B** can potentiate this effect by depleting the ATP required for DNA repair mechanisms. This leads to an accumulation of irreparable DNA damage, which strongly signals for apoptosis through the p53 and MAPK pathways.

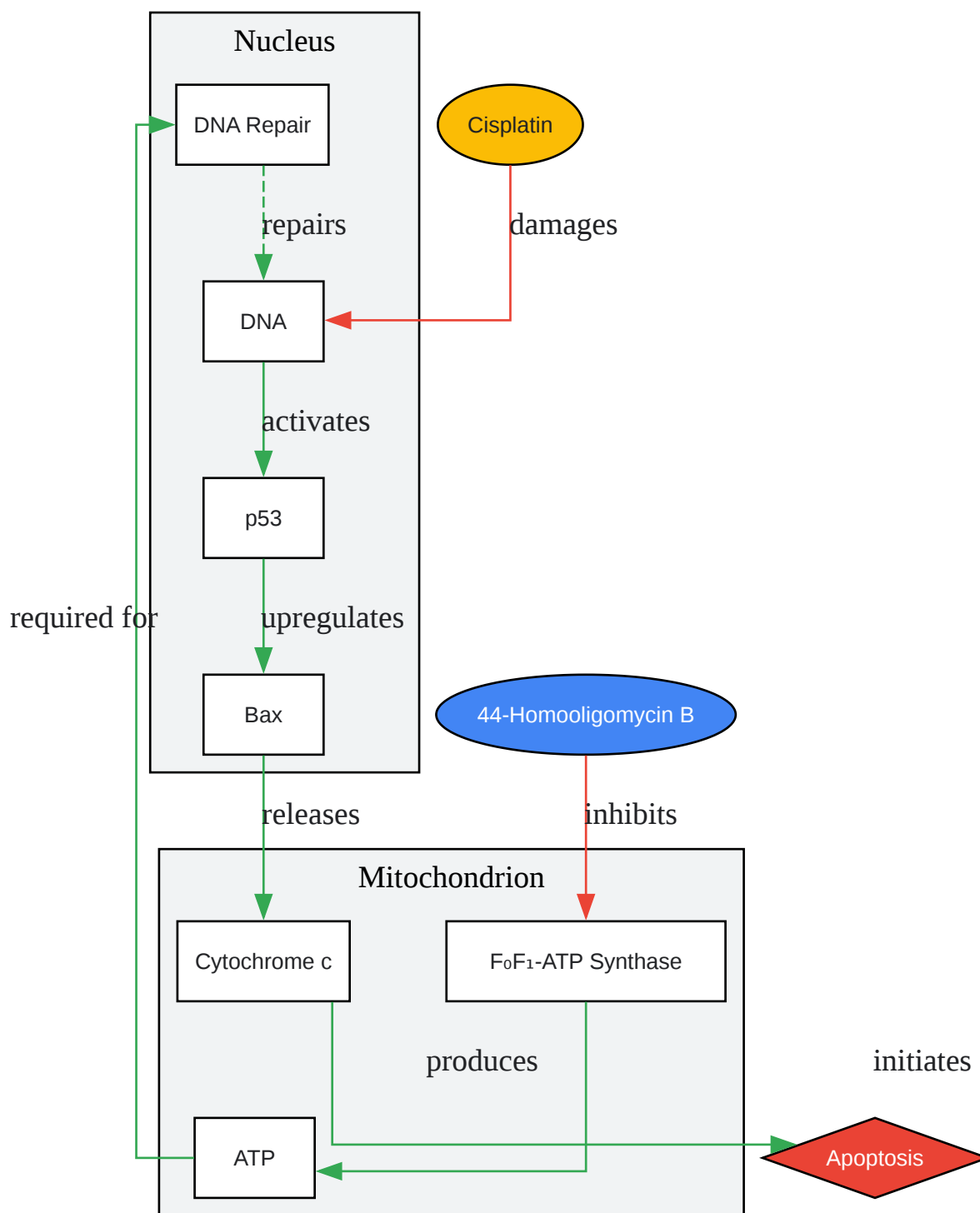

[Click to download full resolution via product page](#)

Caption: **44-Homooligomycin B** enhances Cisplatin-induced apoptosis.

## Combination of 44-Homooligomycin B and 2-Deoxy-D-glucose (2-DG)

This combination targets the two primary energy-producing pathways in cancer cells. By simultaneously inhibiting OXPHOS with **44-Homooligomycin B** and glycolysis with 2-DG, the cell is starved of ATP. This severe energy crisis leads to the activation of AMP-activated protein kinase (AMPK), a master regulator of cellular energy homeostasis. However, with both major ATP sources blocked, the cell is unable to restore energy balance, leading to metabolic collapse and cell death.

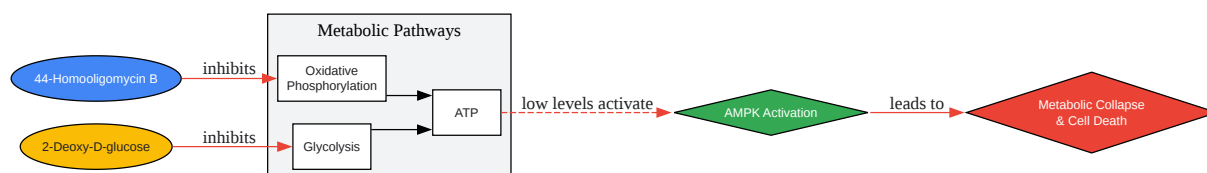

[Click to download full resolution via product page](#)

Caption: Dual metabolic blockade by **44-Homooligomycin B** and 2-DG.

## Conclusion

The combination of **44-Homooligomycin B** with conventional chemotherapy agents like doxorubicin and cisplatin, or with metabolic inhibitors like 2-DG, holds significant therapeutic potential. By targeting the energy metabolism of cancer cells, **44-Homooligomycin B** can sensitize them to other anticancer treatments, potentially leading to more effective and durable responses. The provided protocols and mechanistic insights serve as a starting point for further preclinical investigation into these promising combination therapies. It is imperative to conduct detailed dose-response studies and synergy analyses for **44-Homooligomycin B** to optimize its clinical application.

**Need Custom Synthesis?**

BenchChem offers custom synthesis for rare earth carbides and specific isotopic labeling.

Email: [info@benchchem.com](mailto:info@benchchem.com) or [Request Quote Online](#).

## References

- 1. Mitochondria targeted drugs synergize with 2-deoxyglucose to trigger breast cancer cell death - PMC [[pmc.ncbi.nlm.nih.gov](https://pubmed.ncbi.nlm.nih.gov/)]
- 2. Mitochondria-targeting drug oligomycin blocked P-glycoprotein activity and triggered apoptosis in doxorubicin-resistant HepG2 cells - PubMed [[pubmed.ncbi.nlm.nih.gov](https://pubmed.ncbi.nlm.nih.gov/)]
- 3. Synergistic Antitumor Effect of Oligogalacturonides and Cisplatin on Human Lung Cancer A549 Cells [[mdpi.com](https://www.mdpi.com/)]
- 4. [researchgate.net](https://www.researchgate.net/) [[researchgate.net](https://www.researchgate.net/)]
- To cite this document: BenchChem. [Application Notes and Protocols for 44-Homooligomycin B in Combination Chemotherapy]. BenchChem, [2026]. [Online PDF]. Available at: [<https://www.benchchem.com/product/b15565327/docs#application-notes-and-protocols-for-44-homooligomycin-b-in-combination-chemotherapy>]

---

**Disclaimer & Data Validity:**

The information provided in this document is for Research Use Only (RUO) and is strictly not intended for diagnostic or therapeutic procedures. While BenchChem strives to provide accurate protocols, we make no warranties, express or implied, regarding the fitness of this product for every specific experimental setup.

**Technical Support:** The protocols provided are for reference purposes. Unsure if this reagent suits your experiment?

**Need Industrial/Bulk Grade?** [Request Custom Synthesis Quote](#)

# BenchChem

Our mission is to be the trusted global source of essential and advanced chemicals, empowering scientists and researchers to drive progress in science and industry.

## Contact

Address: 3281 E Guasti Rd  
Ontario, CA 91761, United States  
Phone: (601) 213-4426  
Email: [info@benchchem.com](mailto:info@benchchem.com)

[Contact our Ph.D. Support Team for a compatibility check](#)