

# Suramin Technical Support Center: Troubleshooting Guides & FAQs

**Author:** BenchChem Technical Support Team. **Date:** April 2026

## Compound of Interest

Compound Name:	Suramin
CAS No.:	129-46-4; 145-63-1
Cat. No.:	B15564017

[Get Quote](#)

This technical support center provides researchers, scientists, and drug development professionals with detailed information on the dose-dependent effects and therapeutic window of **suramin**. It includes troubleshooting guides, frequently asked questions, quantitative data summaries, and detailed experimental protocols to assist in the design and execution of experiments involving this complex molecule.

## Frequently Asked Questions (FAQs)

Q1: What is the primary mechanism of action of **suramin**?

A1: **Suramin** is a polysulfonated naphthylurea that acts as a broad-spectrum antagonist of P2 purinergic receptors, thereby inhibiting purinergic signaling pathways crucial for cellular functions like inflammation, immune response, and cell proliferation.<sup>[1]</sup> Additionally, it is known to inhibit the binding of various growth factors to their receptors, including Platelet-Derived Growth Factor (PDGF), Epidermal Growth Factor (EGF), Transforming Growth Factor-beta (TGF- $\beta$ ), and Fibroblast Growth Factors (FGFs).<sup>[1][2][3][4]</sup>

Q2: What is the therapeutic window for **suramin**?

A2: **Suramin** has a narrow therapeutic window, which necessitates careful dose monitoring to balance efficacy and toxicity.[5] In clinical settings for cancer treatment, therapeutic plasma concentrations are often targeted between 150 and 300 µg/mL.[5] Concentrations exceeding 350 µg/mL are associated with an increased risk of neurotoxicity and coagulopathy.[6]

Q3: What are the common toxicities associated with **suramin** administration?

A3: Common side effects of **suramin** include nausea, vomiting, diarrhea, and skin rashes.[1] More severe dose-limiting toxicities can include proteinuria, renal toxicity, peripheral neuropathy, fatigue, and anorexia.[6][7]

Q4: Is **suramin** stable in solution?

A4: **Suramin** at a concentration of 1 mg/mL is stable in common infusion fluids such as 0.9% NaCl, 5% dextrose, and lactated Ringer's injection for at least seven days when stored at 4°C in the dark or at 22°C protected from light.[2] However, solutions should ideally be used immediately after preparation as they can deteriorate on storage. It is important to note that some batches of **suramin** may contain impurities that appear brown in solution; only colorless solutions should be used for experiments.[8]

Q5: Can **suramin** interfere with common cell-based assays?

A5: Yes, as a polyanionic molecule, **suramin** has the potential to interfere with certain assays. For instance, in colorimetric assays like the MTT assay, it is crucial to include proper controls to account for any potential interaction of **suramin** with the assay reagents. Researchers should be aware of potential artifacts and consider alternative or complementary assays to validate their findings.[9][10][11]

## Troubleshooting Guides

Issue 1: High variability or unexpected results in cell viability assays (e.g., MTT, XTT).

- Possible Cause: Interference of **suramin** with the assay reagents. Polyanionic compounds can sometimes interact with the tetrazolium salts or formazan crystals.
- Troubleshooting Steps:

- Include a "drug-only" control: In a cell-free well, add your highest concentration of **suramin** to the assay medium and the viability reagent to check for any direct chemical reaction that might alter the absorbance reading.
- Visual inspection: Before adding the solubilizing agent in an MTT assay, visually inspect the wells under a microscope to confirm that the observed color change correlates with the number of viable cells.
- Use an alternative assay: Validate your results using a different viability assay that relies on a different principle, such as a resazurin-based assay or a direct cell counting method (e.g., trypan blue exclusion).[12]
- Serum concentration: Be aware that the protein content in the serum can affect **suramin's** activity. Ensure consistent serum concentrations across all experiments.[3]

Issue 2: Poor solubility or precipitation of **suramin** in cell culture medium.

- Possible Cause: **Suramin's** solubility can be dependent on the pH and composition of the medium. Some complex media components may interact with **suramin**.
- Troubleshooting Steps:
  - Prepare fresh stock solutions: Dissolve **suramin** powder in water or a suitable buffer like PBS immediately before use. Sigma-Aldrich recommends dissolving in water at 50 mg/ml.
  - pH adjustment: Check the pH of your final culture medium after adding **suramin**. Although **suramin** is generally soluble in aqueous solutions, extreme pH values should be avoided.
  - Avoid high concentrations in complex media: If high concentrations are required, consider preparing a concentrated stock in a simple, buffered saline solution and then diluting it into the final culture medium. Some amino acids in complex media can have poor solubility and might contribute to precipitation.[13][14]
  - Filtration: After dissolving **suramin** in your vehicle, filter-sterilize the solution using a 0.22 µm filter to remove any undissolved particles before adding it to your cell cultures.

Issue 3: Inconsistent results in in vivo animal studies.

- Possible Cause: Interpatient variability in pharmacokinetics is a known characteristic of **suramin**.<sup>[6]</sup>
- Troubleshooting Steps:
  - Dose calculation: Ensure accurate and consistent dosing based on the animal's body weight.
  - Route of administration: The route of administration (e.g., intravenous, intraperitoneal) can significantly impact the bioavailability and pharmacokinetics of **suramin**. Maintain consistency across all animals in a study group.
  - Monitor for toxicity: Closely monitor animals for signs of toxicity, such as weight loss, lethargy, or ruffled fur, as these can impact the experimental outcomes.
  - Plasma concentration monitoring: If feasible, consider measuring plasma **suramin** concentrations to correlate drug exposure with the observed effects.

## Quantitative Data on Suramin's Dose-Dependent Effects

### In Vitro Efficacy: IC50 Values

Cell Line	Cancer Type	Assay	IC50 (μM)	Notes
HeLa	Cervical Cancer	DNA synthesis inhibition	8 (for DNA polymerase α), 36 (for DNA polymerase δ)	Suramin is a more potent inhibitor of DNA polymerase α. [15]
Human Teratocarcinoma (NT2/D1, N2102ep)	Germ Cell Tumor	Monolayer growth inhibition	Dose-dependent inhibition at clinically achievable concentrations	Specific IC50 values not provided, but effective at concentrations used in patients. [16]
Human Lung Cancer Cell Lines	Lung Cancer	MTT assay	130 - 3715	High variability across different cell lines.[17]
Transitional Carcinoma Cell Lines (MBT2, T24, RT4, TCCSUP)	Bladder Cancer	Cell proliferation	~100 - 400 μg/mL (approx. 70 - 280 μM)	RT4 was the most sensitive cell line.[18]
Human Prostate Epithelial Cells (Normal, BPH, Cancerous)	Prostate Cancer	Cell proliferation	50 - 100	No significant difference in sensitivity between normal and cancerous cells.[19]
Vero E6	N/A (Kidney epithelial)	SARS-CoV-2 induced CPE reduction	EC50 of ~20	Demonstrates antiviral activity. [20]

## In Vivo Preclinical Dosing

Animal Model	Condition	Suramin Dose	Schedule	Key Findings
Mice with PC3 tumors	Prostate Cancer	10 mg/kg	Intravenously, twice weekly for 3 weeks	Enhanced the antitumor effect of doxorubicin without increasing toxicity.[21]
Mice with pancreatic cancer xenografts	Pancreatic Cancer	Not specified	Not specified	Significantly reduced tumor size and metastatic spread.[22]
DEN/CCl <sub>4</sub> -induced HCC model mice	Hepatocellular Carcinoma	10 mg/kg	Twice a week for 3 weeks	Enhanced the antitumor effect of 1,25(OH) <sub>2</sub> D <sub>3</sub> . [15]
Mice with lung metastases	Lung Cancer	10 mg/kg	Intravenously, twice weekly for 3 weeks	Enhanced the antitumor effect of paclitaxel.[23]

## Clinical Therapeutic Window & Dosing

Indication	Dose	Target Plasma Concentration	Key Toxicities
Advanced Cancer	1440 mg/m <sup>2</sup> (MTD)	Below 350 µg/mL	Fatigue, neuropathy, anorexia.[6]
Hormone-Refractory Prostate Cancer	Loading dose followed by weekly maintenance	150 - 300 µg/mL	Not specified in this study, but neurotoxicity is a known risk at higher concentrations.[5]
Autism Spectrum Disorder	10 mg/kg or 20 mg/kg	Not specified	Generally well-tolerated; mild to moderate adverse events. A non-monotonic dose response was observed, with the 10 mg/kg dose showing more improvement in some measures.[1][6]
Trypanosomiasis	100-200 mg (test dose), then 1 g	Not specified	Vomiting, urticaria, paresthesia, peripheral neuropathy, kidney damage.[16]

## Experimental Protocols

### MTT Cell Viability Assay

Objective: To assess the effect of **suramin** on cell viability and determine its IC<sub>50</sub> value.

Methodology:

- Cell Seeding: Seed cells in a 96-well plate at a predetermined optimal density and allow them to adhere overnight.

- **Compound Treatment:** Prepare serial dilutions of **suramin** in culture medium. Remove the old medium from the wells and add the **suramin**-containing medium. Include vehicle-only controls.
- **Incubation:** Incubate the plate for the desired treatment duration (e.g., 24, 48, or 72 hours) at 37°C in a humidified CO<sub>2</sub> incubator.
- **MTT Addition:** Add MTT solution (final concentration of 0.5 mg/mL) to each well and incubate for 3-4 hours at 37°C.[23]
- **Formazan Solubilization:** Carefully remove the MTT-containing medium and add a solubilizing agent (e.g., DMSO or a specialized solubilization buffer) to dissolve the purple formazan crystals.[23]
- **Absorbance Reading:** Measure the absorbance at a wavelength between 550 and 600 nm using a microplate reader.
- **Data Analysis:** Calculate the percentage of cell viability relative to the vehicle control and plot a dose-response curve to determine the IC<sub>50</sub> value.

## Colony Formation (Clonogenic) Assay

**Objective:** To evaluate the long-term effect of **suramin** on the ability of single cells to form colonies.

**Methodology:**

- **Cell Seeding:** Plate a low density of cells (e.g., 200-1000 cells per well in a 6-well plate) to allow for the formation of distinct colonies.
- **Treatment:** Treat the cells with various concentrations of **suramin** either before or after plating, depending on the experimental design.
- **Incubation:** Incubate the plates for 1-3 weeks, allowing sufficient time for colony formation.[9]  
[24]
- **Colony Fixation and Staining:**

- Carefully wash the wells with PBS.
- Fix the colonies with a solution like 6.0% (v/v) glutaraldehyde.
- Stain the fixed colonies with 0.5% (w/v) crystal violet.[24]
- Colony Counting: Count the number of colonies (typically defined as a cluster of  $\geq 50$  cells) in each well.
- Data Analysis: Calculate the plating efficiency and survival fraction for each treatment group compared to the control.

## [<sup>3</sup>H]-Thymidine Incorporation Assay

Objective: To measure the effect of **suramin** on DNA synthesis as an indicator of cell proliferation.

Methodology:

- Cell Culture and Treatment: Culture cells in a 96-well plate and treat them with different concentrations of **suramin** for a specified period.
- Radiolabeling: Add [<sup>3</sup>H]-thymidine to each well and incubate for a period that allows for its incorporation into newly synthesized DNA (typically 4-24 hours).[25]
- Cell Harvesting: Harvest the cells onto glass fiber filters using a cell harvester. This process lyses the cells and traps the DNA on the filter.
- Washing: Wash the filters to remove unincorporated [<sup>3</sup>H]-thymidine.
- Scintillation Counting: Place the filters in scintillation vials with a scintillation cocktail and measure the radioactivity using a scintillation counter.
- Data Analysis: The amount of radioactivity is proportional to the rate of DNA synthesis. Compare the counts per minute (CPM) of treated samples to the control to determine the inhibitory effect of **suramin** on cell proliferation.[26]

# Signaling Pathway and Experimental Workflow Diagrams

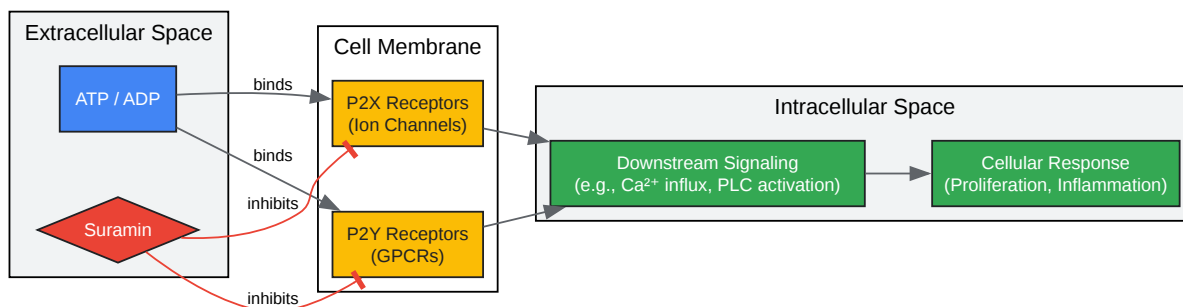

[Click to download full resolution via product page](#)

Caption: **Suramin's** inhibition of purinergic signaling.

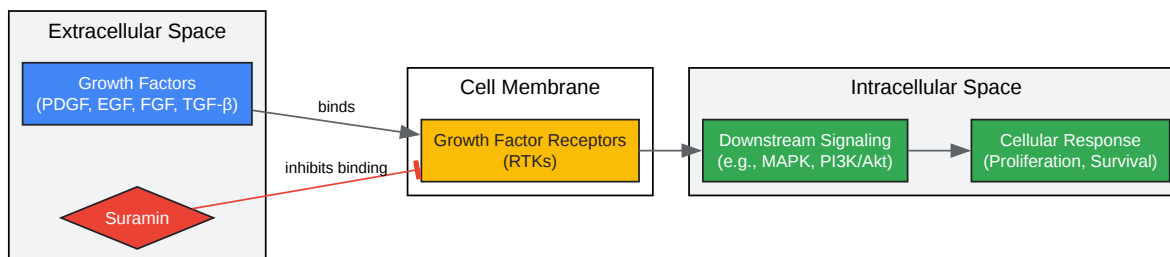

[Click to download full resolution via product page](#)

Caption: **Suramin's** inhibition of growth factor signaling.

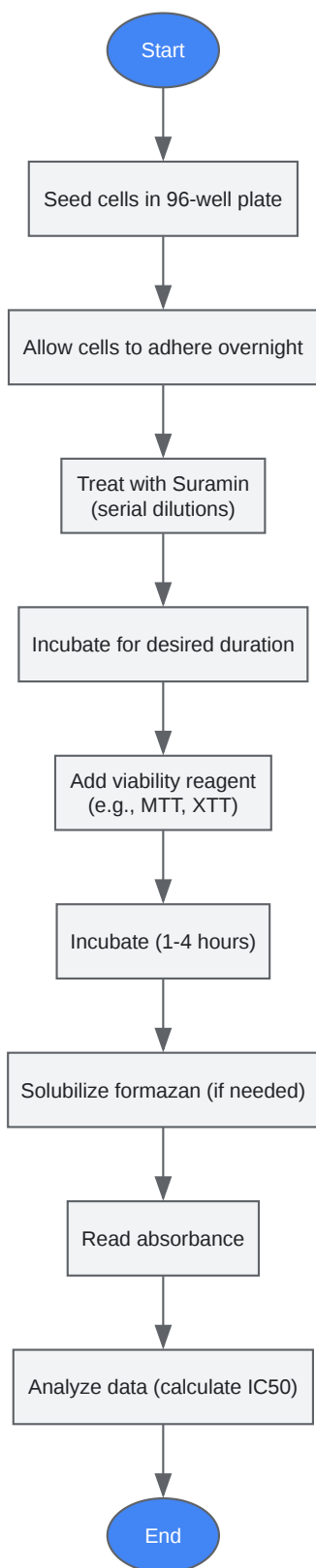

[Click to download full resolution via product page](#)

Caption: General workflow for a cell viability assay with **suramin**.

### Need Custom Synthesis?

BenchChem offers custom synthesis for rare earth carbides and specific isotopic labeling.

Email: [info@benchchem.com](mailto:info@benchchem.com) or [Request Quote Online](#).

## References

- 1. Randomized clinical trial of low dose suramin intravenous infusions for treatment of autism spectrum disorder - PMC [[pmc.ncbi.nlm.nih.gov](https://pubmed.ncbi.nlm.nih.gov)]
- 2. Chemical stability of suramin in commonly used infusion fluids - PubMed [[pubmed.ncbi.nlm.nih.gov](https://pubmed.ncbi.nlm.nih.gov)]
- 3. Effects of suramin on in vitro growth of fresh human tumors - PubMed [[pubmed.ncbi.nlm.nih.gov](https://pubmed.ncbi.nlm.nih.gov)]
- 4. Synthesis of Novel Suramin Analogs With Anti-Proliferative Activity via FGF1 and FGFRD2 Blockade - PMC [[pmc.ncbi.nlm.nih.gov](https://pubmed.ncbi.nlm.nih.gov)]
- 5. Suramin: rapid loading and weekly maintenance regimens for cancer patients - PubMed [[pubmed.ncbi.nlm.nih.gov](https://pubmed.ncbi.nlm.nih.gov)]
- 6. [researchgate.net](https://www.researchgate.net) [[researchgate.net](https://www.researchgate.net)]
- 7. [mayoclinic.elsevierpure.com](https://www.mayoclinic.com/elsevierpure.com) [[mayoclinic.elsevierpure.com](https://www.mayoclinic.com/elsevierpure.com)]
- 8. Suppression of cell membrane permeability by suramin: involvement of its inhibitory actions on connexin 43 hemichannels - PMC [[pmc.ncbi.nlm.nih.gov](https://pubmed.ncbi.nlm.nih.gov)]
- 9. Clonogenic Assay - Creative Bioarray - Creative Bioarray | Creative Bioarray [[creative-bioarray.com](https://www.creative-bioarray.com)]
- 10. Interference of imferon in colorimetric assays for iron - PubMed [[pubmed.ncbi.nlm.nih.gov](https://pubmed.ncbi.nlm.nih.gov)]
- 11. [longdom.org](https://www.longdom.org) [[longdom.org](https://www.longdom.org)]
- 12. Cell Viability Assays - Assay Guidance Manual - NCBI Bookshelf [[ncbi.nlm.nih.gov](https://pubmed.ncbi.nlm.nih.gov)]
- 13. WO2016091350A1 - Process for improving the solubility of cell culture media - Google Patents [[patents.google.com](https://patents.google.com)]
- 14. Optimizing the stability and solubility of cell culture media ingredients - Evonik Industries [[healthcare.evonik.com](https://www.healthcare.evonik.com)]
- 15. Suramin affects DNA synthesis in HeLa cells by inhibition of DNA polymerases - PubMed [[pubmed.ncbi.nlm.nih.gov](https://pubmed.ncbi.nlm.nih.gov)]

- 16. Suramin for germ cell tumors. In vitro growth inhibition and results of a phase II trial - PubMed [pubmed.ncbi.nlm.nih.gov]
- 17. texaschildrens.org [texaschildrens.org]
- 18. Suramin inhibits proliferation and DNA synthesis in transitional carcinoma cell lines - PubMed [pubmed.ncbi.nlm.nih.gov]
- 19. In vitro effect of suramin on lung tumour cells - PubMed [pubmed.ncbi.nlm.nih.gov]
- 20. Suramin Inhibits SARS-CoV-2 Infection in Cell Culture by Interfering with Early Steps of the Replication Cycle - PMC [pmc.ncbi.nlm.nih.gov]
- 21. MTT assay protocol | Abcam [abcam.com]
- 22. Suramin analogs inhibit human angiogenesis in vitro - PubMed [pubmed.ncbi.nlm.nih.gov]
- 23. MTT Assay Protocol for Cell Viability and Proliferation [merckmillipore.com]
- 24. Clonogenic assay of cells in vitro - PubMed [pubmed.ncbi.nlm.nih.gov]
- 25. cytologicsbio.com [cytologicsbio.com]
- 26. Drug design and testing: profiling of antiproliferative agents for cancer therapy using a cell-based methyl-[3H]-thymidine incorporation assay - PubMed [pubmed.ncbi.nlm.nih.gov]
- To cite this document: BenchChem. [Suramin Technical Support Center: Troubleshooting Guides & FAQs]. BenchChem, [2026]. [Online PDF]. Available at: [https://www.benchchem.com/product/b15564017/docs#suramin-technical-support-center-troubleshooting-guides-faqs]

---

### Disclaimer & Data Validity:

The information provided in this document is for Research Use Only (RUO) and is strictly not intended for diagnostic or therapeutic procedures. While BenchChem strives to provide accurate protocols, we make no warranties, express or implied, regarding the fitness of this product for every specific experimental setup.

**Technical Support:** The protocols provided are for reference purposes. Unsure if this reagent suits your experiment?

**Need Industrial/Bulk Grade?** [Request Custom Synthesis Quote](#)

# BenchChem

Our mission is to be the trusted global source of essential and advanced chemicals, empowering scientists and researchers to drive progress in science and industry.

## Contact

Address: 3281 E Guasti Rd

Ontario, CA 91761, United States

Phone: (601) 213-4426

Email: [info@benchchem.com](mailto:info@benchchem.com)

[Contact our Ph.D. Support Team for a compatibility check](#)