

Mitigating matrix effects in LC-MS/MS analysis of Fidaxomicin

Author: BenchChem Technical Support Team. **Date:** April 2026

Compound of Interest

Compound Name: *Fidaxomicin (Standard)*

Cat. No.: *B15564435*

[Get Quote](#)

Technical Support Center: Fidaxomicin LC-MS/MS Analysis

This guide provides troubleshooting advice and answers to frequently asked questions regarding the mitigation of matrix effects in the Liquid Chromatography with tandem mass spectrometry (LC-MS/MS) analysis of Fidaxomicin and its primary metabolite, OP-1118.

Frequently Asked Questions (FAQs)

Q1: What are matrix effects and how do they impact Fidaxomicin analysis?

A: Matrix effects are the alteration of ionization efficiency for a target analyte by the presence of co-eluting, undetected components in the sample matrix.^{[1][2]} In the analysis of Fidaxomicin from biological matrices like plasma, endogenous components such as phospholipids, salts, and proteins can co-extract with the analyte.^[1] During LC-MS/MS analysis, these components can compete with Fidaxomicin for ionization in the mass spectrometer's source, typically leading to a reduction in signal intensity, a phenomenon known as ion suppression.^{[2][3]} Less

commonly, an enhancement of the signal can occur. This interference can compromise the accuracy, precision, and sensitivity of the assay, leading to unreliable quantitative results.[4][5]

Q2: How can I detect and quantify matrix effects for my Fidaxomicin assay?

A: There are two primary methods to assess matrix effects:

- **Qualitative Assessment (Post-Column Infusion):** This method helps identify at which points in the chromatogram ion suppression or enhancement occurs.[4][6] A standard solution of Fidaxomicin is continuously infused into the mass spectrometer after the analytical column. A blank, extracted matrix sample is then injected. Any dip or rise in the constant analyte signal baseline indicates a region of ion suppression or enhancement caused by eluting matrix components.[4][6]
- **Quantitative Assessment (Post-Extraction Spike):** This is the standard method for quantifying the extent of matrix effects.[1] The response of an analyte spiked into a blank matrix extract (post-extraction) is compared to the response of the analyte in a neat (pure) solvent at the same concentration. The comparison is expressed as the Matrix Factor (MF).[1][7]

The Matrix Factor (MF) is calculated using the following formula:

$$\text{MF} = (\text{Peak Area of Analyte in Post-Extracted Matrix}) / (\text{Peak Area of Analyte in Neat Solution})$$

- An MF value of < 1 indicates ion suppression.
- An MF value of > 1 indicates ion enhancement.
- An MF value of = 1 indicates no significant matrix effect.

For robust methods, the coefficient of variation (%CV) of the internal standard-normalized matrix factor should be less than 15%.[7]

Q3: Which sample preparation technique is most effective for reducing matrix effects in plasma analysis of Fidaxomicin?

A: The choice of sample preparation is critical and involves a trade-off between cleanliness, recovery, and throughput. While no single study directly compares all methods for Fidaxomicin, available data and general principles suggest the following:

- Liquid-Liquid Extraction (LLE): This is a highly effective method for reducing matrix effects in Fidaxomicin analysis.[7] It efficiently removes endogenous matrix components, leading to cleaner extracts. A validated method using LLE has demonstrated good recovery and minimal matrix effects for Fidaxomicin and its metabolite.[7]
- Protein Precipitation (PPT) followed by Solid-Phase Extraction (SPE): This two-step approach was used in clinical trials for Fidaxomicin analysis.[8] PPT first removes the bulk of proteins, and the subsequent SPE step provides further cleanup, targeting more specific interferences. This combination is generally more effective than PPT alone.
- Protein Precipitation (PPT) alone: While being the simplest and fastest technique, PPT is often the least effective at removing matrix components like phospholipids, which are a major cause of ion suppression.[5] This method may be suitable for less stringent assay requirements but is more susceptible to matrix effects.

The diagram below illustrates the general trade-offs between these common extraction techniques.

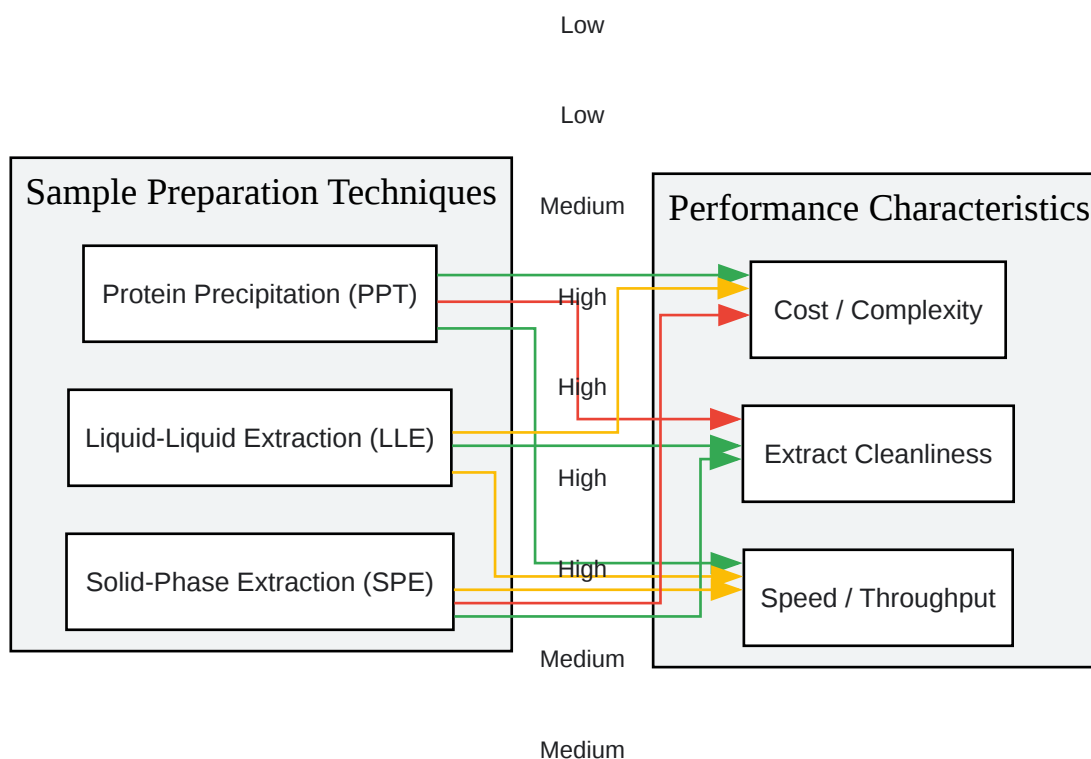

[Click to download full resolution via product page](#)

Caption: Comparison of common sample preparation techniques.

Q4: How can chromatographic conditions be optimized to minimize matrix effects?

A: Chromatographic separation is a powerful tool to resolve Fidaxomicin from interfering matrix components.[2] Key strategies include:

- **Column Chemistry:** Utilize columns with different selectivities (e.g., C18, Phenyl-Hexyl) to alter the elution profile of interferences relative to the analyte. An XSelect CSH C18 column has been successfully used for Fidaxomicin analysis.[7]
- **Gradient Optimization:** Employing a rapid gradient elution can help to approximate the retention times of Fidaxomicin and its internal standard, which is crucial for accurate quantification, especially when the internal standard has different polarity.[7] Extending the gradient can also provide better separation from late-eluting matrix components.

- **Mobile Phase Modifiers:** Adjusting the pH or using different additives (e.g., ammonium formate, formic acid) can change the retention and peak shape of both Fidaxomicin and matrix components, improving resolution.
- **UHPLC vs. HPLC:** Ultra-High-Performance Liquid Chromatography (UHPLC) systems provide narrower and sharper peaks due to higher resolution.[9] This reduces the likelihood of analytes co-eluting with interferences, thereby minimizing matrix effects compared to traditional HPLC.[9]

Troubleshooting Guide

This section addresses common issues encountered during the LC-MS/MS analysis of Fidaxomicin.

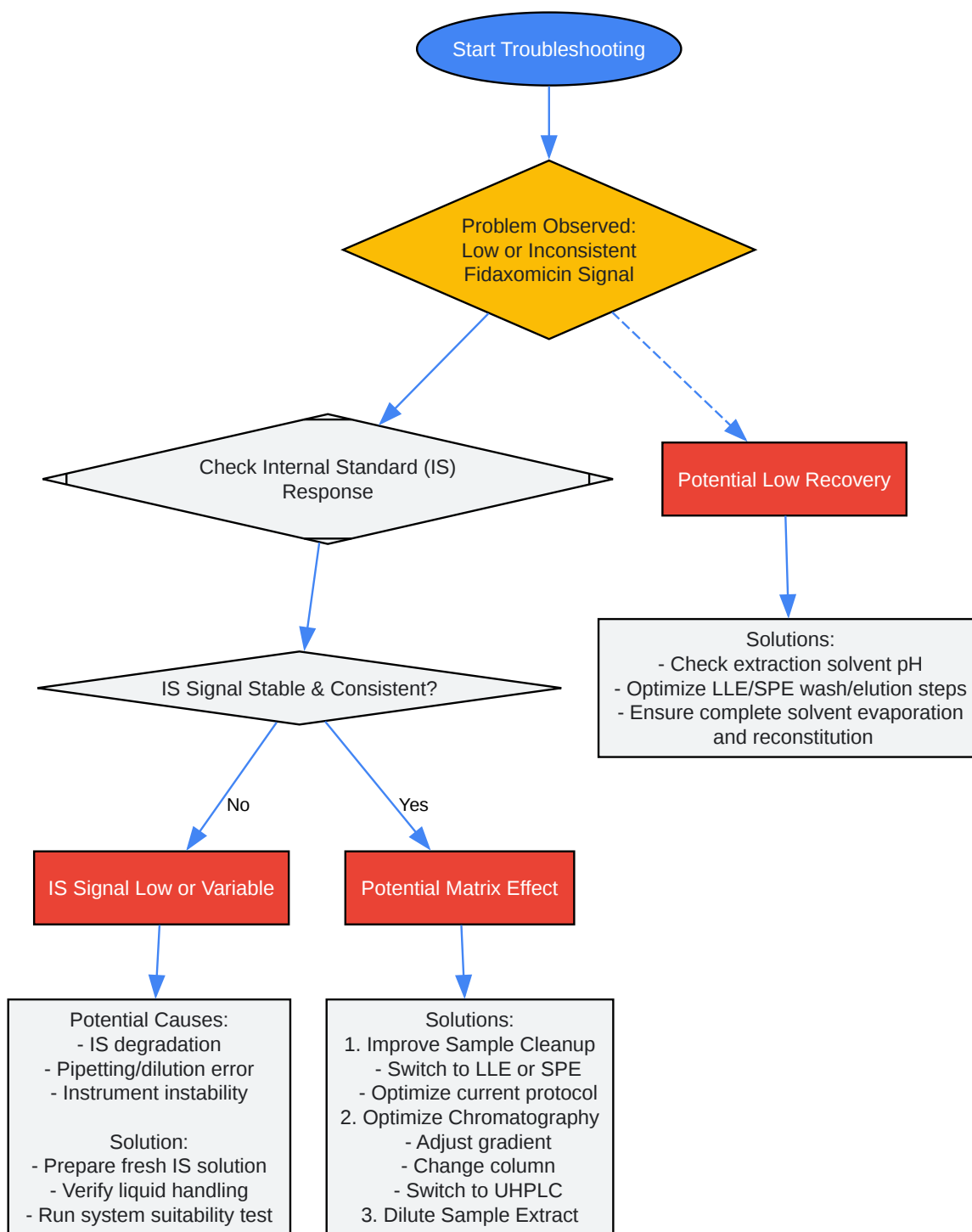

[Click to download full resolution via product page](#)

Caption: Troubleshooting workflow for low Fidaxomicin signal.

Issue 1: Low Analyte Response / Signal Suppression

- Symptom: The peak area for Fidaxomicin is significantly lower than expected in matrix samples compared to neat standards, even when the internal standard (IS) appears stable.
- Potential Cause: Ion suppression due to co-eluting endogenous matrix components.
- Troubleshooting Steps:
 - Confirm Matrix Effect: Perform a post-column infusion experiment to visualize the suppression zone. Quantify the effect using the post-extraction spike method.
 - Improve Sample Preparation: If currently using PPT, switch to a more rigorous method like LLE or SPE. The detailed LLE protocol in the next section is a validated starting point.
 - Optimize Chromatography: Modify the LC gradient to better separate Fidaxomicin from the suppression zone identified in the post-column infusion experiment.
 - Sample Dilution: Diluting the final extract can sometimes reduce the concentration of interfering components below a level where they cause significant suppression.

Issue 2: High Variability in Results (Poor Precision)

- Symptom: Replicate injections of the same sample or different samples from the same batch show high %RSD.
- Potential Cause: Inconsistent matrix effects between samples or inconsistent sample preparation (low recovery).
- Troubleshooting Steps:
 - Evaluate Internal Standard Performance: Ensure you are using a stable isotope-labeled (SIL) internal standard (e.g., Fidaxomicin-d7) whenever possible.^[7] A SIL IS co-elutes and experiences the same matrix effects as the analyte, effectively compensating for variability. If a SIL IS is not available for a metabolite (like OP-1118), optimizing chromatography to ensure it elutes in a clean region is critical.^[7]
 - Review Sample Preparation: Inconsistent recovery during extraction is a common source of variability. Ensure precise and reproducible execution of each step (pipetting, vortexing,

evaporation).

- Check for Contamination: Carryover from a previous high-concentration sample can cause variability. Run blank injections between samples to check for carryover.

Issue 3: Low Analyte Recovery

- Symptom: The overall signal for both the analyte and internal standard is low, and the calculated recovery is below acceptable limits (e.g., <70%).
- Potential Cause: Suboptimal extraction conditions leading to loss of the analyte during sample preparation.
- Troubleshooting Steps:
 - LLE Optimization: Ensure the pH of the aqueous phase and the choice of organic solvent are optimal for Fidaxomicin's chemical properties. Ensure phase separation is complete before aspirating the organic layer.
 - SPE Optimization: Review the conditioning, loading, washing, and elution steps. The wash step may be too harsh (eluting the analyte) or the elution solvent may be too weak (failing to recover the analyte).
 - Evaporation/Reconstitution: Ensure the extracted solvent is completely evaporated before reconstitution. The reconstitution solvent must be strong enough to fully dissolve the dried residue. Incomplete reconstitution is a common cause of low recovery.

Quantitative Data Summary

The following table summarizes the performance of a validated Liquid-Liquid Extraction (LLE) method for the analysis of Fidaxomicin and its metabolite OP-1118 in human plasma.[7]

Analyte	QC Level	Extraction Recovery (%)	IS-Normalized Matrix Factor (%)	RSD (%) of Matrix Factor
Fidaxomicin	Low (LQC)	66.9	96.8	6.1
	Medium (MQC)	73.0	-	-
	High (HQC)	72.9	100.7	1.9
OP-1118	Low (LQC)	61.0	78.1	3.0
	Medium (MQC)	62.2	-	-
	High (HQC)	64.5	68.4	1.4
Fidaxomicin-d7 (IS)	-	77.8	-	-

Data sourced from patent CN112816584A.[7] The results indicate that the LLE method provides good extraction recovery and effectively mitigates matrix effects, as shown by the IS-Normalized Matrix Factor values close to 100% with low RSD.

Experimental Protocols

Protocol 1: Liquid-Liquid Extraction (LLE) for Fidaxomicin in Plasma

This protocol is adapted from a validated bioanalytical method.[7]

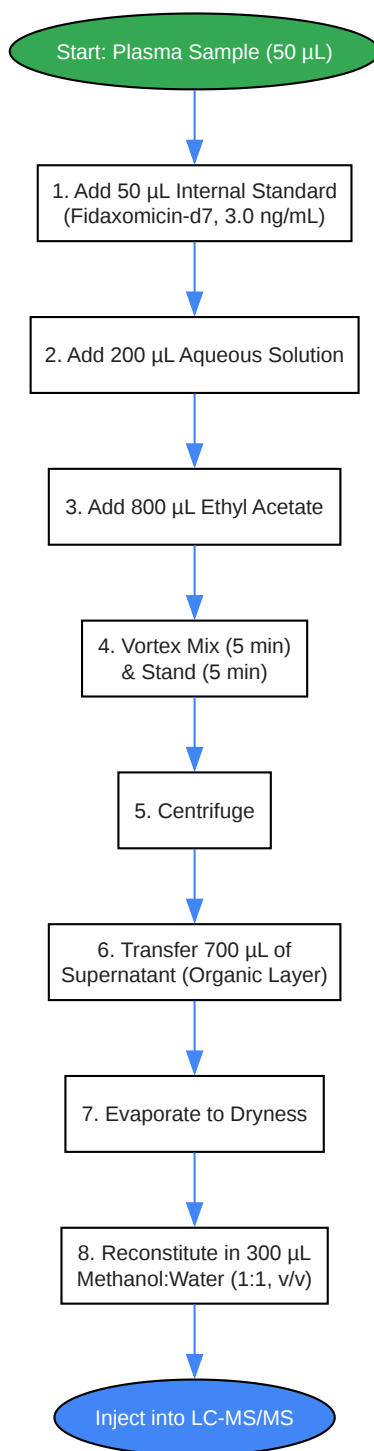

[Click to download full resolution via product page](#)

Caption: Workflow for Liquid-Liquid Extraction (LLE) of Fidaxomicin.

Procedure:

- Pipette 50.0 μL of plasma sample into a clean microcentrifuge tube.
- Add 50.0 μL of the internal standard working solution (e.g., 3.00 ng/mL Fidaxomicin-d7).
- Add 200 μL of deionized water.
- Add 800 μL of ethyl acetate.
- Vortex the mixture for 5 minutes to ensure thorough extraction, then let it stand for 5 minutes to allow for phase separation.
- Centrifuge the sample to achieve a clean separation of the layers.
- Carefully aspirate 700 μL of the upper organic layer (ethyl acetate) and transfer it to a new tube.
- Evaporate the solvent to complete dryness under a gentle stream of nitrogen.
- Reconstitute the dried residue in 300 μL of a methanol-water (1:1, v/v) solution. Vortex to mix.
- The sample is now ready for injection into the LC-MS/MS system.

Protocol 2: General Protein Precipitation (PPT) followed by Solid-Phase Extraction (SPE)

This is a general protocol based on methods used in clinical studies for Fidaxomicin.[8] Specific SPE cartridge types (e.g., Oasis HLB) and solvent volumes may require optimization.

Procedure:

Part A: Protein Precipitation

- Pipette 200 μL of plasma into a microcentrifuge tube.
- Add 25 μL of internal standard working solution.
- Add 600 μL of cold acetonitrile (a 3:1 ratio of solvent to plasma) to precipitate the proteins.

- Vortex the mixture vigorously for 1-2 minutes.
- Centrifuge at high speed (e.g., >10,000 x g) for 10 minutes to pellet the precipitated proteins.
- Carefully collect the supernatant for the SPE cleanup.

Part B: Solid-Phase Extraction (SPE)

- Condition: Condition the SPE cartridge (e.g., a polymeric reversed-phase sorbent) with 1 mL of methanol, followed by 1 mL of water.
- Load: Load the supernatant from the PPT step onto the conditioned SPE cartridge.
- Wash: Wash the cartridge with a weak organic solvent (e.g., 1 mL of 5% methanol in water) to remove polar interferences.
- Elute: Elute Fidaxomicin and its metabolite from the cartridge using a strong organic solvent (e.g., 1 mL of methanol or acetonitrile).
- Evaporate & Reconstitute: Evaporate the eluate to dryness and reconstitute in an appropriate volume of mobile phase for LC-MS/MS analysis.

Need Custom Synthesis?

BenchChem offers custom synthesis for rare earth carbides and specific isotopic labeling.

Email: info@benchchem.com or [Request Quote Online](#).

References

- [1. sigmaaldrich.com](https://www.sigmaaldrich.com) [[sigmaaldrich.com](https://www.sigmaaldrich.com)]
- [2. researchgate.net](https://www.researchgate.net) [[researchgate.net](https://www.researchgate.net)]
- [3. Protein preparation for LC-MS/MS analysis](https://www.protocols.io) [[protocols.io](https://www.protocols.io)]
- [4. TROUBLE SHOOTING DURING BIOANALYTICAL ESTIMATION OF DRUG AND METABOLITES USING LC-MS/MS: A REVIEW - PMC](https://pubmed.ncbi.nlm.nih.gov/) [[pmc.ncbi.nlm.nih.gov](https://pubmed.ncbi.nlm.nih.gov/)]
- [5. SPE Method Development | Thermo Fisher Scientific - HK](https://www.thermofisher.com) [[thermofisher.com](https://www.thermofisher.com)]

- [6. chromatographyonline.com \[chromatographyonline.com\]](https://www.chromatographyonline.com)
- [7. CN112816584A - Bioanalysis method of fidaxomicin and metabolite OP-1118 thereof in human plasma - Google Patents \[patents.google.com\]](#)
- [8. Fidaxomicin Attains High Fecal Concentrations With Minimal Plasma Concentrations Following Oral Administration in Patients With Clostridium difficile Infection - PMC \[pmc.ncbi.nlm.nih.gov\]](#)
- [9. Comparison of matrix effects in HPLC-MS/MS and UPLC-MS/MS analysis of nine basic pharmaceuticals in surface waters - PubMed \[pubmed.ncbi.nlm.nih.gov\]](#)
- To cite this document: BenchChem. [Mitigating matrix effects in LC-MS/MS analysis of Fidaxomicin]. BenchChem, [2026]. [Online PDF]. Available at: [\[https://www.benchchem.com/product/b15564435/docs#mitigating-matrix-effects-in-lc-ms-ms-analysis-of-fidaxomicin\]](https://www.benchchem.com/product/b15564435/docs#mitigating-matrix-effects-in-lc-ms-ms-analysis-of-fidaxomicin)

Disclaimer & Data Validity:

The information provided in this document is for Research Use Only (RUO) and is strictly not intended for diagnostic or therapeutic procedures. While BenchChem strives to provide accurate protocols, we make no warranties, express or implied, regarding the fitness of this product for every specific experimental setup.

Technical Support: The protocols provided are for reference purposes. Unsure if this reagent suits your experiment?

Need Industrial/Bulk Grade? [Request Custom Synthesis Quote](#)

BenchChem

Our mission is to be the trusted global source of essential and advanced chemicals, empowering scientists and researchers to drive progress in science and industry.

Contact

Address: 3281 E Guasti Rd
Ontario, CA 91761, United States
Phone: (601) 213-4426
Email: info@benchchem.com

Contact our Ph.D. Support Team for a compatibility check