

Fidaxomicin's Antibacterial Spectrum: A Technical Guide

Author: BenchChem Technical Support Team. **Date:** April 2026

Compound of Interest

Compound Name: *Fidaxomicin (Standard)*

Cat. No.: *B15564435*

[Get Quote](#)

For Researchers, Scientists, and Drug Development Professionals

Introduction

Fidaxomicin, a first-in-class macrocyclic antibiotic, represents a significant therapeutic advance in the treatment of *Clostridioides difficile* infection (CDI). Its targeted spectrum of activity, potent bactericidal action against *C. difficile*, and minimal disruption to the normal gut microbiota distinguish it from broad-spectrum antibiotics traditionally used for CDI. This technical guide provides a comprehensive overview of fidaxomicin's antibacterial spectrum, detailing its mechanism of action, in vitro activity, and the standardized methodologies for its evaluation.

Mechanism of Action

Fidaxomicin exerts its bactericidal effect by inhibiting bacterial RNA polymerase (RNAP), a crucial enzyme for transcription.^{[1][2]} Unlike rifamycins, which also target RNAP, fidaxomicin acts at an earlier step in the transcription initiation process.^{[1][2]} It binds to the DNA template-RNA polymerase complex, preventing the initial separation of DNA strands required for messenger RNA (mRNA) synthesis.^[1] This inhibition is mediated through interactions with the switch regions of the RNAP, effectively trapping the enzyme in an open-clamp conformation.

The specificity of fidaxomicin is attributed to differences in the σ subunit of the RNA polymerase among various bacterial species.

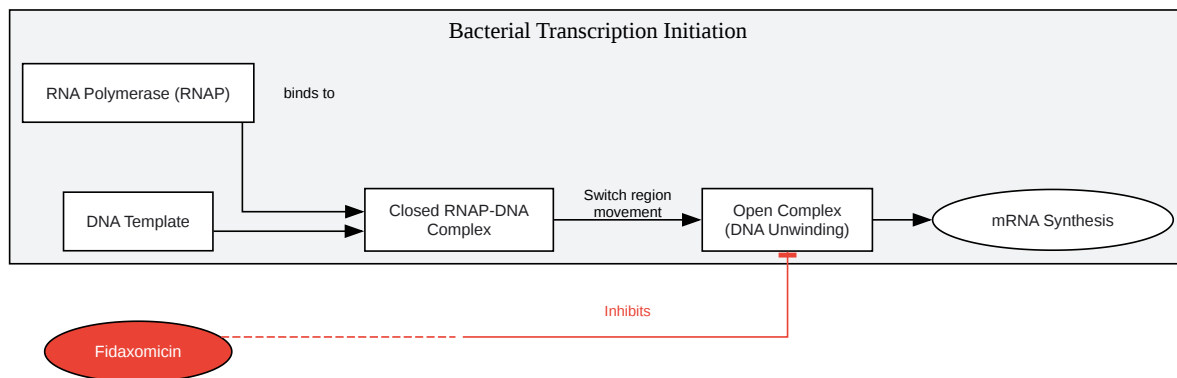

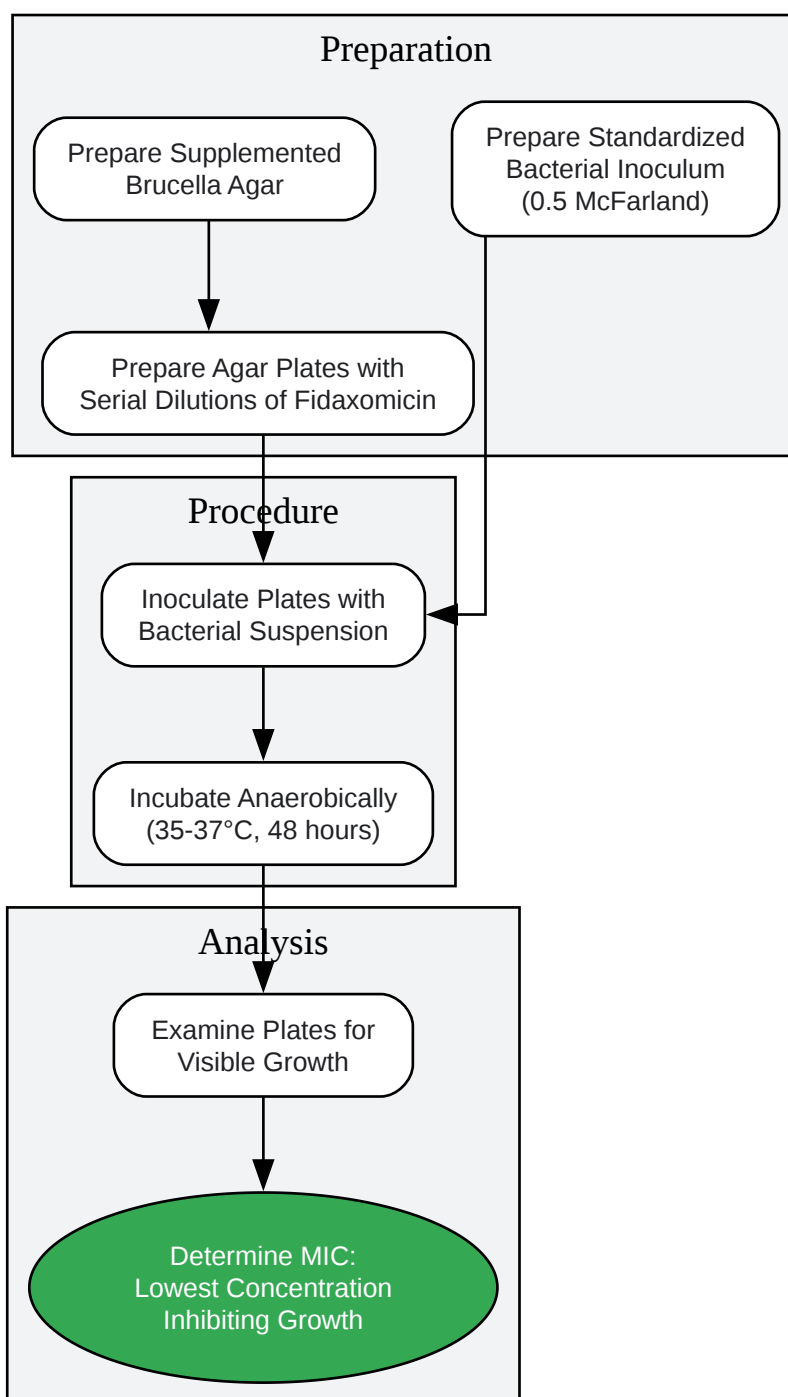

[Click to download full resolution via product page](#)

Need Custom Synthesis?

BenchChem offers custom synthesis for rare earth carbides and specific isotopic labeling.

Email: info@benchchem.com or [Request Quote Online](#).

References

- [1. researchgate.net \[researchgate.net\]](#)
- [2. MIC Determination By Microtitre Broth Dilution Method - Hancock Lab \[cmdr.ubc.ca\]](#)
- To cite this document: BenchChem. [Fidaxomicin's Antibacterial Spectrum: A Technical Guide]. BenchChem, [2026]. [Online PDF]. Available at: [\[https://www.benchchem.com/product/b15564435/docs#fidaxomicin-s-antibacterial-spectrum-a-technical-guide\]](https://www.benchchem.com/product/b15564435/docs#fidaxomicin-s-antibacterial-spectrum-a-technical-guide)

Disclaimer & Data Validity:

The information provided in this document is for Research Use Only (RUO) and is strictly not intended for diagnostic or therapeutic procedures. While BenchChem strives to provide accurate protocols, we make no warranties, express or implied, regarding the fitness of this product for every specific experimental setup.

Technical Support: The protocols provided are for reference purposes. Unsure if this reagent suits your experiment?

Need Industrial/Bulk Grade? [Request Custom Synthesis Quote](#)

BenchChem

Our mission is to be the trusted global source of essential and advanced chemicals, empowering scientists and researchers to drive progress in science and industry.

Contact

Address: 3281 E Guasti Rd
Ontario, CA 91761, United States
Phone: (601) 213-4426
Email: info@benchchem.com

[Contact our Ph.D. Support Team for a compatibility check](#)

