

# Benchmarking EV-A71-IN-2: A Comparative Guide to Antiviral Performance

**Author:** BenchChem Technical Support Team. **Date:** April 2026

## Compound of Interest

Compound Name: EV-A71-IN-2

Cat. No.: B15564916

[Get Quote](#)

For Researchers, Scientists, and Drug Development Professionals

This guide provides a comprehensive performance comparison of the novel anti-enterovirus compound, **EV-A71-IN-2**, against established reference compounds for Enterovirus A71 (EV-A71). The data presented is intended to aid researchers in evaluating the potential of **EV-A71-IN-2** for further investigation and development.

## Performance Data Summary

The antiviral activity and cytotoxicity of **EV-A71-IN-2** and selected reference compounds are summarized in the tables below. It is important to note that antiviral potency can vary depending on the specific EV-A71 strain, the cell line used for testing, and the experimental protocol. The data presented here is compiled from various studies and should be considered in the context of the specified experimental conditions.

Table 1: In Vitro Antiviral Activity and Cytotoxicity of **EV-A71-IN-2**

Compound	Virus Strain	Cell Line	EC50 (µM)	CC50 (µM)	Selectivity Index (SI)
EV-A71-IN-2	Not Specified	MRC-5	0.29[1]	Not Reported	Not Reported
EV-A71-IN-2	Not Specified	RD	1.66[1]	Not Reported	Not Reported

Table 2: In Vitro Antiviral Activity and Cytotoxicity of Reference Compounds

Compound	Target	Virus Strain(s)	Cell Line	EC50 (µM)	CC50 (µM)	Selectivity Index (SI)
Pleconaril	VP1 Capsid Protein	Various EV-A71 strains	Various	>262 (in one study) [2]	Not Reported	Not Reported
Rupintrivir (AG7088)	3C Protease	EV71 (isolate BJ/CHN/2008)	RD	~0.001[3] [4]	>100	>100,000
Enviroxime	3A Protein / PI4KB	EV-A71	RD	0.051 - 0.312[5]	36.4[6]	>116 - 713
Vapendavir	VP1 Capsid Protein	21 EV-A71 strains	Various	0.361 - 0.957[2]	Not Reported	Not Reported
Pirodavir	VP1 Capsid Protein	EV-A71	Various	0.074 - 5.746[5]	Not Reported	Not Reported

Note: The EC50, CC50, and SI values for reference compounds are presented as a range based on available literature, reflecting the variability across different studies and experimental setups.

## Experimental Protocols

The following are detailed methodologies for key experiments typically used to evaluate the antiviral efficacy and cytotoxicity of compounds against EV-A71.

## Cell Viability and Cytotoxicity Assay (MTT Assay)

The 3-(4,5-dimethylthiazol-2-yl)-2,5-diphenyltetrazolium bromide (MTT) assay is a colorimetric method used to assess cell metabolic activity, which serves as an indicator of cell viability and cytotoxicity.<sup>[7][8][9][10]</sup>

Principle: Metabolically active cells possess NAD(P)H-dependent oxidoreductase enzymes that reduce the yellow, water-soluble MTT to a purple, insoluble formazan.<sup>[7][9]</sup> The amount of formazan produced is directly proportional to the number of viable cells.

Procedure:

- **Cell Seeding:** Seed cells in a 96-well plate at a density of  $1-2 \times 10^4$  cells per well and incubate overnight to allow for cell attachment.
- **Compound Treatment:** Add serial dilutions of the test compound to the wells and incubate for a period that corresponds to the duration of the antiviral assay (typically 48-72 hours).
- **MTT Addition:** After the incubation period, add 10-20  $\mu\text{L}$  of MTT solution (5 mg/mL in PBS) to each well and incubate for 4 hours at 37°C.<sup>[7]</sup>
- **Formazan Solubilization:** Carefully remove the culture medium and add 100-150  $\mu\text{L}$  of a solubilization solution (e.g., DMSO, isopropanol with 0.04 N HCl, or a specialized SDS-HCl solution) to dissolve the formazan crystals.<sup>[7][10]</sup>
- **Absorbance Measurement:** Shake the plate for 15 minutes to ensure complete dissolution and measure the absorbance at a wavelength of 570 nm using a microplate reader. A reference wavelength of 630 nm can be used to subtract background absorbance.
- **Data Analysis:** The 50% cytotoxic concentration (CC50) is calculated as the compound concentration that reduces cell viability by 50% compared to untreated control cells.

## Antiviral Activity Assay (Plaque Reduction Assay)

The plaque reduction assay is a functional assay that determines the ability of an antiviral compound to inhibit the lytic cycle of a virus.[\[11\]](#)[\[12\]](#)[\[13\]](#)[\[14\]](#)

Principle: Infectious virus particles create localized areas of cell death or cytopathic effect (CPE) in a monolayer of host cells. These areas, called plaques, can be visualized and counted. An effective antiviral agent will reduce the number of plaques in a dose-dependent manner.

Procedure:

- **Cell Seeding:** Seed susceptible cells (e.g., RD or Vero cells) in 24- or 12-well plates and grow to a confluent monolayer.[\[11\]](#)[\[15\]](#)
- **Virus and Compound Preparation:** Prepare serial dilutions of the test compound. In separate tubes, mix the compound dilutions with a known amount of EV-A71 (typically 50-100 plaque-forming units, PFU).
- **Infection:** Remove the growth medium from the cell monolayers and infect the cells with the virus-compound mixture. Incubate for 1-2 hours at 37°C to allow for virus adsorption.[\[11\]](#)[\[15\]](#)
- **Overlay:** After the adsorption period, remove the inoculum and overlay the cell monolayer with a semi-solid medium (e.g., containing carboxymethylcellulose or Avicel) mixed with the corresponding concentration of the test compound. This restricts the spread of progeny virus to adjacent cells.[\[11\]](#)
- **Incubation:** Incubate the plates at 37°C in a CO<sub>2</sub> incubator for 3-7 days until plaques are visible.
- **Plaque Visualization:** Fix the cells with a solution like 4% formaldehyde and then stain with a dye such as 0.5% crystal violet. Plaques will appear as clear zones against a stained background of viable cells.[\[11\]](#)
- **Data Analysis:** Count the number of plaques in each well. The 50% effective concentration (EC<sub>50</sub>) is determined as the compound concentration that reduces the number of plaques by 50% compared to the virus-only control.

## Visualizing Mechanisms and Workflows

The following diagrams illustrate the EV-A71 replication cycle, the points of intervention for different classes of antiviral compounds, and a typical experimental workflow for antiviral screening.

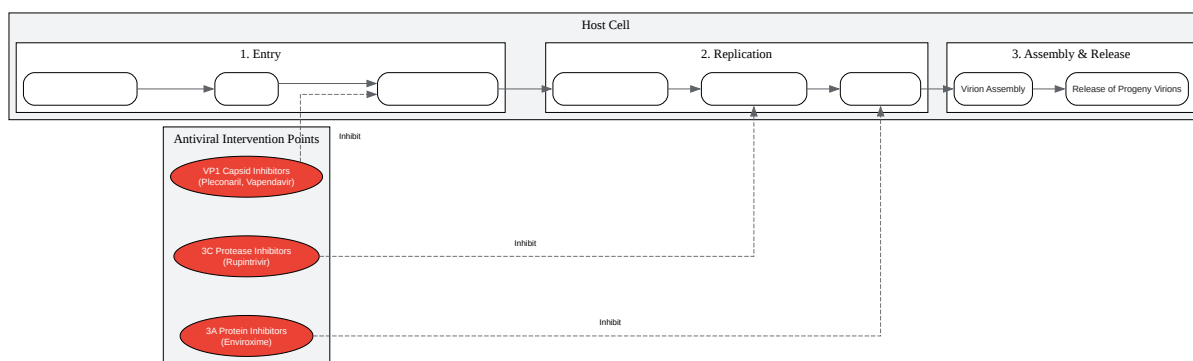

[Click to download full resolution via product page](#)

Caption: The Enterovirus A71 replication cycle and points of antiviral intervention.

Caption: A typical workflow for in vitro screening of anti-EV-A71 compounds.

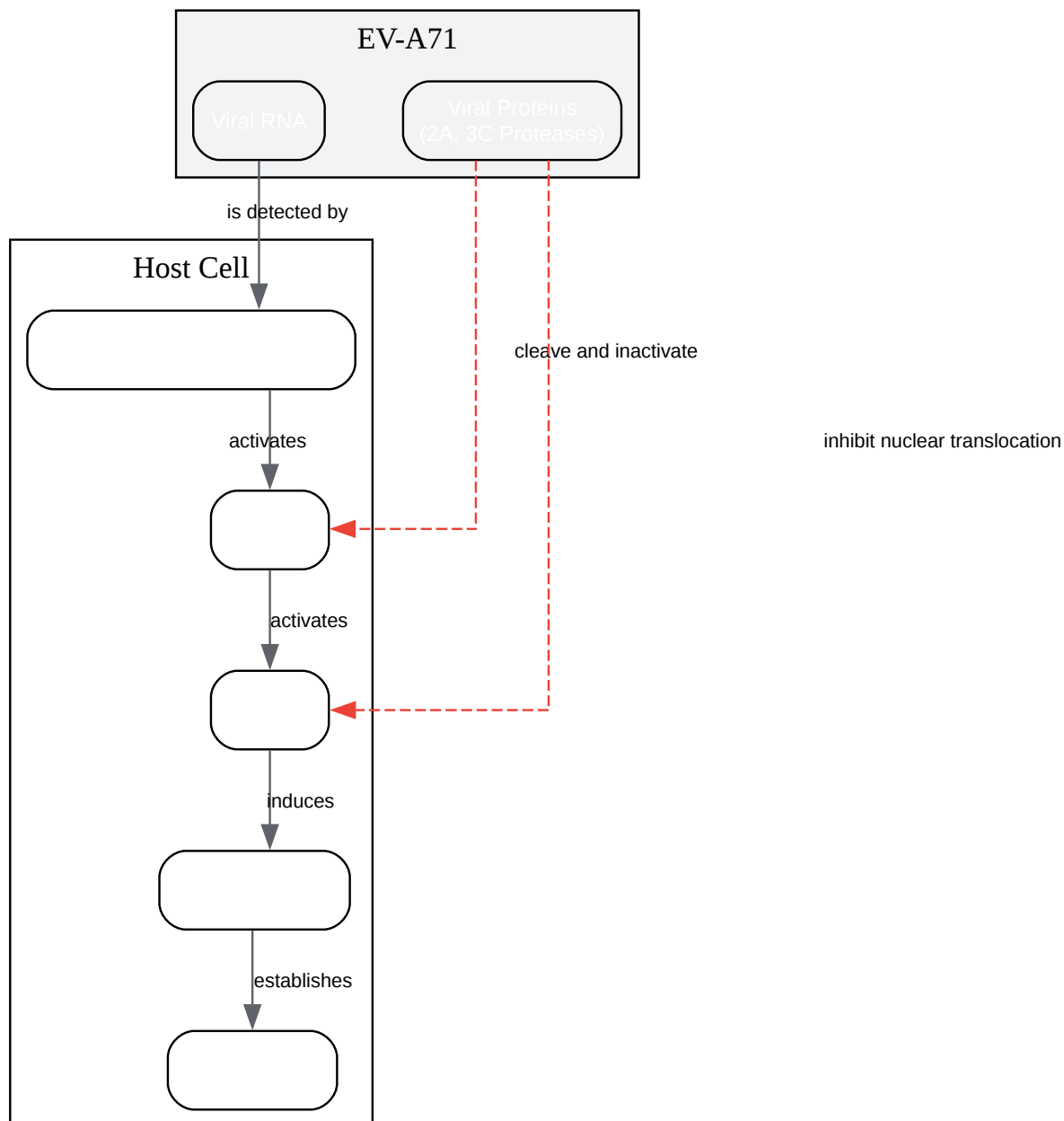

[Click to download full resolution via product page](#)

**Need Custom Synthesis?**

BenchChem offers custom synthesis for rare earth carbides and specific isotopic labeling.

Email: [info@benchchem.com](mailto:info@benchchem.com) or [Request Quote Online](#).

## References

- [1. file.medchemexpress.com](https://file.medchemexpress.com) [[file.medchemexpress.com](https://file.medchemexpress.com)]
- [2. Enterovirus A71 antivirals: Past, present, and future - PMC](https://pubmed.ncbi.nlm.nih.gov/) [[pmc.ncbi.nlm.nih.gov](https://pubmed.ncbi.nlm.nih.gov/)]
- [3. researchgate.net](https://researchgate.net) [[researchgate.net](https://researchgate.net)]
- [4. Crystal Structures of Enterovirus 71 3C Protease Complexed with Rupintrivir Reveal the Roles of Catalytically Important Residues - PMC](https://pubmed.ncbi.nlm.nih.gov/) [[pmc.ncbi.nlm.nih.gov](https://pubmed.ncbi.nlm.nih.gov/)]
- [5. researchgate.net](https://researchgate.net) [[researchgate.net](https://researchgate.net)]
- [6. medchemexpress.com](https://medchemexpress.com) [[medchemexpress.com](https://medchemexpress.com)]
- [7. merckmillipore.com](https://merckmillipore.com) [[merckmillipore.com](https://merckmillipore.com)]
- [8. Cytotoxicity MTT Assay Protocols and Methods | Springer Nature Experiments](https://experiments.springernature.com) [[experiments.springernature.com](https://experiments.springernature.com)]
- [9. broadpharm.com](https://broadpharm.com) [[broadpharm.com](https://broadpharm.com)]
- [10. CyQUANT MTT Cell Proliferation Assay Kit Protocol | Thermo Fisher Scientific - US](https://thermofisher.com) [[thermofisher.com](https://thermofisher.com)]
- [11. benchchem.com](https://benchchem.com) [[benchchem.com](https://benchchem.com)]
- [12. A simple and highly repeatable viral plaque assay for enterovirus 71 - PubMed](https://pubmed.ncbi.nlm.nih.gov/) [[pubmed.ncbi.nlm.nih.gov](https://pubmed.ncbi.nlm.nih.gov/)]
- [13. benchchem.com](https://benchchem.com) [[benchchem.com](https://benchchem.com)]
- [14. Methods in Screening Antiviral Drugs Against Enterovirus 71 - PubMed](https://pubmed.ncbi.nlm.nih.gov/) [[pubmed.ncbi.nlm.nih.gov](https://pubmed.ncbi.nlm.nih.gov/)]
- [15. researchgate.net](https://researchgate.net) [[researchgate.net](https://researchgate.net)]
- To cite this document: BenchChem. [Benchmarking EV-A71-IN-2: A Comparative Guide to Antiviral Performance]. BenchChem, [2026]. [Online PDF]. Available at: [<https://www.benchchem.com/product/b15564916/docs#benchmarking-ev-a71-in-2-a-comparative-guide-to-antiviral-performance>]

---

### Disclaimer & Data Validity:

The information provided in this document is for Research Use Only (RUO) and is strictly not intended for diagnostic or therapeutic procedures. While BenchChem strives to provide

accurate protocols, we make no warranties, express or implied, regarding the fitness of this product for every specific experimental setup.

**Technical Support:** The protocols provided are for reference purposes. Unsure if this reagent suits your experiment?

**Need Industrial/Bulk Grade?** [Request Custom Synthesis Quote](#)

## BenchChem

Our mission is to be the trusted global source of essential and advanced chemicals, empowering scientists and researchers to drive progress in science and industry.

### Contact

Address: 3281 E Guasti Rd

Ontario, CA 91761, United States

Phone: (601) 213-4426

Email: [info@benchchem.com](mailto:info@benchchem.com)

[Contact our Ph.D. Support Team for a compatibility check](#)