

Application Notes and Protocols for Norfloxacin Time-Kill Curve Analysis

Author: BenchChem Technical Support Team. **Date:** April 2026

Compound of Interest

Compound Name:	Norfloxacin
CAS No.:	68077-27-0; 70458-96-7
Cat. No.:	B15564001

[Get Quote](#)

For Researchers, Scientists, and Drug Development Professionals

These application notes provide a detailed methodology for conducting a **norfloxacin** time-kill curve analysis to determine its bactericidal or bacteriostatic activity against a specific bacterial strain.

Introduction

Norfloxacin is a broad-spectrum fluoroquinolone antibiotic that functions by inhibiting bacterial DNA gyrase (a type II topoisomerase) and topoisomerase IV.[1][2][3] These enzymes are essential for bacterial DNA replication, transcription, repair, and recombination.[2][4] By targeting these enzymes, **norfloxacin** disrupts critical cellular processes, ultimately leading to bacterial cell death.[2][5] The time-kill curve assay is a crucial in vitro pharmacodynamic method used to assess the rate and extent of bacterial killing by an antimicrobial agent over time.[6][7] This analysis helps to determine whether an agent is bactericidal (causes cell death) or bacteriostatic (inhibits growth) and provides insights into its concentration-dependent or time-dependent killing kinetics.[6][7] Bactericidal activity is typically defined as a ≥ 3 -log₁₀

(99.9%) reduction in the colony-forming units per milliliter (CFU/mL) compared to the initial inoculum.[6][8]

Key Experimental Protocols

A successful time-kill curve analysis requires careful preparation and execution. The following protocol outlines the necessary steps.

Materials and Reagents

- Bacterial Strain: A log-phase culture of the test organism.
- **Norfloxacin**: Stock solution of a known concentration.
- Growth Medium: Cation-adjusted Mueller-Hinton Broth (CAMHB) or another suitable broth.
- Plating Medium: Tryptic Soy Agar (TSA) or other appropriate solid agar.
- Sterile Saline: 0.9% NaCl solution for dilutions.
- Sterile test tubes or flasks.
- Sterile micropipette tips and micropipettes.
- Incubator (37°C).
- Spectrophotometer.
- Vortex mixer.
- Sterile petri dishes.
- Automated or manual colony counter.

Experimental Procedure

- Inoculum Preparation:

- From a fresh overnight culture plate, inoculate a single colony of the test organism into a tube of appropriate broth medium.[6]
- Incubate the culture at 37°C with shaking until it reaches the mid-logarithmic phase of growth. This is typically determined by measuring the optical density (OD) at 600 nm to a value corresponding to approximately $1-5 \times 10^8$ CFU/mL.[6]
- Dilute the bacterial suspension in fresh, pre-warmed broth to achieve a starting inoculum concentration of approximately 5×10^5 CFU/mL.[6]
- Verify the initial inoculum concentration by performing a viable count (plating serial dilutions) at time zero (T=0).[6]
- Time-Kill Assay Setup:
 - Prepare a series of tubes or flasks containing the appropriate growth medium with varying concentrations of **norfloxacin**. These concentrations are typically multiples of the Minimum Inhibitory Concentration (MIC) for the test organism (e.g., 0.25x, 0.5x, 1x, 2x, 4x, 8x MIC).
 - Include a growth control tube containing no antibiotic.
 - Inoculate each tube (including the growth control) with the prepared bacterial suspension to achieve the final target inoculum of approximately 5×10^5 CFU/mL.
- Incubation and Sampling:
 - Incubate all tubes at 37°C with shaking.
 - At predetermined time points (e.g., 0, 2, 4, 6, 8, 12, and 24 hours), collect an aliquot (e.g., 100 μ L) from each tube.[9][10]
- Quantification of Viable Bacteria:
 - Perform serial ten-fold dilutions of each collected sample in sterile saline.
 - Plate a specific volume (e.g., 100 μ L) of the appropriate dilutions onto agar plates.[6]

- Incubate the agar plates at 37°C for 18-24 hours, or until colonies are clearly visible.[6]
- Count the number of colonies on plates that contain between 30 and 300 colonies.[6]
- Data Analysis:
 - Calculate the CFU/mL for each time point and concentration using the formula: $\text{CFU/mL} = (\text{Number of colonies} \times \text{Dilution factor}) / \text{Volume plated (in mL)}$. [6]
 - Convert the CFU/mL values to log₁₀ CFU/mL. [6]
 - Plot the mean log₁₀ CFU/mL (Y-axis) against time (X-axis) for each **norfloxacin** concentration and the growth control to generate the time-kill curves.

Data Presentation

The results of the time-kill assay should be summarized in a clear and structured table for direct comparison of the different **norfloxacin** concentrations.

Norflo xacin Conce ntratio n ($\mu\text{g/mL}$)	Mean Log10 CFU/m L \pm SD (Time = 0 hr)	Mean Log10 CFU/m L \pm SD (Time = 2 hr)	Mean Log10 CFU/m L \pm SD (Time = 4 hr)	Mean Log10 CFU/m L \pm SD (Time = 6 hr)	Mean Log10 CFU/m L \pm SD (Time = 8 hr)	Mean Log10 CFU/m L \pm SD (Time = 12 hr)	Mean Log10 CFU/m L \pm SD (Time = 24 hr)	Log10 Reduct ion at 24 hr
Growth Control (0)	5.72 \pm 0.08	6.89 \pm 0.11	7.95 \pm 0.09	8.54 \pm 0.13	8.89 \pm 0.10	9.12 \pm 0.15	9.25 \pm 0.11	-3.53
0.5 x MIC	5.71 \pm 0.07	5.65 \pm 0.09	5.58 \pm 0.12	5.45 \pm 0.10	5.38 \pm 0.09	5.31 \pm 0.14	5.25 \pm 0.12	0.46
1 x MIC	5.73 \pm 0.09	4.88 \pm 0.10	4.12 \pm 0.11	3.56 \pm 0.08	3.11 \pm 0.13	2.89 \pm 0.11	2.75 \pm 0.10	2.98
2 x MIC	5.72 \pm 0.08	3.95 \pm 0.09	2.88 \pm 0.10	2.15 \pm 0.09	<2.00	<2.00	<2.00	>3.72
4 x MIC	5.71 \pm 0.07	2.98 \pm 0.08	<2.00	<2.00	<2.00	<2.00	<2.00	>3.71

Note: Data presented are hypothetical and for illustrative purposes only. The limit of detection is assumed to be 100 CFU/mL (2.00 log₁₀ CFU/mL).

Visualizations

Norfloxacin Mechanism of Action

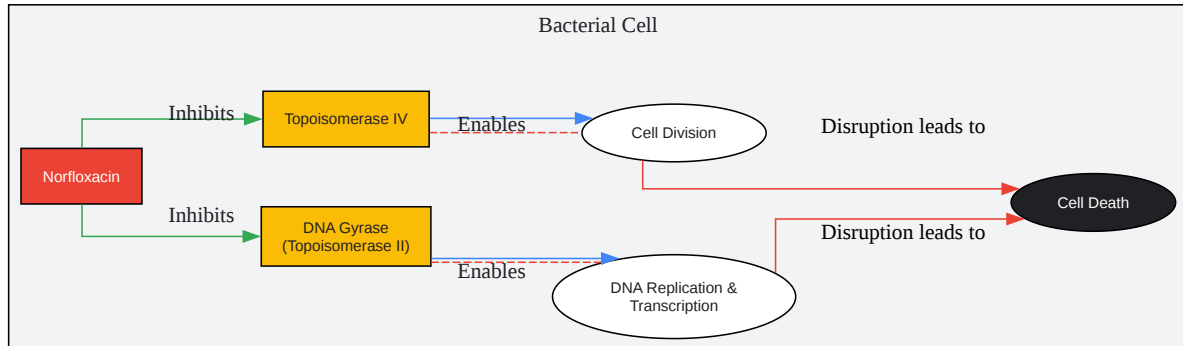



[Click to download full resolution via product page](#)

Need Custom Synthesis?

BenchChem offers custom synthesis for rare earth carbides and specific isotopic labeling.

Email: info@benchchem.com or [Request Quote Online](#).

References

- [1. Norfloxacin - Wikipedia \[en.wikipedia.org\]](#)
- [2. What is the mechanism of Norfloxacin? \[synapse.patsnap.com\]](#)
- [3. Norfloxacin, a fluoroquinolone antibacterial agent. Classification, mechanism of action, and in vitro activity - PubMed \[pubmed.ncbi.nlm.nih.gov\]](#)
- [4. discovery.researcher.life \[discovery.researcher.life\]](#)
- [5. go.drugbank.com \[go.drugbank.com\]](#)
- [6. benchchem.com \[benchchem.com\]](#)
- [7. DSpace \[helda.helsinki.fi\]](#)
- [8. actascientific.com \[actascientific.com\]](#)
- [9. A new time-kill method of assessing the relative efficacy of antimicrobial agents alone and in combination developed using a representative beta-lactam, aminoglycoside and fluoroquinolone - PubMed \[pubmed.ncbi.nlm.nih.gov\]](#)
- [10. Twenty-four-hour area under the concentration-time curve/MIC ratio as a generic predictor of fluoroquinolone antimicrobial effect by using three strains of Pseudomonas aeruginosa and an in vitro pharmacodynamic model - PubMed \[pubmed.ncbi.nlm.nih.gov\]](#)
- To cite this document: BenchChem. [Application Notes and Protocols for Norfloxacin Time-Kill Curve Analysis]. BenchChem, [2026]. [Online PDF]. Available at: [\[https://www.benchchem.com/product/b15564001/docs#application-notes-and-protocols-for-norfloxacin-time-kill-curve-analysis\]](https://www.benchchem.com/product/b15564001/docs#application-notes-and-protocols-for-norfloxacin-time-kill-curve-analysis)

Disclaimer & Data Validity:

The information provided in this document is for Research Use Only (RUO) and is strictly not intended for diagnostic or therapeutic procedures. While BenchChem strives to provide accurate protocols, we make no warranties, express or implied, regarding the fitness of this product for every specific experimental setup.

Technical Support: The protocols provided are for reference purposes. Unsure if this reagent suits your experiment?

Need Industrial/Bulk Grade? [Request Custom Synthesis Quote](#)

BenchChem

Our mission is to be the trusted global source of essential and advanced chemicals, empowering scientists and researchers to drive progress in science and industry.

Contact

Address: 3281 E Guasti Rd
Ontario, CA 91761, United States
Phone: (601) 213-4426
Email: info@benchchem.com

[Contact our Ph.D. Support Team for a compatibility check](#)