

# Technical Support Center: Sdh-IN-17 Application for Plant Pathogen Research

**Author:** BenchChem Technical Support Team. **Date:** April 2026

## Compound of Interest

Compound Name: *Sdh-IN-17*  
Cat. No.: *B15563294*

[Get Quote](#)

This technical support center provides researchers, scientists, and drug development professionals with essential information for the application of **Sdh-IN-17**, a potent succinate dehydrogenase (SDH) inhibitor, against specific plant pathogens.

## Frequently Asked Questions (FAQs)

Q1: What is the primary mode of action of **Sdh-IN-17**?

A1: **Sdh-IN-17** is a succinate dehydrogenase (SDH) inhibitor. It targets and binds to the SDH enzyme (also known as Complex II) in the mitochondrial respiratory chain of fungi. This binding action blocks the tricarboxylic acid (TCA) cycle at the point of succinate to fumarate oxidation, which inhibits cellular respiration and leads to a depletion of ATP, ultimately causing fungal cell death.[1][2][3] The mechanism of **Sdh-IN-17** also involves the disruption of the fungal cell membrane's structural integrity.[1]

Q2: Against which plant pathogens has **Sdh-IN-17** shown efficacy?

A2: **Sdh-IN-17** has demonstrated potent antifungal activity against the soil-borne plant pathogen *Rhizoctonia solani*. [1] *R. solani* is known to cause significant diseases in a wide variety of crops.

Q3: What are the known IC50 and EC50 values for **Sdh-IN-17**?

A3: The inhibitory concentrations for **Sdh-IN-17** are presented in the table below. The IC50 value represents the concentration required to inhibit the activity of the isolated SDH enzyme by 50%, while the EC50 value indicates the concentration needed to inhibit 50% of the fungal growth in vitro.

Q4: How can I prepare a stock solution of **Sdh-IN-17** for in vitro assays?

A4: To prepare a stock solution, dissolve **Sdh-IN-17** in a suitable solvent such as dimethyl sulfoxide (DMSO) or acetone. It is crucial to ensure the final solvent concentration in your experimental media is low (typically less than 1% v/v) and consistent across all treatments, including a solvent-only control, to avoid any inhibitory effects from the solvent itself.[4]

Q5: What is fungicide resistance and how can it affect my experiments with **Sdh-IN-17**?

A5: Fungicide resistance is the reduced sensitivity of a fungal population to a fungicide. For SDHI fungicides like **Sdh-IN-17**, resistance often arises from mutations in the genes encoding the subunits of the SDH enzyme (SdhB, SdhC, and SdhD).[3][5] These mutations can alter the binding site of the inhibitor, reducing its efficacy. If you observe that **Sdh-IN-17** is less effective than expected, it could be due to the use of a resistant strain of the pathogen.

## Quantitative Data Summary

The following table summarizes the known efficacy of **Sdh-IN-17**.

Compound	Target Organism/System	Parameter	Value
Sdh-IN-17	Succinate Dehydrogenase (SDH) Enzyme	IC50	8.42 $\mu$ M
Sdh-IN-17	Rhizoctonia solani	EC50	0.170 $\mu$ g/mL

## Experimental Protocols

## Protocol 1: Determination of EC50 of Sdh-IN-17 against Rhizoctonia solani using the Poisoned Food Technique

Objective: To determine the concentration of **Sdh-IN-17** that inhibits the mycelial growth of *Rhizoctonia solani* by 50%.

Materials:

- Pure culture of *Rhizoctonia solani*
- Potato Dextrose Agar (PDA) medium
- **Sdh-IN-17**
- Sterile distilled water
- Solvent (e.g., DMSO)
- Sterile Petri dishes (90 mm)
- Sterile cork borer (5 mm)
- Incubator

Procedure:

- Stock Solution Preparation: Prepare a stock solution of **Sdh-IN-17** in a suitable solvent (e.g., DMSO) at a high concentration (e.g., 10 mg/mL).
- Fungicide-Amended Media Preparation: a. Autoclave the PDA medium and allow it to cool to approximately 50-55°C in a water bath. b. Prepare serial dilutions of the **Sdh-IN-17** stock solution in sterile distilled water. c. Add the appropriate volume of each dilution to the molten PDA to achieve the desired final concentrations (e.g., 0, 0.01, 0.1, 1, 10, 100 µg/mL). d. Ensure the final solvent concentration is consistent across all plates, including the control (0 µg/mL **Sdh-IN-17**), and does not inhibit fungal growth (typically <1% v/v).[4] e. Mix thoroughly and pour approximately 20 mL of the amended agar into each sterile Petri dish. Allow the plates to solidify.[1]

- Inoculation: a. From the actively growing edge of a 3-5 day old culture of *R. solani*, use a sterile 5 mm cork borer to cut mycelial discs.[1] b. Place one mycelial disc, with the mycelium side facing down, in the center of each prepared Petri dish.[1]
- Incubation: a. Seal the Petri dishes with parafilm. b. Incubate the plates at  $25 \pm 2^\circ\text{C}$  in the dark.[1]
- Data Collection: a. Measure the radial growth (colony diameter) of the fungus in two perpendicular directions daily until the growth in the control plates reaches the edge of the dish.[1]
- Data Analysis: a. Calculate the percentage of mycelial growth inhibition for each concentration using the following formula:  $\% \text{ Inhibition} = [ (\text{Diameter of control} - \text{Diameter of treatment}) / \text{Diameter of control} ] \times 100$  b. Plot the percentage of inhibition against the logarithm of the **Sdh-IN-17** concentration. c. Use a suitable statistical software to perform a non-linear regression analysis (e.g., log-logistic dose-response) to determine the EC50 value.[4]

## Troubleshooting Guide

Issue	Possible Cause(s)	Recommended Solution(s)
High variability in EC50 values between replicates.	1. Inconsistent inoculum (age, size, or viability of mycelial plugs). 2. Uneven distribution of Sdh-IN-17 in the agar medium. 3. Fluctuation in incubation temperature or humidity.	1. Use mycelial plugs from the same actively growing culture plate and of a consistent size. 2. Ensure thorough mixing of the Sdh-IN-17 solution into the molten agar before pouring the plates. 3. Monitor and maintain stable incubation conditions.
No inhibition of fungal growth even at high concentrations of Sdh-IN-17.	1. The fungal strain may be resistant to SDHI fungicides. 2. Sdh-IN-17 may have degraded due to improper storage or handling. 3. The compound may have low solubility in the test medium.	1. Test the compound against a known sensitive (wild-type) strain of the pathogen. 2. Store Sdh-IN-17 according to the manufacturer's instructions, protected from light and moisture. Prepare fresh stock solutions for each experiment. 3. Check the solubility of Sdh-IN-17 in the chosen solvent and ensure it does not precipitate when added to the medium.
Inhibition of fungal growth in the solvent control plates.	The concentration of the solvent (e.g., DMSO) is too high and is toxic to the fungus.	Reduce the final concentration of the solvent in the agar medium to a non-inhibitory level (typically below 1% v/v). <a href="#">[4]</a>
Precipitation of Sdh-IN-17 in the stock solution or media.	Sdh-IN-17 has exceeded its solubility limit in the chosen solvent or medium.	1. Gently warm the stock solution to aid dissolution. 2. Prepare a more dilute stock solution. 3. Consider using a different co-solvent system if compatible with the experimental setup.

## Visualizations

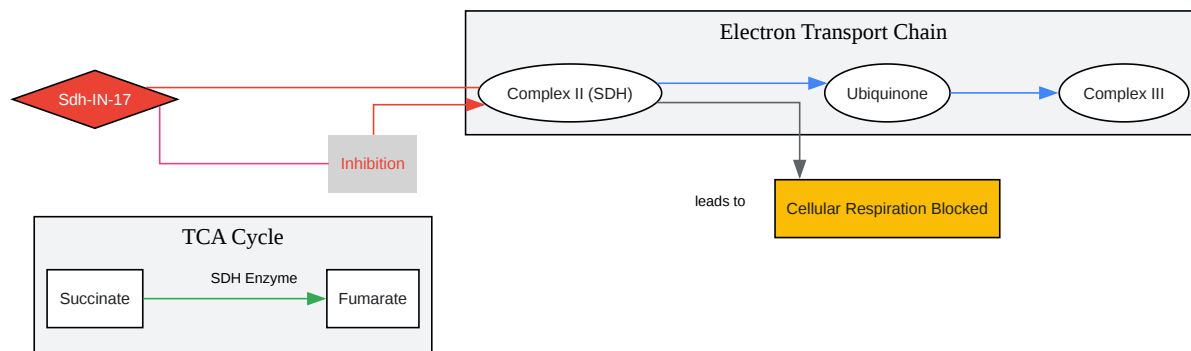

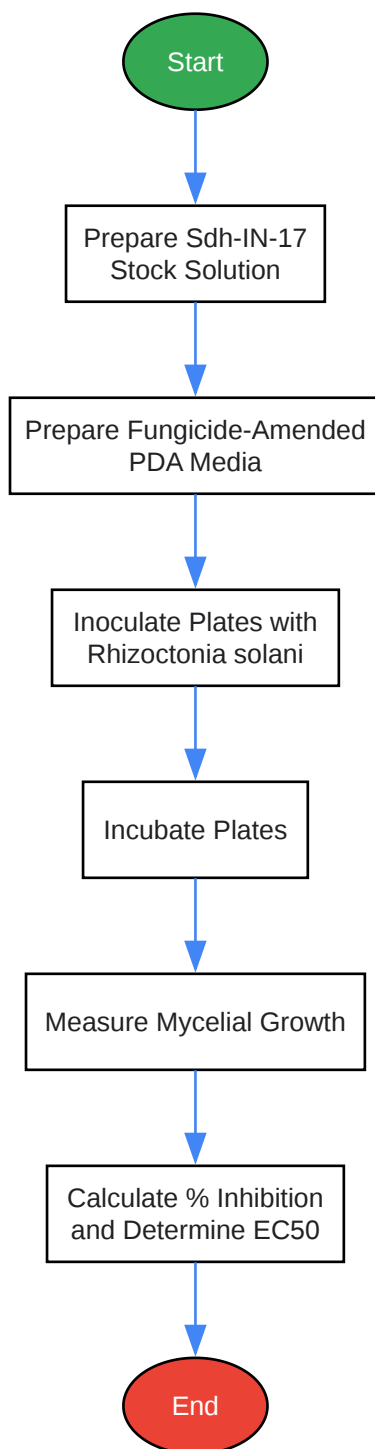

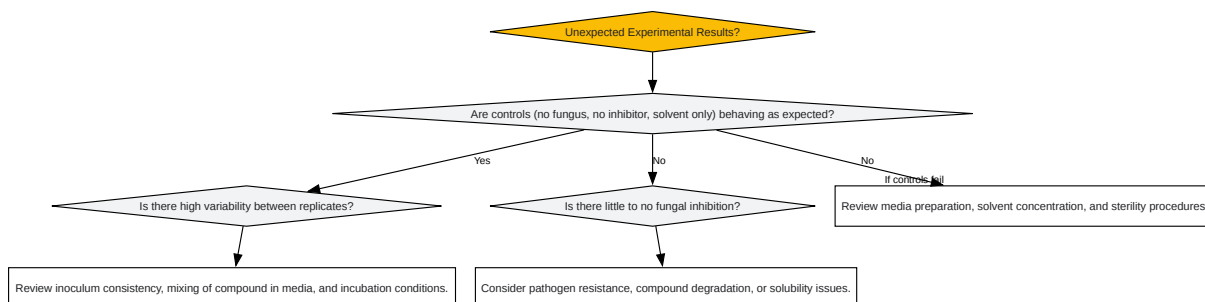

[Click to download full resolution via product page](#)

### Need Custom Synthesis?

BenchChem offers custom synthesis for rare earth carbides and specific isotopic labeling.

Email: [info@benchchem.com](mailto:info@benchchem.com) or [Request Quote Online](#).

## References

- [1. benchchem.com \[benchchem.com\]](https://www.benchchem.com)
- [2. Inhibition of Succinate Dehydrogenase by Pesticides \(SDHIs\) and Energy Metabolism - PMC \[pmc.ncbi.nlm.nih.gov\]](https://pubmed.ncbi.nlm.nih.gov/123456789/)
- [3. researchgate.net \[researchgate.net\]](https://www.researchgate.net/)
- [4. benchchem.com \[benchchem.com\]](https://www.benchchem.com)
- [5. benchchem.com \[benchchem.com\]](https://www.benchchem.com)
- To cite this document: BenchChem. [Technical Support Center: Sdh-IN-17 Application for Plant Pathogen Research]. BenchChem, [2026]. [Online PDF]. Available at: [\[https://www.benchchem.com/product/b15563294/docs#technical-support-center-sdh-in-17-application-for-plant-pathogen-research\]](https://www.benchchem.com/product/b15563294/docs#technical-support-center-sdh-in-17-application-for-plant-pathogen-research)

**Disclaimer & Data Validity:**

The information provided in this document is for Research Use Only (RUO) and is strictly not intended for diagnostic or therapeutic procedures. While BenchChem strives to provide accurate protocols, we make no warranties, express or implied, regarding the fitness of this product for every specific experimental setup.

**Technical Support:** The protocols provided are for reference purposes. Unsure if this reagent suits your experiment?

**Need Industrial/Bulk Grade?** [Request Custom Synthesis Quote](#)

## BenchChem

Our mission is to be the trusted global source of essential and advanced chemicals, empowering scientists and researchers to drive progress in science and industry.

### Contact

Address: 3281 E Guasti Rd  
Ontario, CA 91761, United States  
Phone: (601) 213-4426  
Email: [info@benchchem.com](mailto:info@benchchem.com)

[Contact our Ph.D. Support Team for a compatibility check](#)