

Technical Support Center: Pradimicin L

Spectrophotometric Analysis

Author: BenchChem Technical Support Team. **Date:** April 2026

Compound of Interest

Compound Name: Pradimicin L

Cat. No.: B15563504

[Get Quote](#)

This technical support center provides troubleshooting guidance and frequently asked questions (FAQs) for the spectrophotometric analysis of **Pradimicin L**. The information is tailored for researchers, scientists, and drug development professionals.

Frequently Asked Questions (FAQs)

Q1: What is the principle behind the spectrophotometric analysis of **Pradimicin L**?

The spectrophotometric analysis of **Pradimicin L** is based on its intrinsic chromophore, a dihydrobenzo[a]naphthacenequinone structure, which absorbs light in the UV-visible region.^[1] The analysis can be a direct measurement of its absorbance or can be based on the change in its absorption spectrum upon interaction with other molecules. Pradimicins are known to form a ternary complex with D-mannosides and calcium ions, leading to a shift in the maximum absorption wavelength, which can be utilized for quantification.^[1]

Q2: What is the expected wavelength of maximum absorbance (λ_{max}) for **Pradimicin L**?

While specific data for **Pradimicin L** is not readily available in public literature, its structural analogs and the general class of pradimicins suggest absorbance in the visible range. For instance, a pradimicin derivative, BMS-181184, is detected by UV absorbance at 510 nm. It is

recommended to perform a wavelength scan (e.g., from 200 to 800 nm) on a purified **Pradimicin L** standard to determine its specific λ_{max} in the chosen solvent.

Q3: What solvents are suitable for the spectrophotometric analysis of **Pradimicin L**?

The choice of solvent is critical and can influence the absorption spectrum. **Pradimicin L**'s solubility should be determined in various common solvents such as water, methanol, ethanol, and dimethyl sulfoxide (DMSO). The ideal solvent should dissolve **Pradimicin L** completely, be transparent in the wavelength range of interest, and not react with the analyte. For analyses involving the formation of a ternary complex, an aqueous buffer system is likely required.

Q4: How can I validate my spectrophotometric method for **Pradimicin L**?

Method validation should be performed according to ICH guidelines and should include the following parameters:

- **Specificity:** The ability to assess the analyte unequivocally in the presence of components that may be expected to be present, such as impurities, degradation products, or matrix components.
- **Linearity:** The ability to elicit test results that are directly proportional to the concentration of the analyte.
- **Range:** The interval between the upper and lower concentrations of the analyte that have been demonstrated to be determined with suitable precision, accuracy, and linearity.
- **Accuracy:** The closeness of the test results obtained by the method to the true value.
- **Precision:** The degree of agreement among individual test results when the method is applied repeatedly to multiple samplings of a homogeneous sample. This includes repeatability (intra-day precision) and intermediate precision (inter-day precision).
- **Limit of Detection (LOD):** The lowest amount of analyte in a sample that can be detected but not necessarily quantitated as an exact value.
- **Limit of Quantitation (LOQ):** The lowest amount of analyte in a sample that can be quantitatively determined with suitable precision and accuracy.

- **Robustness:** A measure of its capacity to remain unaffected by small, but deliberate variations in method parameters.

Experimental Protocols

Protocol 1: Determination of λ_{\max} of Pradimicin L

Objective: To determine the wavelength of maximum absorbance (λ_{\max}) of **Pradimicin L**.

Materials:

- **Pradimicin L** reference standard
- Spectrophotometer-grade solvent (e.g., Methanol, DMSO, or a suitable buffer)
- UV-Vis Spectrophotometer
- Quartz cuvettes (1 cm path length)

Methodology:

- Prepare a stock solution of **Pradimicin L** of known concentration (e.g., 100 $\mu\text{g}/\text{mL}$) in the chosen solvent.
- Dilute the stock solution to an appropriate concentration (e.g., 10 $\mu\text{g}/\text{mL}$) that gives an absorbance reading between 0.5 and 1.5 AU.
- Use the same solvent as a blank to zero the spectrophotometer.
- Scan the absorbance of the **Pradimicin L** solution over a wavelength range of 200-800 nm.
- The wavelength at which the highest absorbance is recorded is the λ_{\max} .

Protocol 2: Quantitative Analysis of Pradimicin L

Objective: To quantify the concentration of **Pradimicin L** in a sample using a calibration curve.

Materials:

- **Pradimicin L** reference standard
- Chosen solvent/buffer
- Volumetric flasks and pipettes
- UV-Vis Spectrophotometer

Methodology:

- Preparation of Standard Solutions:
 - Prepare a stock solution of **Pradimicin L** (e.g., 100 µg/mL).
 - From the stock solution, prepare a series of standard solutions with concentrations ranging from, for example, 2 to 20 µg/mL.
- Calibration Curve:
 - Set the spectrophotometer to the predetermined λ_{max} of **Pradimicin L**.
 - Use the solvent/buffer as a blank.
 - Measure the absorbance of each standard solution.
 - Plot a graph of absorbance versus concentration. .
- Sample Analysis:
 - Prepare the sample solution, ensuring the expected concentration falls within the range of the calibration curve. Dilute if necessary.
 - Measure the absorbance of the sample solution at the λ_{max} .
 - Determine the concentration of **Pradimicin L** in the sample by interpolating the absorbance value on the calibration curve or using the regression equation.

Troubleshooting Guides

Problem	Possible Causes	Solutions
No or Low Absorbance	<ol style="list-style-type: none"> 1. Incorrect wavelength setting. 2. Pradimicin L concentration is too low. 3. Instrument malfunction (e.g., lamp not on). 4. Pradimicin L degradation. 	<ol style="list-style-type: none"> 1. Verify the λ_{max} by performing a new wavelength scan. 2. Prepare a more concentrated sample. 3. Check the instrument's status and perform a system check. 4. Prepare fresh solutions and protect from light and extreme temperatures.
High Absorbance (>2.0 AU)	<ol style="list-style-type: none"> 1. Pradimicin L concentration is too high. 2. Presence of interfering substances. 3. Incorrect blank solution used. 	<ol style="list-style-type: none"> 1. Dilute the sample to bring the absorbance within the linear range (typically 0.1-1.5 AU). 2. Analyze a placebo/matrix blank to check for interference. If interference is present, sample cleanup may be necessary. 3. Ensure the blank contains all components of the sample solvent/matrix except for Pradimicin L.
Non-linear Calibration Curve	<ol style="list-style-type: none"> 1. Concentrations are outside the linear range of the assay. 2. Aggregation of Pradimicin L at higher concentrations. 3. Instrumental limitations at high absorbances. 	<ol style="list-style-type: none"> 1. Narrow the concentration range of the standards. 2. Investigate the solubility and aggregation behavior of Pradimicin L in the chosen solvent. Consider using a different solvent or adding agents to prevent aggregation. 3. Ensure absorbance readings are within the optimal range of the instrument.

Poor Reproducibility (High %RSD)	1. Inaccurate pipetting or dilutions.2. Cuvette is not clean or is scratched.3. Fluctuation in instrument performance.4. Sample instability.	1. Use calibrated pipettes and follow proper dilution techniques.2. Clean cuvettes thoroughly between measurements and handle with care. Use a matched pair of cuvettes.3. Allow the instrument to warm up properly. Perform regular performance checks.4. Analyze samples promptly after preparation. Investigate the stability of Pradimicin L in the chosen solvent over time.
Shifting λ_{\max}	1. Change in solvent polarity or pH.2. Interaction of Pradimicin L with other molecules (e.g., cations, sugars).3. Degradation of Pradimicin L.	1. Ensure consistent solvent composition and pH for all standards and samples.2. If the assay is based on complex formation, ensure consistent concentrations of all interacting components.3. Perform forced degradation studies to understand the degradation profile and its effect on the UV-Vis spectrum.

Data Presentation

Table 1: Validation Parameters for a Hypothetical **Pradimicin L** Spectrophotometric Assay

Parameter	Result
λ_{\max}	510 nm
Linearity Range	0.2 - 20.0 $\mu\text{g/mL}$
Correlation Coefficient (r^2)	0.9995
Molar Absorptivity (ϵ)	To be determined
Limit of Detection (LOD)	0.05 $\mu\text{g/mL}$
Limit of Quantitation (LOQ)	0.15 $\mu\text{g/mL}$
Accuracy (% Recovery)	98.5% - 101.2%
Precision (%RSD)	
- Repeatability (Intra-day)	< 1.5%
- Intermediate Precision (Inter-day)	< 2.0%

Visualizations

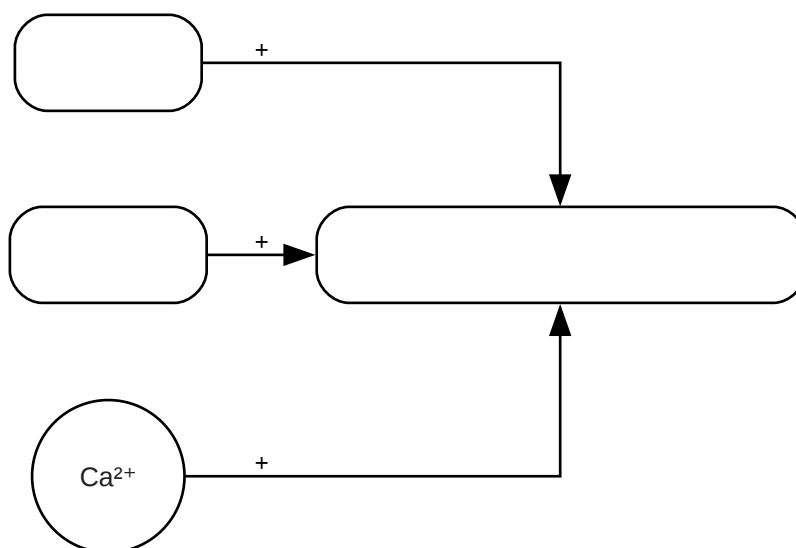

[Click to download full resolution via product page](#)

Caption: Ternary complex formation of **Pradimicin L**.

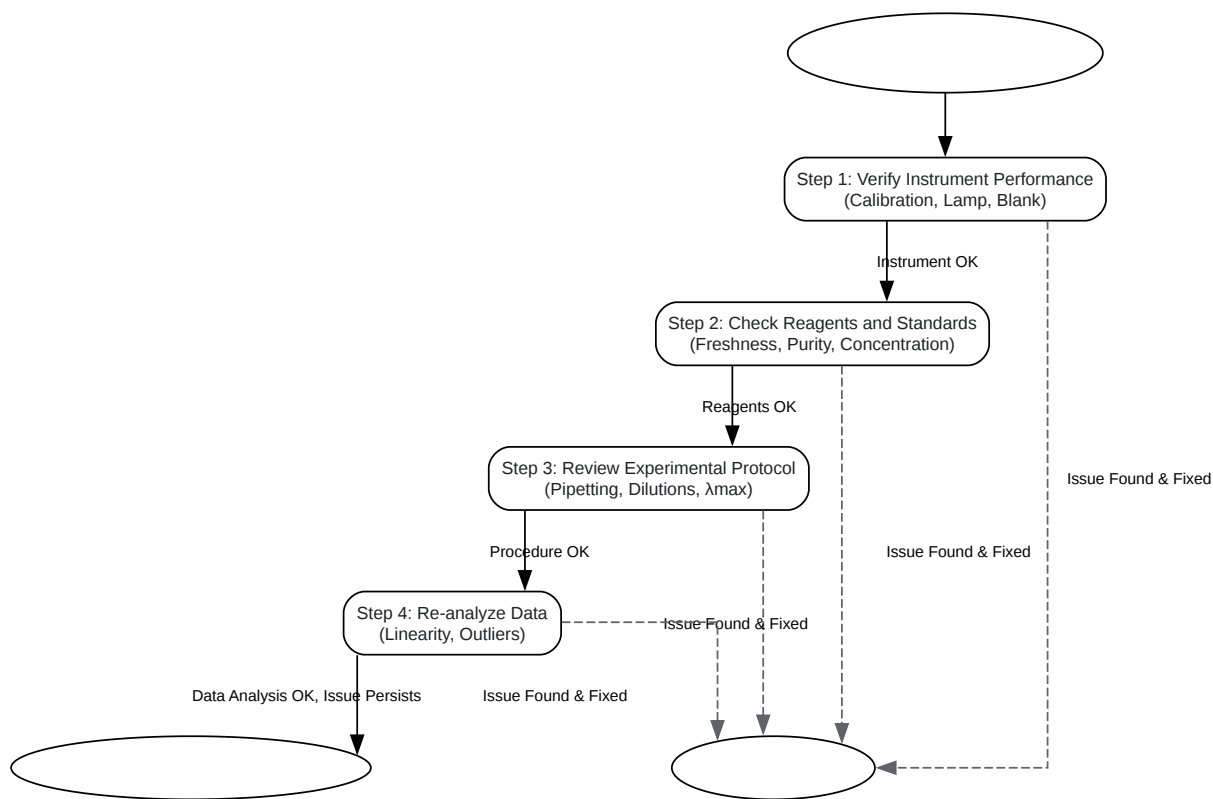

[Click to download full resolution via product page](#)

Caption: General troubleshooting workflow for spectrophotometric analysis.

Need Custom Synthesis?

BenchChem offers custom synthesis for rare earth carbides and specific isotopic labeling.

Email: info@benchchem.com or [Request Quote Online](#).

References

- [1. Pradimicins: a novel class of broad-spectrum antifungal compounds - PubMed](#) [pubmed.ncbi.nlm.nih.gov]
- To cite this document: BenchChem. [Technical Support Center: Pradimicin L Spectrophotometric Analysis]. BenchChem, [2026]. [Online PDF]. Available at: [https://www.benchchem.com/product/b15563504/docs#technical-support-center-pradimicin-l-spectrophotometric-analysis]

Disclaimer & Data Validity:

The information provided in this document is for Research Use Only (RUO) and is strictly not intended for diagnostic or therapeutic procedures. While BenchChem strives to provide accurate protocols, we make no warranties, express or implied, regarding the fitness of this product for every specific experimental setup.

Technical Support: The protocols provided are for reference purposes. Unsure if this reagent suits your experiment?

Need Industrial/Bulk Grade? [Request Custom Synthesis Quote](#)

BenchChem

Our mission is to be the trusted global source of essential and advanced chemicals, empowering scientists and researchers to drive progress in science and industry.

Contact

Address: 3281 E Guasti Rd
Ontario, CA 91761, United States
Phone: (601) 213-4426
Email: info@benchchem.com

[Contact our Ph.D. Support Team for a compatibility check](#)