

Technical Support Center: Minimizing Interferon Response to AMPD2 siRNA

Author: BenchChem Technical Support Team. **Date:** April 2026

Compound of Interest

Compound Name: *AMPD2 Human Pre-designed
siRNA Set A*

Cat. No.: *B15563721*

[Get Quote](#)

This technical support center provides researchers, scientists, and drug development professionals with comprehensive guidance on minimizing the innate immune response often associated with small interfering RNA (siRNA) delivery, with a focus on targeting Adenosine Monophosphate Deaminase 2 (AMPD2).

Frequently Asked Questions (FAQs)

Q1: What is the interferon response in the context of siRNA experiments?

A1: The interferon response is a part of the body's innate immune system, which is the first line of defense against pathogens like viruses. In the context of siRNA experiments, synthetic siRNA molecules can sometimes be recognized by the cell as foreign or virus-derived, leading to the activation of signaling pathways that result in the production of type I interferons (e.g., IFN- α , IFN- β) and other inflammatory cytokines.[1][2] This can lead to off-target effects and misinterpretation of experimental results.[3][4]

Q2: Why is it important to minimize the interferon response when using AMPD2 siRNA?

A2: Minimizing the interferon response is crucial for several reasons. Firstly, the activation of interferon-stimulated genes (ISGs) can have broad, pleiotropic effects on cell physiology, including cell growth, apoptosis, and gene expression, which can confound the specific effects of AMPD2 knockdown. Secondly, a strong immune response can lead to cellular toxicity.[5] Finally, for therapeutic applications, inducing an immune response can lead to adverse side effects.[6]

Q3: Are siRNAs targeting AMPD2 more likely to cause an interferon response?

A3: There is currently no evidence to suggest that siRNAs targeting AMPD2 are inherently more immunostimulatory than siRNAs targeting other genes. The general principles and strategies for minimizing the interferon response apply to AMPD2 siRNA experiments.

Q4: What are the primary cellular sensors that detect siRNA and trigger this response?

A4: The primary cellular sensors, also known as Pattern Recognition Receptors (PRRs), that can detect siRNA include:

- Toll-like receptors (TLRs): TLR3, TLR7, and TLR8 are located in endosomes and can recognize double-stranded and single-stranded RNA.[3][7]
- RIG-I-like receptors (RLRs): RIG-I and MDA5 are located in the cytoplasm and can detect features of viral RNA, such as double-strandedness and 5'-triphosphate groups.[2][3]

Q5: What are the key characteristics of an siRNA that can trigger an interferon response?

A5: Several siRNA characteristics can contribute to immune activation:

- Length: Duplexes longer than 30 base pairs are potent activators, though even shorter siRNAs can trigger a response in some cell types.[5][8]
- Sequence motifs: Certain sequences, such as GU-rich regions, are known to be immunostimulatory.[2]
- Blunt ends: siRNA duplexes with blunt ends can be recognized by RIG-I.[2]

- 5' triphosphate: The presence of a 5' triphosphate group is a strong signal for RIG-I activation.[\[7\]](#)
- Impurities: Contaminants from siRNA synthesis, such as long dsRNA, can be highly immunostimulatory.[\[9\]](#)[\[10\]](#)

Troubleshooting Guides

Problem 1: High expression of interferon-stimulated genes (ISGs) post-transfection with AMPD2 siRNA.

Possible Causes and Solutions:

Possible Cause	Solution
siRNA concentration is too high.	Titrate the AMPD2 siRNA concentration to the lowest effective dose that achieves the desired knockdown. A typical starting range is 1-30 nM. [8]
Immunostimulatory siRNA sequence.	Redesign the AMPD2 siRNA to avoid known immunostimulatory motifs. Use siRNA design tools that account for potential off-target effects. [11] Consider using a pool of multiple siRNAs targeting AMPD2 to reduce the concentration of any single potentially immunostimulatory siRNA. [12] [13]
Contaminants in the siRNA preparation.	Use highly purified siRNA. HPLC or PAGE purification is recommended to remove synthesis byproducts. [10] [14]
Transfection reagent-induced toxicity/immunostimulation.	Optimize the transfection protocol by titrating the reagent-to-siRNA ratio. [15] Test different transfection reagents, as some are specifically formulated for low immunogenicity.
Cell type is particularly sensitive.	Some cell lines are more prone to mounting an interferon response. [16] If possible, test your AMPD2 siRNA in a less sensitive cell line first.

Problem 2: Poor AMPD2 knockdown efficiency accompanied by cellular toxicity.

Possible Causes and Solutions:

Possible Cause	Solution
Combined effect of off-target silencing and interferon response.	This is a common issue where the observed phenotype is not solely due to the knockdown of the target gene.
1. Use chemically modified siRNA: Incorporate 2'-O-methyl (2'-OMe) or 2'-fluoro (2'-F) modifications into the siRNA backbone. These modifications can significantly reduce the interferon response without affecting silencing efficiency. [17] [18] [19] [20]	
2. Confirm knockdown with multiple siRNAs: Use at least two different siRNAs targeting different regions of the AMPD2 mRNA to ensure the observed phenotype is consistent.	
3. Include proper controls: Always include a non-targeting (scrambled) siRNA control and a positive control siRNA targeting a housekeeping gene. [8]	
4. Rescue experiment: If possible, perform a rescue experiment by re-introducing an siRNA-resistant form of AMPD2 to see if it reverses the observed phenotype.	
Suboptimal transfection conditions.	Optimize cell confluency (typically 60-80%) and minimize the duration of cell exposure to the transfection complex. [9] [15]

Quantitative Data Summary

The following table summarizes hypothetical quantitative data from an experiment designed to optimize AMPD2 siRNA transfection and minimize the interferon response, as measured by the expression of the interferon-stimulated gene, OAS1.

Condition	AMPD2 mRNA Level (relative to control)	OAS1 mRNA Level (relative to control)	Cell Viability (%)
Untransfected Control	1.00	1.00	100
Scrambled siRNA (10 nM)	0.98	1.10	98
AMPD2 siRNA (unmodified, 30 nM)	0.25	15.2	75
AMPD2 siRNA (unmodified, 10 nM)	0.45	5.8	90
AMPD2 siRNA (2'- OMe modified, 10 nM)	0.42	1.5	95
AMPD2 siRNA Pool (unmodified, 10 nM total)	0.40	3.2	92

This data illustrates that using a lower concentration of siRNA, and particularly a chemically modified siRNA, can effectively reduce the off-target interferon response (lower OAS1 levels) while maintaining significant knockdown of the target gene (AMPD2) and improving cell viability.

Experimental Protocols

Protocol 1: Quantification of Interferon Response using qRT-PCR

This protocol describes how to measure the induction of interferon-stimulated genes (ISGs) following siRNA transfection.

- Cell Seeding and Transfection:

- Seed cells in a 24-well plate at a density that will result in 60-80% confluency at the time of transfection.
- Transfect cells with your AMPD2 siRNA, a non-targeting control siRNA, and a positive control (e.g., poly(I:C), a known interferon inducer) using an optimized transfection protocol.[21] Include an untransfected control.
- RNA Extraction:
 - At 24-48 hours post-transfection, lyse the cells and extract total RNA using a commercially available kit according to the manufacturer's instructions.
 - Assess RNA quality and quantity using a spectrophotometer or a bioanalyzer.
- cDNA Synthesis:
 - Synthesize cDNA from 1 µg of total RNA using a reverse transcription kit with random primers or oligo(dT) primers.
- Quantitative Real-Time PCR (qRT-PCR):
 - Perform qRT-PCR using a SYBR Green or probe-based assay with primers specific for your ISGs of interest (e.g., OAS1, IFIT1, STAT1) and a housekeeping gene for normalization (e.g., GAPDH, ACTB).[21]
 - Set up the following reactions in triplicate:
 - Your cDNA samples
 - No-template control (NTC)
 - No-reverse-transcriptase control (-RT)
 - Run the PCR on a real-time PCR instrument.
- Data Analysis:

- Calculate the relative expression of the ISGs using the $\Delta\Delta C_t$ method, normalizing to the housekeeping gene and comparing to the untransfected or scrambled siRNA control.

Visualizations

Signaling Pathway of siRNA-Induced Interferon Response

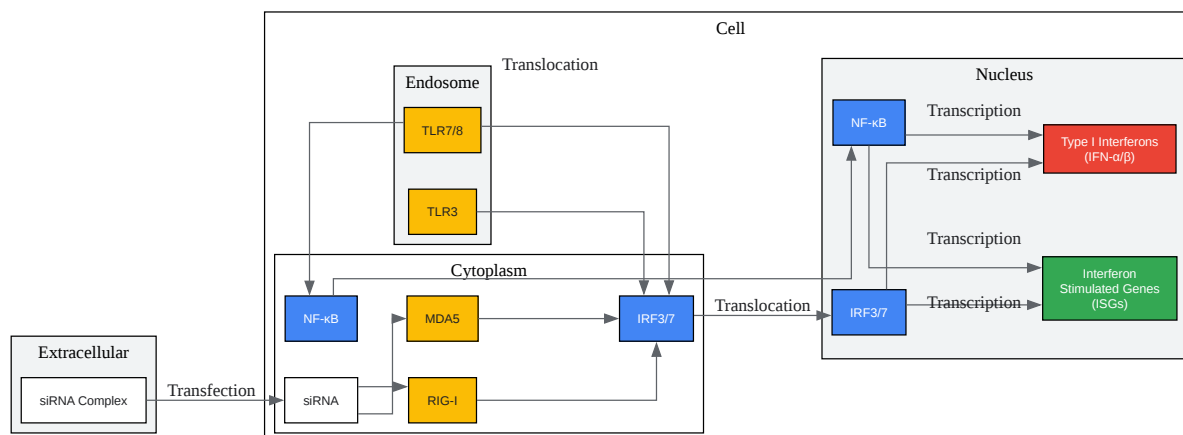

[Click to download full resolution via product page](#)

Caption: Signaling pathways for siRNA-induced interferon response.

Experimental Workflow for Minimizing Interferon Response

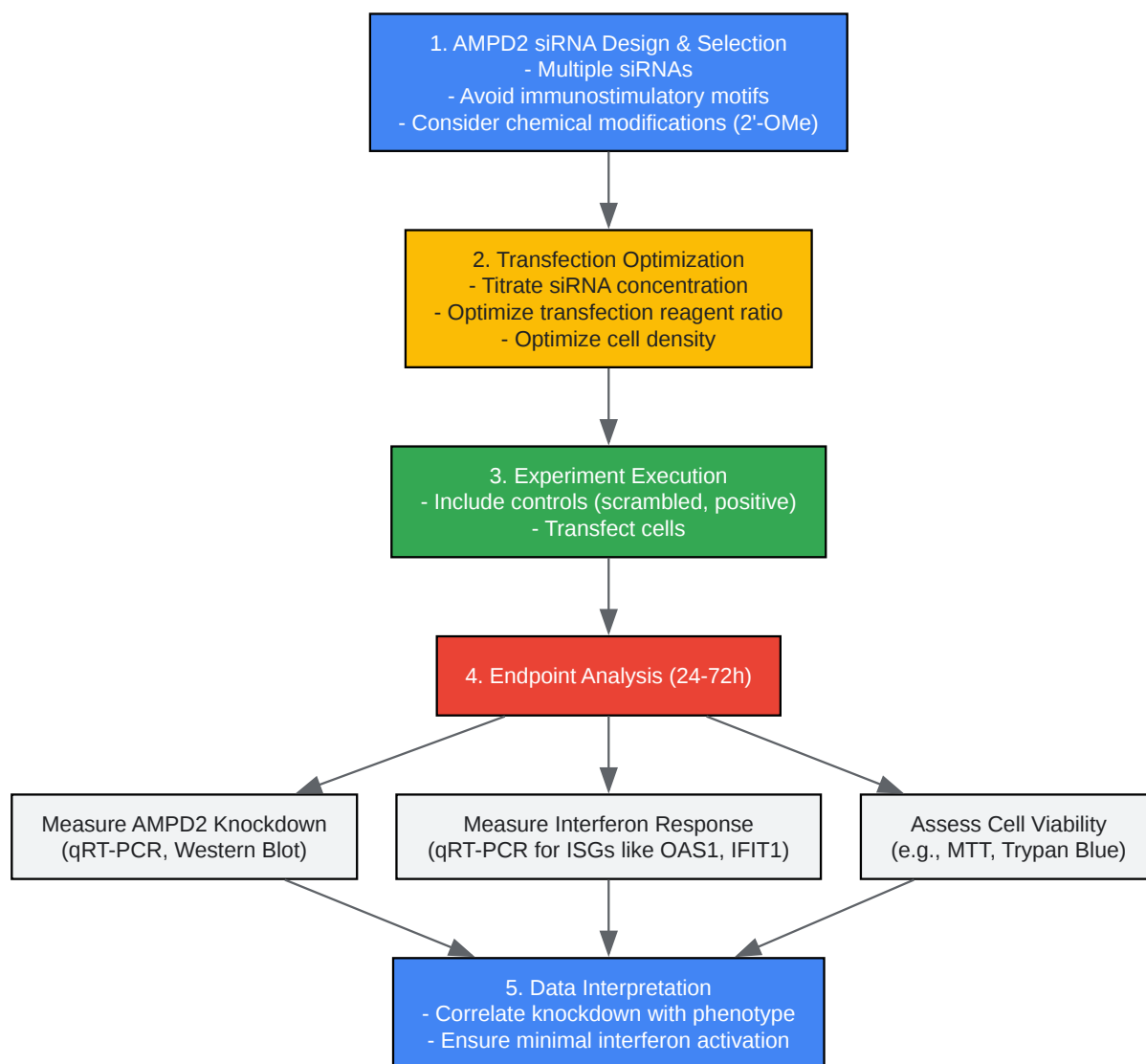

[Click to download full resolution via product page](#)

Caption: Workflow for optimizing AMPD2 siRNA experiments.

Logical Flow for Troubleshooting High Interferon Response

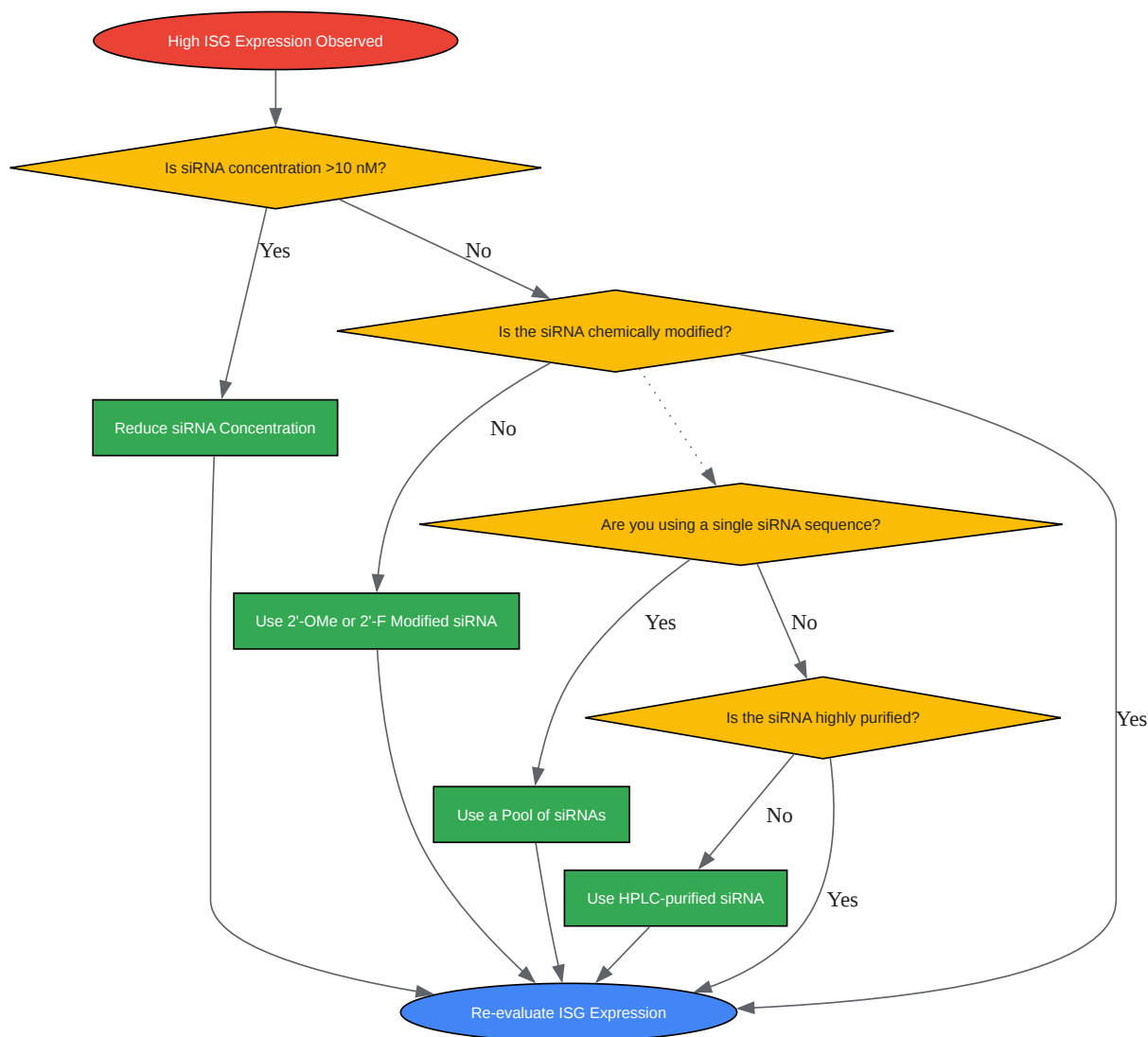

[Click to download full resolution via product page](#)

Caption: Troubleshooting guide for high interferon response.

Need Custom Synthesis?

BenchChem offers custom synthesis for rare earth carbides and specific isotopic labeling.

Email: info@benchchem.com or [Request Quote Online](#).

References

- [1. academic.oup.com \[academic.oup.com\]](https://academic.oup.com)
- [2. RNA Interference-Induced Innate Immunity, Off-Target Effect, or Immune Adjuvant? - PMC \[pmc.ncbi.nlm.nih.gov\]](#)
- [3. pblassaysci.com \[pblassaysci.com\]](https://pblassaysci.com)
- [4. siRNA-mediated off-target gene silencing triggered by a 7 nt complementation - PMC \[pmc.ncbi.nlm.nih.gov\]](#)
- [5. Editorial focus: understanding off-target effects as the key to successful RNAi therapy - PMC \[pmc.ncbi.nlm.nih.gov\]](#)
- [6. Silencing or stimulation? siRNA delivery and the immune system - PubMed \[pubmed.ncbi.nlm.nih.gov\]](#)
- [7. siRNA and the immune system \[biosyn.com\]](https://biosyn.com)
- [8. Optimizing siRNA Transfection for RNAi | Thermo Fisher Scientific - SG \[thermofisher.com\]](#)
- [9. Top Ten Ways to Optimize siRNA Delivery in Cultured Cells | Thermo Fisher Scientific - HK \[thermofisher.com\]](#)
- [10. ads-tec.co.jp \[ads-tec.co.jp\]](https://ads-tec.co.jp)
- [11. Designing functional siRNA with reduced off-target effects - PubMed \[pubmed.ncbi.nlm.nih.gov\]](#)
- [12. Methods for reducing siRNA off-target binding | Eclipsebio \[eclipsebio.com\]](#)
- [13. sitoolsbiotech.com \[sitoolsbiotech.com\]](https://sitoolsbiotech.com)
- [14. What are the purification options for your custom oligo or siRNA synthesis? \[horizondiscovery.com\]](#)
- [15. yeasenbio.com \[yeasenbio.com\]](https://yeasenbio.com)
- [16. Induction of the interferon response by siRNA is cell type– and duplex length–dependent - PMC \[pmc.ncbi.nlm.nih.gov\]](#)

- [17. Therapeutic potential of chemically modified siRNA: Recent trends - PMC \[pmc.ncbi.nlm.nih.gov\]](#)
- [18. researchgate.net \[researchgate.net\]](#)
- [19. Structural Modifications of siRNA Improve Its Performance In Vivo \[mdpi.com\]](#)
- [20. Analysis and Application of Chemical Modification Strategies for Small Nucleic Acid Drugs \[synapse.patsnap.com\]](#)
- [21. cdn.technologynetworks.com \[cdn.technologynetworks.com\]](#)
- To cite this document: BenchChem. [Technical Support Center: Minimizing Interferon Response to AMPD2 siRNA]. BenchChem, [2026]. [Online PDF]. Available at: [\[https://www.benchchem.com/product/b15563721/docs#technical-support-center-minimizing-interferon-response-to-ampd2-sirna\]](https://www.benchchem.com/product/b15563721/docs#technical-support-center-minimizing-interferon-response-to-ampd2-sirna)

Disclaimer & Data Validity:

The information provided in this document is for Research Use Only (RUO) and is strictly not intended for diagnostic or therapeutic procedures. While BenchChem strives to provide accurate protocols, we make no warranties, express or implied, regarding the fitness of this product for every specific experimental setup.

Technical Support: The protocols provided are for reference purposes. Unsure if this reagent suits your experiment?

Need Industrial/Bulk Grade? [Request Custom Synthesis Quote](#)

BenchChem

Our mission is to be the trusted global source of essential and advanced chemicals, empowering scientists and researchers to drive progress in science and industry.

Contact

Address: 3281 E Guasti Rd
Ontario, CA 91761, United States
Phone: (601) 213-4426
Email: info@benchchem.com

Contact our Ph.D. Support Team for a compatibility check