

Cross-Validation of LI71 Activity with Genetic Models: A Comparative Guide

Author: BenchChem Technical Support Team. **Date:** April 2026

Compound of Interest

Compound Name: *LIN28 inhibitor LI71*

Cat. No.: *B15563764*

[Get Quote](#)

For Researchers, Scientists, and Drug Development Professionals

This guide provides a comprehensive comparison of the pharmacological activity of LI71, a small molecule inhibitor of the RNA-binding protein LIN28, with the phenotypes observed in genetic models of LIN28 manipulation. The objective is to cross-validate the on-target effects of LI71 by demonstrating a convergence of outcomes between chemical and genetic inhibition of the LIN28/let-7 pathway.

Introduction to LI71 and the LIN28/let-7 Pathway

LI71 is a small molecule that has been identified as an inhibitor of the LIN28 protein.^[1] LIN28 is a key regulator of microRNA (miRNA) biogenesis, specifically inhibiting the maturation of the let-7 family of miRNAs.^{[2][3]} The LIN28/let-7 pathway is a critical regulatory axis in developmental timing, pluripotency, and metabolism.^[4] Dysregulation of this pathway is implicated in various cancers, where high LIN28 expression and low let-7 levels are often associated with poor prognosis.^{[2][5]}

LI71 exerts its inhibitory effect by binding to the N-terminal cold-shock domain (CSD) of LIN28, which is crucial for its interaction with the precursor of let-7 (pre-let-7).^[6] By disrupting this interaction, LI71 allows for the processing of pre-let-7 into mature, functional let-7 miRNA.^[6]

Mature let-7 acts as a tumor suppressor by targeting and downregulating the expression of several oncogenes, including MYC, RAS, and HMGA2.[3] Therefore, LI71 represents a promising therapeutic agent for cancers driven by the LIN28/let-7 axis.

Comparative Analysis of LI71 Activity and LIN28 Genetic Models

The cross-validation of LI71's activity is achieved by comparing its effects to the phenotypes observed in genetic models where the Lin28 gene is either knocked out or overexpressed.

In Vitro Cross-Validation

Table 1: Comparison of In Vitro Effects of LI71 and LIN28 Genetic Manipulation

| Feature | LI71 Treatment | LIN28 Knockout/Knockdown | LIN28 Overexpression |
|--|---------------------------------------|---|---|
| Mature let-7 Levels | Increased[1] | Increased[7] | Decreased[7][8] |
| Oncogene Expression (e.g., MYC, HMGA2, SOX2) | Decreased[1] | Decreased[7] | Increased[3] |
| Cancer Cell Stemness | Suppressed colony formation[1] | Suppressed cancer stem cell phenotypes[9] | Promotes cancer stem cell properties[7] |
| Cell Proliferation | Inhibited in LIN28-dependent cells[1] | Reduced proliferation[7] | Increased proliferation[3] |

Cross-Validation in a Genetic Mouse Model

A direct cross-validation of LI71's on-target activity has been demonstrated in mouse embryonic stem cells (mESCs) with a genetic knockout of both Lin28a and Lin28b.

Table 2: LI71 Activity in Lin28a/b Double Knockout mESCs

| Cell Line | Treatment | Effect on Yap1 Protein Levels | Reference |
|---|--------------------|-------------------------------|-----------|
| Lin28a Overexpressing mESCs | LI71 | No change | [10] |
| Lin28a/b Double Knockout (DKO) + exogenous LIN28A | LI71 (100 μ M) | Increased mature let-7 levels | [2] |

These findings indicate that the effects of LI71 are dependent on the presence of LIN28, providing strong evidence for its on-target activity.

Phenotypic Comparison with In Vivo Genetic Models

While direct in vivo studies of LI71 in Lin28 knockout or transgenic mice are not yet extensively published, we can infer the expected outcomes based on the known phenotypes of these genetic models.

Table 3: Comparison of Phenotypes in LIN28 Genetic Mouse Models and Expected Phenotypes with LI71 Treatment

| Phenotype | Lin28a Knockout Mice | Lin28b Knockout Mice | Lin28a Transgenic Mice | Expected Phenotype with LI71 Treatment |
|--------------------|-----------------------------------|---|---|---|
| Body Size | Dwarfism, reduced weight[11] | Normal at birth, later growth defects | Increased body size[7][8] | Potential for reduced tumor growth in cancer models |
| Glucose Metabolism | Defects in glucose metabolism[11] | Aberrations in glucose metabolism in adults[11] | Increased glucose metabolism and insulin sensitivity[7] | Potential modulation of glucose metabolism |
| Puberty Onset | Not reported | Not reported | Delayed[7][8] | To be determined |
| let-7 Levels | Increased in early embryos[11] | Modestly increased in adult tissues | Decreased[8] | Expected to increase let-7 levels in vivo |

The phenotypes observed in Lin28 knockout mice, such as dwarfism and metabolic defects, are consistent with the fundamental role of the LIN28/let-7 pathway in growth and metabolism. [11] Conversely, Lin28a transgenic mice exhibit increased body size and delayed puberty, mirroring findings from human genetic association studies.[7][8] Based on its mechanism of action, chronic treatment with LI71 would be expected to phenocopy aspects of the Lin28 knockout models, particularly in the context of disease, such as inhibiting the growth of LIN28-driven tumors.

Experimental Protocols

Dual-Luciferase Reporter Assay for let-7 Activity

This assay is used to functionally measure the levels of mature let-7 miRNA in cells.

Protocol:

- **Constructs:** A Renilla luciferase reporter vector containing multiple let-7 binding sites in its 3' UTR is co-transfected with a firefly luciferase vector (for normalization) into cells.
- **Cell Treatment:** Cells are treated with LI71 or a vehicle control (e.g., DMSO) for a specified duration (e.g., 48 hours).
- **Lysis and Measurement:** Cells are lysed, and the luciferase activity is measured using a dual-luciferase reporter assay system.
- **Analysis:** The ratio of Renilla to firefly luciferase activity is calculated. A decrease in this ratio indicates an increase in mature let-7 levels, which are binding to the reporter and repressing its translation.

Quantitative Real-Time PCR (qRT-PCR) for Mature let-7 Levels

This method directly quantifies the amount of mature let-7 miRNA.

Protocol:

- **RNA Extraction:** Total RNA, including small RNAs, is extracted from cells or tissues treated with LI71 or vehicle.
- **Reverse Transcription:** A specific stem-loop primer for the mature let-7 miRNA of interest is used for reverse transcription to generate cDNA.
- **qPCR:** The cDNA is then used as a template for quantitative PCR with primers specific for the mature let-7 sequence.
- **Analysis:** The expression levels are normalized to a small RNA internal control (e.g., U6 snRNA).

In Vivo Xenograft Mouse Model for Efficacy Studies

This protocol outlines a general procedure for testing the anti-tumor efficacy of LI71 in a xenograft model.

Protocol:

- Cell Line Selection: Choose a cancer cell line with high LIN28 expression.
- Animal Model: Use immunodeficient mice (e.g., nude or NOD/SCID).
- Tumor Implantation: Subcutaneously inject the cancer cells into the flank of the mice.
- Treatment: Once tumors reach a palpable size (e.g., 100 mm³), randomize mice into treatment and control groups. Administer LI71 (formulated in a suitable vehicle) or vehicle control via an appropriate route (e.g., intraperitoneal injection or oral gavage) at a predetermined dose and schedule.
- Monitoring: Measure tumor volume and body weight regularly (e.g., every 2-3 days).
- Endpoint Analysis: At the end of the study, euthanize the mice and excise the tumors for weight measurement and further analysis (e.g., qRT-PCR for let-7 levels, western blotting for LIN28 and downstream targets).

Visualizations

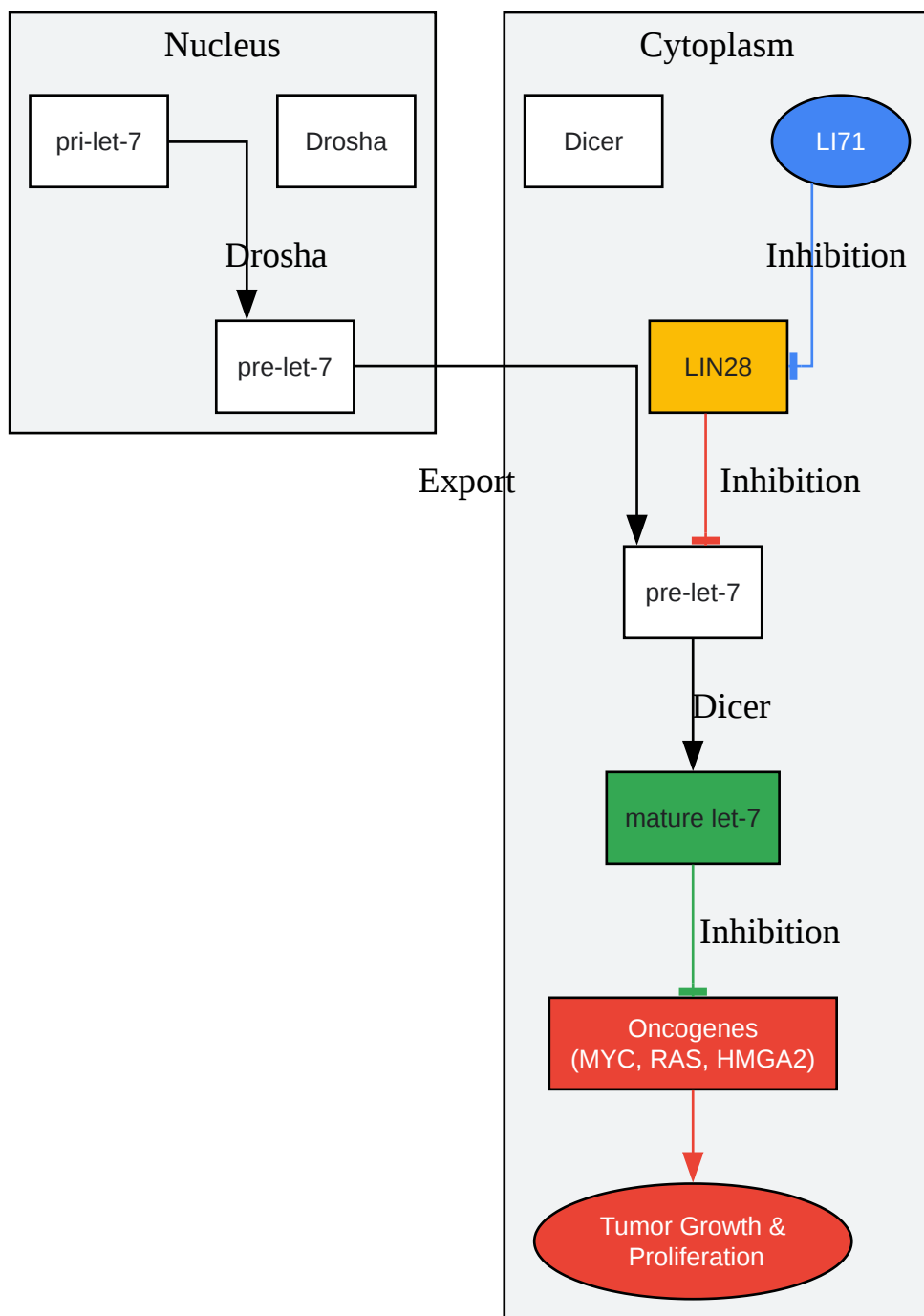

[Click to download full resolution via product page](#)

Caption: The LIN28/let-7 signaling pathway and the mechanism of action of LI71.

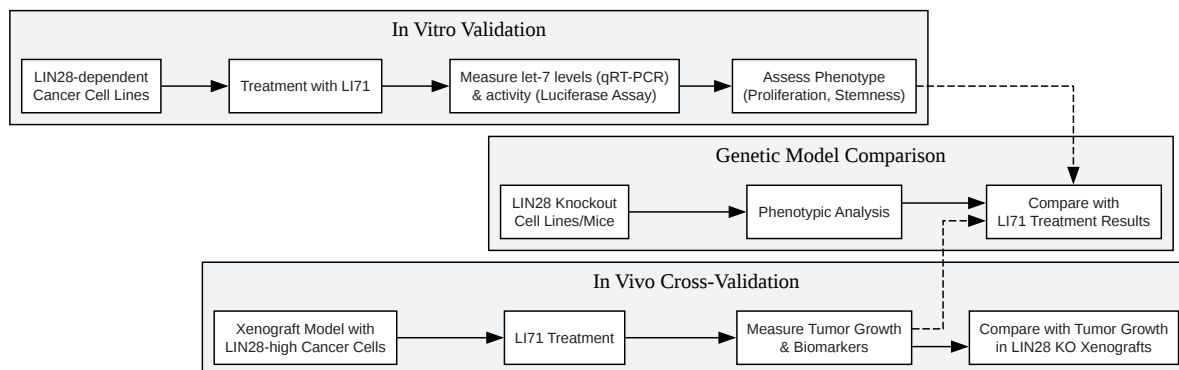

[Click to download full resolution via product page](#)

Caption: Experimental workflow for the cross-validation of LI71 with genetic models.

Conclusion

The available data from in vitro studies and comparisons with the known phenotypes of LIN28 genetic models provide strong evidence for the on-target activity of LI71. The convergence of outcomes between pharmacological inhibition with LI71 and genetic ablation of LIN28—namely, the increase in mature let-7 levels and the suppression of cancer cell proliferation and stemness—validates LI71 as a specific inhibitor of the LIN28/let-7 pathway. Further in vivo studies directly comparing LI71 treatment with LIN28 knockout in mouse models of cancer will be instrumental in fully elucidating its therapeutic potential. This guide provides the foundational data and experimental frameworks for pursuing such investigations.

Need Custom Synthesis?

BenchChem offers custom synthesis for rare earth carbides and specific isotopic labeling.

Email: info@benchchem.com or [Request Quote Online](#).

References

- [1. Discovery of Novel Lin28 Inhibitors to Suppress Cancer Cell Stemness - PMC \[pmc.ncbi.nlm.nih.gov\]](#)
- [2. Frontiers | The LIN28/let-7 Pathway in Cancer \[frontiersin.org\]](#)
- [3. The LIN28/let-7 Pathway in Cancer - PMC \[pmc.ncbi.nlm.nih.gov\]](#)
- [4. Cancer Biology | Daley Laboratory \[daley.hms.harvard.edu\]](#)
- [5. The LIN28/let-7 Pathway in Cancer | Semantic Scholar \[semanticscholar.org\]](#)
- [6. mdpi.com \[mdpi.com\]](#)
- [7. Lin28a transgenic mice manifest size and puberty phenotypes identified in human genetic association studies - PubMed \[pubmed.ncbi.nlm.nih.gov\]](#)
- [8. Lin28a transgenic mice manifest size and puberty phenotypes identified in human genetic association studies - PMC \[pmc.ncbi.nlm.nih.gov\]](#)
- [9. researchgate.net \[researchgate.net\]](#)
- [10. Lin28 Inhibits the Differentiation from Mouse Embryonic Stem Cells to Glial Lineage Cells through Upregulation of Yap1 - PMC \[pmc.ncbi.nlm.nih.gov\]](#)
- [11. Fetal deficiency of Lin28 programs life-long aberrations in growth and glucose metabolism - PMC \[pmc.ncbi.nlm.nih.gov\]](#)
- To cite this document: BenchChem. [Cross-Validation of LI71 Activity with Genetic Models: A Comparative Guide]. BenchChem, [2026]. [Online PDF]. Available at: [\[https://www.benchchem.com/product/b15563764/docs#cross-validation-of-li71-activity-with-genetic-models-a-comparative-guide\]](https://www.benchchem.com/product/b15563764/docs#cross-validation-of-li71-activity-with-genetic-models-a-comparative-guide)

Disclaimer & Data Validity:

The information provided in this document is for Research Use Only (RUO) and is strictly not intended for diagnostic or therapeutic procedures. While BenchChem strives to provide accurate protocols, we make no warranties, express or implied, regarding the fitness of this product for every specific experimental setup.

Technical Support: The protocols provided are for reference purposes. Unsure if this reagent suits your experiment?

Need Industrial/Bulk Grade? [Request Custom Synthesis Quote](#)

BenchChem

Our mission is to be the trusted global source of essential and advanced chemicals, empowering scientists and researchers to drive progress in science and industry.

Contact

Address: 3281 E Guasti Rd

Ontario, CA 91761, United States

Phone: (601) 213-4426

Email: info@benchchem.com

[Contact our Ph.D. Support Team for a compatibility check](#)