

# Application Notes and Protocols for Bedaquiline in Tuberculosis Research

**Author:** BenchChem Technical Support Team. **Date:** April 2026

## Compound of Interest

Compound Name: BAY 249716

Cat. No.: B15563277

[Get Quote](#)

Note: Initial searches for "**BAY 249716**" in the context of tuberculosis studies did not yield specific information. As a relevant and well-documented alternative, these application notes focus on Bedaquiline (Sirturo), a diarylquinoline antimycobacterial agent approved for the treatment of multidrug-resistant tuberculosis (MDR-TB).

## Introduction to Bedaquiline

Bedaquiline is a first-in-class diarylquinoline antibiotic with a unique mechanism of action against *Mycobacterium tuberculosis*. It is a critical component of treatment regimens for MDR-TB and has potent bactericidal and sterilizing activity against both replicating and dormant bacilli.[1][2] Understanding its mechanism of action and having robust protocols to evaluate its efficacy are essential for its effective use and for the development of new anti-tuberculosis agents.

## Mechanism of Action

Bedaquiline's primary target is the F1Fo-ATP synthase, an essential enzyme for energy generation in *M. tuberculosis*. [1][3]

Key aspects of Bedaquiline's mechanism of action include:

- Targeting the F1Fo-ATP Synthase: Bedaquiline specifically binds to the oligomeric c-ring of the Fo subunit of the ATP synthase.[4]
- Inhibition of Proton Translocation: This binding obstructs the proton translocation channel, effectively stalling the rotation of the c-ring.
- Depletion of Cellular ATP: The inhibition of ATP synthase leads to a rapid depletion of intracellular ATP, which is crucial for numerous cellular processes.[5]
- Downstream Effects: The depletion of ATP disrupts various ATP-dependent metabolic processes, including DNA and protein synthesis, and affects nitrogen metabolism.[5] Network analysis has shown that in response to Bedaquiline, *M. tuberculosis* can attempt to rewire its energy metabolism by activating transcription factors such as Rv0324 and Rv0880. [6] The pathogen may also activate the glyoxylate shunt and other pathways to compensate for ATP depletion.[6]

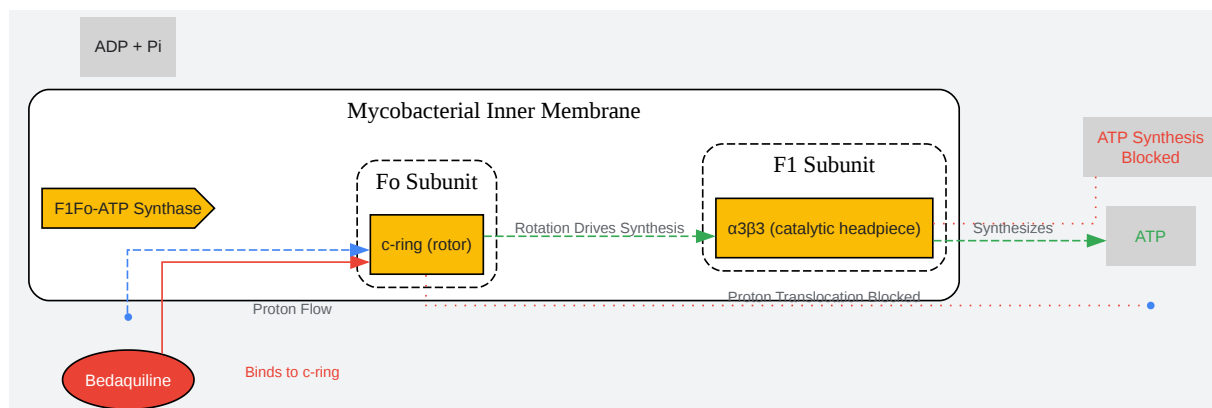

[Click to download full resolution via product page](#)

Bedaquiline binds to the c-ring of ATP synthase, blocking proton translocation and inhibiting ATP synthesis.

## Quantitative Data: In Vitro Activity of Bedaquiline

The in vitro potency of Bedaquiline is typically assessed by determining its Minimum Inhibitory Concentration (MIC), the lowest concentration of the drug that prevents visible growth of *M. tuberculosis*.

M. tuberculosis Strain Type	Methodology	MIC Range (mg/L)	MIC50 (mg/L)	MIC90 (mg/L)	Reference
Drug-susceptible	MGIT 960	Not specified	0.03	Not specified	
Wild-type	MGIT 960 with TB eXiST	Not specified	0.4 (median)	Not specified	
Pan-susceptible & Drug-resistant	REMA	0.0039–0.25	Not specified	Not specified	
Multi-drug resistant (MDR)	Sensititre custom plates	Not specified	0.25	Not specified	
Extensively drug-resistant (XDR)	Sensititre custom plates	Not specified	1	32	

MIC50 and MIC90 represent the concentrations required to inhibit the growth of 50% and 90% of isolates, respectively.

## Experimental Protocols

### Protocol for Determining Minimum Inhibitory Concentration (MIC) using Resazurin Microtiter Assay (REMA)

The REMA is a colorimetric assay that provides a visual determination of bacterial viability. Metabolically active bacteria reduce the blue resazurin dye to pink resorufin.[5]

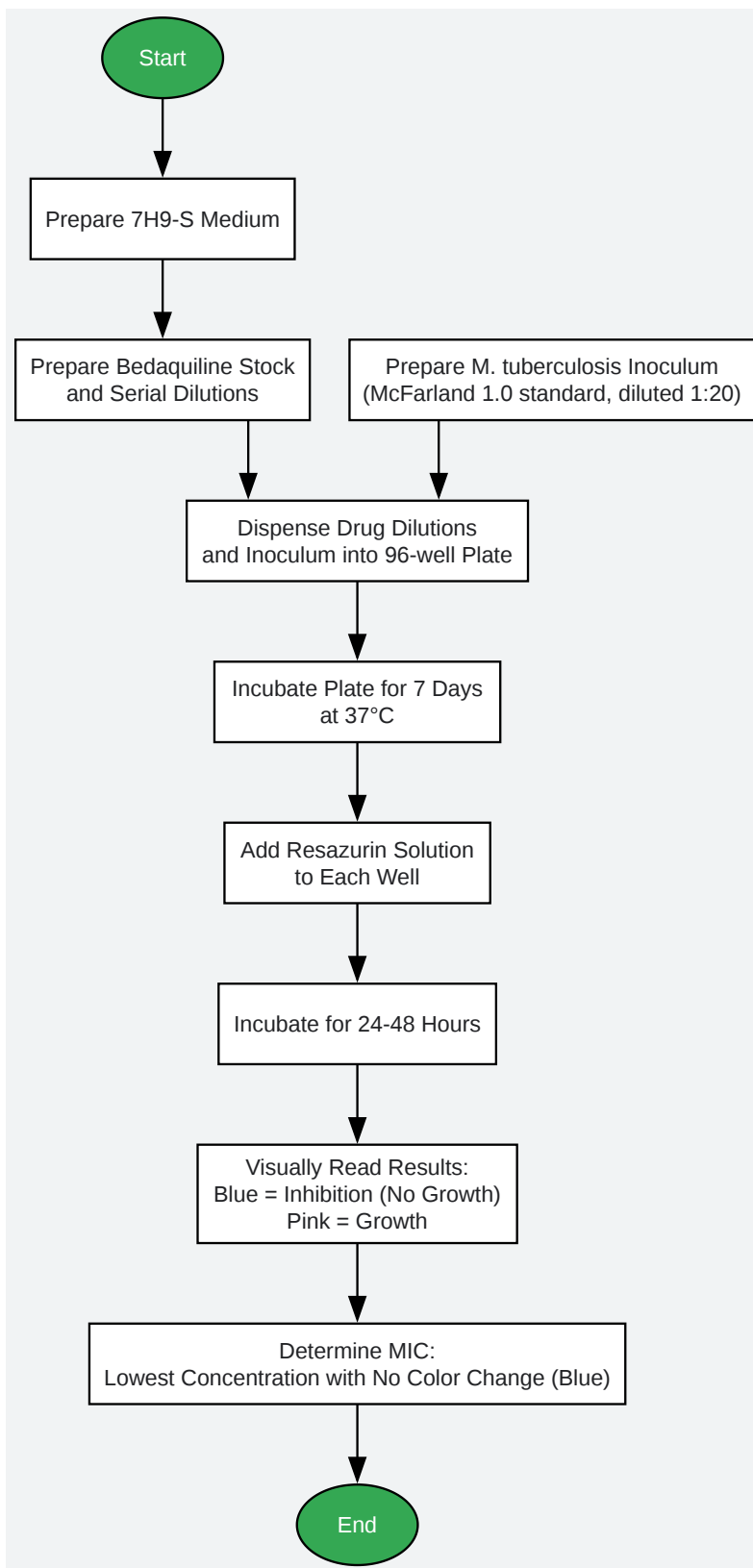

[Click to download full resolution via product page](#)

## Workflow for determining the Minimum Inhibitory Concentration (MIC) using the Resazurin Microtiter Assay (REMA).

### Materials:

- M. tuberculosis isolate (e.g., H37Rv or clinical isolates)
- Middlebrook 7H9 broth supplemented with 0.1% casitone, 10% OADC (oleic acid, albumin, dextrose, catalase), and 0.5% glycerol (7H9-S medium)[1]
- Bedaquiline powder
- Dimethyl sulfoxide (DMSO)
- Sterile 96-well microtiter plates
- Resazurin sodium salt powder
- Sterile distilled water
- McFarland 1.0 turbidity standard

### Procedure:

- Preparation of Bedaquiline Stock and Dilutions:
  - Dissolve Bedaquiline powder in DMSO to prepare a stock solution (e.g., 1 mg/mL).
  - Perform serial twofold dilutions of the stock solution in 7H9-S medium directly in the 96-well plate to achieve the desired final concentration range (e.g., 1.0 to 0.0039 mg/L). The final volume in each well should be 100  $\mu$ L before adding the inoculum.
- Preparation of M. tuberculosis Inoculum:
  - Grow M. tuberculosis in 7H9-S broth to mid-log phase.
  - Adjust the turbidity of the bacterial suspension to match the McFarland 1.0 standard.

- Dilute this suspension 1:20 in 7H9-S medium.
- Inoculation of the Plate:
  - Add 100  $\mu$ L of the diluted bacterial inoculum to each well containing the Bedaquiline dilutions.
  - Include a growth control well (inoculum without drug) and a sterility control well (medium only).
- Incubation:
  - Seal the plate (e.g., with parafilm or a plate sealer) and incubate at 37°C for 7 days.
- Addition of Resazurin:
  - Prepare a 0.02% (w/v) resazurin solution in sterile distilled water and filter-sterilize.
  - After 7 days of incubation, add 30  $\mu$ L of the resazurin solution to each well.
- Final Incubation and Reading:
  - Re-seal the plate and incubate for an additional 24 to 48 hours at 37°C.
  - Visually assess the color change. A blue color indicates no bacterial growth (inhibition), while a pink color indicates bacterial growth.
  - The MIC is the lowest concentration of Bedaquiline that prevents the color change from blue to pink.

## Protocol for Determining Minimum Bactericidal Concentration (MBC)

The MBC is the lowest concentration of an antimicrobial agent required to kill 99.9% of the initial bacterial inoculum.

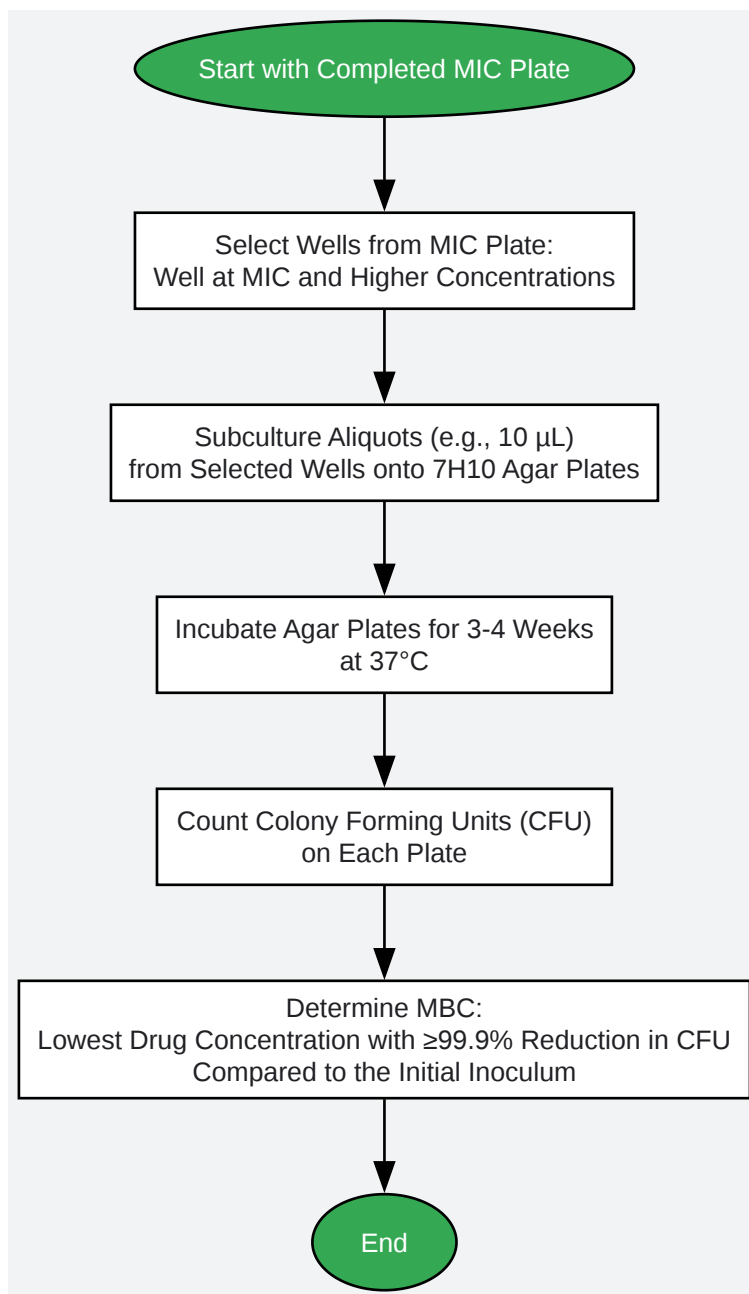

[Click to download full resolution via product page](#)

Workflow for determining the Minimum Bactericidal Concentration (MBC).

Materials:

- Completed REMA plate from the MIC assay
- Middlebrook 7H10 agar plates supplemented with OADC

- Sterile pipette tips and pipettor

Procedure:

- Selection of Wells:
  - Following the determination of the MIC, select the wells corresponding to the MIC value and all higher concentrations of Bedaquiline where no growth was observed (i.e., the wells remained blue).
- Subculturing:
  - Homogenize the contents of each selected well by gentle pipetting.
  - Spot-plate a fixed volume (e.g., 10-20  $\mu$ L) from each of these wells onto a separate, labeled 7H10 agar plate.
  - Also, plate an aliquot from a growth control well (from the MIC plate, diluted to approximate the initial inoculum) to determine the initial CFU count.
- Incubation:
  - Allow the spots to dry completely before inverting the plates.
  - Incubate the agar plates at 37°C for 3 to 4 weeks, or until colonies are clearly visible on the control plate.
- Colony Counting and MBC Determination:
  - Count the number of colonies (CFU) on each plate.
  - The MBC is defined as the lowest concentration of Bedaquiline that results in a  $\geq 99.9\%$  reduction in CFU compared to the initial inoculum count from the growth control.

## Protocol for In Vitro ATP Synthesis Inhibition Assay

This assay measures the effect of Bedaquiline on ATP synthesis in inverted membrane vesicles (IMVs) from a mycobacterial species (e.g., *M. phlei* or *M. smegmatis*). ATP production is

quantified using a luciferin/luciferase-based luminescence assay.[1]

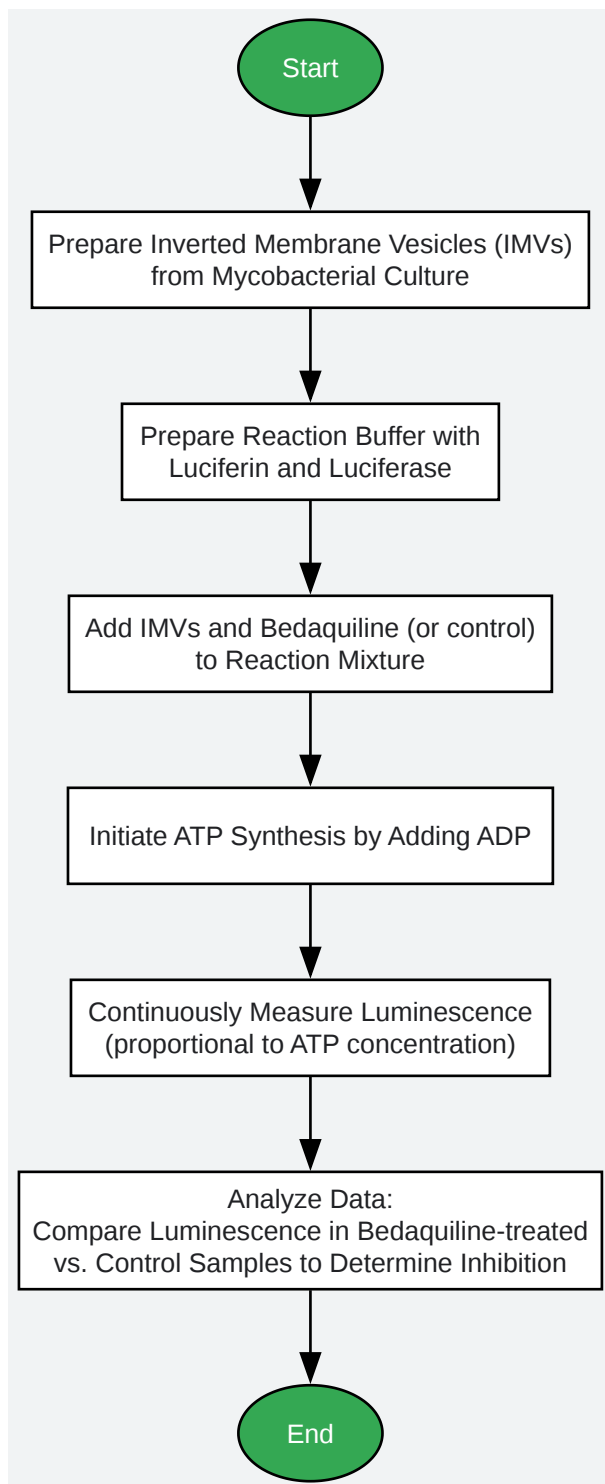

[Click to download full resolution via product page](#)

Workflow for the in vitro ATP synthesis inhibition assay.

#### Materials:

- Mycobacterium phlei or M. smegmatis cell paste
- French press or other cell disruption equipment
- Ultracentrifuge
- Reaction buffer: 20 mM tricine-KOH (pH 7.5), 0.1 M NaCl, 5 mM KPi, 5 mM MgCl<sub>2</sub>[1]
- ADP solution
- Luciferin/Luciferase assay kit
- Bedaquiline
- Luminometer

#### Procedure:

- Preparation of Inverted Membrane Vesicles (IMVs):
  - Resuspend mycobacterial cell paste in a suitable buffer (e.g., 0.15 M NaCl, 0.1 M tricine-KOH pH 7.5, 5 mM MgCl<sub>2</sub>, 10% glycerol).[1]
  - Disrupt the cells using a French press (e.g., three passages at 20,000 psi).[1]
  - Remove unbroken cells by low-speed centrifugation.
  - Pellet the membranes from the supernatant by ultracentrifugation (e.g., 60,000 rpm for 45 minutes).[1]
  - Resuspend the IMV pellet in buffer to a final concentration of approximately 5 mg/mL.[1]
- ATP Synthesis Assay:
  - In a luminometer cuvette, combine the reaction buffer, 50 µg of IMVs, luciferin, and luciferase.

- Add Bedaquiline at various concentrations to different cuvettes. Include a no-drug control (DMSO vehicle) and other controls like an uncoupler (CCCP) or a known ATP synthase inhibitor (DCCD).[1]
- Equilibrate the mixture for a few minutes.
- Initiate the ATP synthesis reaction by adding ADP (e.g., to a final concentration of 50  $\mu$ M). [1]
- Data Acquisition and Analysis:
  - Immediately begin monitoring the luminescence signal over time. An increase in luminescence corresponds to ATP production.
  - Compare the rate of ATP synthesis in the presence of Bedaquiline to the no-drug control.
  - Plot the percentage of inhibition against the Bedaquiline concentration to determine the IC50 value (the concentration that causes 50% inhibition of ATP synthesis).

#### Need Custom Synthesis?

BenchChem offers custom synthesis for rare earth carbides and specific isotopic labeling.

Email: [info@benchchem.com](mailto:info@benchchem.com) or [Request Quote Online](#).

## References

- 1. Structure of the mycobacterial ATP synthase Fo rotor ring in complex with the anti-TB drug bedaquiline - PMC [[pmc.ncbi.nlm.nih.gov](https://pubmed.ncbi.nlm.nih.gov/)]
- 2. A simple assay for inhibitors of mycobacterial oxidative phosphorylation - PubMed [[pubmed.ncbi.nlm.nih.gov](https://pubmed.ncbi.nlm.nih.gov/)]
- 3. Mycobacterium tuberculosis F-ATP Synthase Inhibitors and Targets - PMC [[pmc.ncbi.nlm.nih.gov](https://pubmed.ncbi.nlm.nih.gov/)]
- 4. Cell death paradigms in the pathogenesis of Mycobacterium tuberculosis infection - PMC [[pmc.ncbi.nlm.nih.gov](https://pubmed.ncbi.nlm.nih.gov/)]
- 5. ATP stimulates human macrophages to kill intracellular virulent Mycobacterium tuberculosis via calcium-dependent phagosome-lysosome fusion - PubMed

[\[pubmed.ncbi.nlm.nih.gov\]](https://pubmed.ncbi.nlm.nih.gov)

- [6. researchgate.net \[researchgate.net\]](https://researchgate.net)
- To cite this document: BenchChem. [Application Notes and Protocols for Bedaquiline in Tuberculosis Research]. BenchChem, [2026]. [Online PDF]. Available at: [\[https://www.benchchem.com/product/b15563277/docs#application-notes-and-protocols-for-bedaquiline-in-tuberculosis-research\]](https://www.benchchem.com/product/b15563277/docs#application-notes-and-protocols-for-bedaquiline-in-tuberculosis-research)

---

### Disclaimer & Data Validity:

The information provided in this document is for Research Use Only (RUO) and is strictly not intended for diagnostic or therapeutic procedures. While BenchChem strives to provide accurate protocols, we make no warranties, express or implied, regarding the fitness of this product for every specific experimental setup.

**Technical Support:** The protocols provided are for reference purposes. Unsure if this reagent suits your experiment?

**Need Industrial/Bulk Grade?** [Request Custom Synthesis Quote](#)

## BenchChem

Our mission is to be the trusted global source of essential and advanced chemicals, empowering scientists and researchers to drive progress in science and industry.

### Contact

Address: 3281 E Guasti Rd  
Ontario, CA 91761, United States  
Phone: (601) 213-4426  
Email: [info@benchchem.com](mailto:info@benchchem.com)

[Contact our Ph.D. Support Team for a compatibility check](#)