

Application Notes and Protocols: Synthesis of Pradimicin L Derivatives

Author: BenchChem Technical Support Team. **Date:** April 2026

Compound of Interest

Compound Name: Pradimicin L

Cat. No.: B15563504

[Get Quote](#)

For Researchers, Scientists, and Drug Development Professionals

Introduction

Pradimicins are a class of benzo[a]naphthacenequinone antibiotics known for their potent antifungal and antiviral activities.[1] Their unique mechanism of action, which involves binding to D-mannose residues on the fungal cell wall in a calcium-dependent manner, sets them apart from many existing antifungal agents.[1][2] **Pradimicin L**, a congener of Pradimicin A, possesses a distinct D-glucosyl-D-thomosamine moiety at the C-5 position. The development of **Pradimicin L** derivatives is a promising avenue for the discovery of new therapeutic agents with improved efficacy, solubility, and pharmacokinetic profiles.

These application notes provide a comprehensive overview of the methods for synthesizing **Pradimicin L** derivatives. The protocols described herein are based on established synthetic modifications of the pradimicin scaffold and can be adapted for the specific derivatization of **Pradimicin L**.

I. General Strategies for the Synthesis of Pradimicin L Derivatives

The synthesis of **Pradimicin L** derivatives can be broadly categorized into three main strategies, focusing on the modification of distinct structural components of the molecule:

- Modification of the Aglycone: Alterations to the benzo[a]naphthacenequinone core.
- Modification of the Sugar Moiety: Changes to the D-glucosyl-D-thomosamine group.
- Modification of the D-Alanine Moiety: Derivatization of the amino acid side chain.

A general workflow for the synthesis and evaluation of **Pradimicin L** derivatives is outlined below.

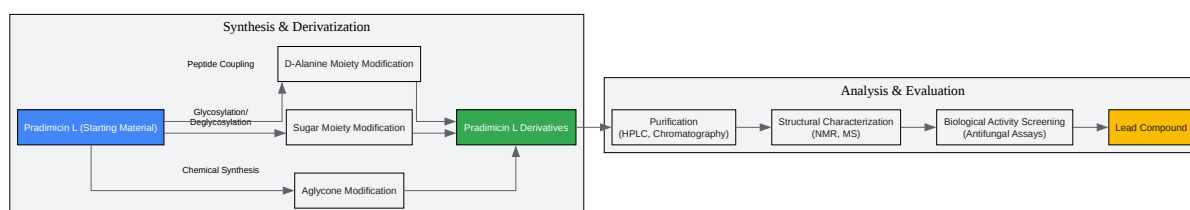

[Click to download full resolution via product page](#)

Caption: General workflow for the synthesis and evaluation of **Pradimicin L** derivatives.

II. Experimental Protocols

The following protocols are generalized methods for the synthesis of pradimicin derivatives and can be adapted for **Pradimicin L**. Researchers should optimize these conditions for their specific target molecules.

Protocol 1: Modification of the Aglycone at the C-11 Position

Modification at the C-11 position of the aglycone has been shown to be a viable strategy for creating active derivatives.[3] This protocol is adapted from the synthesis of Pradimicin A and T1 derivatives.

Objective: To synthesize 11-O-alkyl derivatives of **Pradimicin L**.

Materials:

- 11-hydroxy-**Pradimicin L** (starting material, may require prior demethylation of **Pradimicin L**)
- Alkyl halide (e.g., ethyl iodide, fluoroethyl iodide)
- Potassium carbonate (K_2CO_3)
- N,N-Dimethylformamide (DMF)
- Ethyl acetate (EtOAc)
- Brine
- Anhydrous sodium sulfate (Na_2SO_4)
- Silica gel for column chromatography

Procedure:

- Dissolve 11-hydroxy-**Pradimicin L** in anhydrous DMF.
- Add an excess of potassium carbonate to the solution.
- Add the desired alkyl halide (1.5-2.0 equivalents) to the reaction mixture.
- Stir the reaction mixture at room temperature for 12-24 hours, monitoring the reaction progress by thin-layer chromatography (TLC).
- Upon completion, quench the reaction by adding water.
- Extract the product with ethyl acetate.

- Wash the organic layer sequentially with water and brine.
- Dry the organic layer over anhydrous sodium sulfate and concentrate under reduced pressure.
- Purify the crude product by silica gel column chromatography to obtain the desired 11-O-alkyl **Pradimicin L** derivative.

Protocol 2: Modification of the Sugar Moiety at the C4'-Amino Group

The C4'-amino group of the sugar moiety is a key site for modification to improve properties such as water solubility.[4] This protocol is based on the synthesis of C4'-N-acyl and C4'-N-alkyl derivatives of Pradimicins A and C.

Objective: To synthesize C4'-N-acyl derivatives of **Pradimicin L**.

Materials:

- **Pradimicin L**
- N,O-Bis(trimethylsilyl)acetamide (BSA)
- Pyridine
- Acylating agent (e.g., acid chloride or anhydride)
- Dichloromethane (DCM)
- Methanol (MeOH)
- Silica gel for column chromatography

Procedure:

- Suspend **Pradimicin L** in a mixture of pyridine and DCM.

- Add BSA to the suspension and stir at room temperature until the solution becomes clear (indicating silylation is complete).
- Cool the reaction mixture to 0 °C.
- Add the acylating agent dropwise to the cooled solution.
- Allow the reaction to warm to room temperature and stir for 4-12 hours, monitoring by TLC.
- Quench the reaction by adding methanol.
- Concentrate the reaction mixture under reduced pressure.
- Purify the residue by silica gel column chromatography to yield the C4'-N-acyl **Pradimicin L** derivative.

Protocol 3: Modification of the D-Alanine Moiety

The D-alanine moiety can be exchanged with other amino acids or its carboxyl group can be modified to produce amide derivatives with retained antifungal activity.^{[5][6]}

Objective: To synthesize amide derivatives of the D-alanine moiety of **Pradimicin L**.

Materials:

- **Pradimicin L**
- Amine of choice (R-NH₂)
- 1-Ethyl-3-(3-dimethylaminopropyl)carbodiimide (EDC)
- 1-Hydroxybenzotriazole (HOBt)
- N,N-Dimethylformamide (DMF)
- Dichloromethane (DCM)
- Saturated aqueous sodium bicarbonate (NaHCO₃)

- Brine
- Anhydrous sodium sulfate (Na_2SO_4)
- Silica gel for column chromatography

Procedure:

- Dissolve **Pradimicin L** in anhydrous DMF.
- Add HOBt and EDC to the solution and stir for 15 minutes at room temperature.
- Add the desired amine to the reaction mixture.
- Stir the reaction at room temperature for 12-24 hours, monitoring by TLC.
- Dilute the reaction mixture with DCM.
- Wash the organic layer sequentially with saturated aqueous NaHCO_3 , water, and brine.
- Dry the organic layer over anhydrous sodium sulfate and concentrate under reduced pressure.
- Purify the crude product by silica gel column chromatography to obtain the D-alanine amide derivative of **Pradimicin L**.

III. Quantitative Data on Pradimicin Derivatives

The following tables summarize the antifungal activity of various pradimicin derivatives. While specific data for **Pradimicin L** derivatives is limited in the public domain, the data for closely related analogs provide valuable insights into structure-activity relationships.

Table 1: In Vitro Antifungal Activity (MIC, $\mu\text{g}/\text{mL}$) of Pradimicin A and its Derivatives

Compound	Candida albicans	Cryptococcus neoformans	Aspergillus fumigatus	Reference
Pradimicin A	3.13 - 12.5	3.13 - 6.25	6.25 - 25	[7]
BMS-181184	2 - 8	≤ 8	≤ 8	[1]
11-O-ethyl-PRM T1	1.56	3.13	6.25	[3]
4'-N-formyl-PRM A	6.25	6.25	12.5	[4]
D-Serine analog	3.13	3.13	6.25	[5]

Table 2: Characterization Data for Selected Pradimicin Analogs

Compound	Molecular Formula	Mass Spectrometry (m/z)	Key ¹ H NMR Signals (ppm)	Reference
Pradimicin S	C ₄₁ H ₄₆ N ₂ O ₂₃ S	[M+H] ⁺ (FAB-MS)	Not detailed in abstract	[8]
Pradimicin Q	Not specified	Not specified	Not detailed in abstract	[9]
11-demethoxy-PRM A	C ₃₅ H ₃₆ N ₂ O ₁₃	693.2245 [M+H] ⁺	Not detailed in abstract	[3]
4'-N-formyl-PRM A	C ₃₆ H ₃₆ N ₂ O ₁₅	753.2144 [M+H] ⁺	Not detailed in abstract	[4]

IV. Signaling Pathways and Mechanisms

Biosynthetic Pathway of Pradimicins

The biosynthesis of pradimicins is a complex process involving a type II polyketide synthase (PKS) and a series of tailoring enzymes.[10] The pathway involves the assembly of a

polyketide chain, followed by cyclization and a series of post-PKS modifications including hydroxylation and glycosylation.

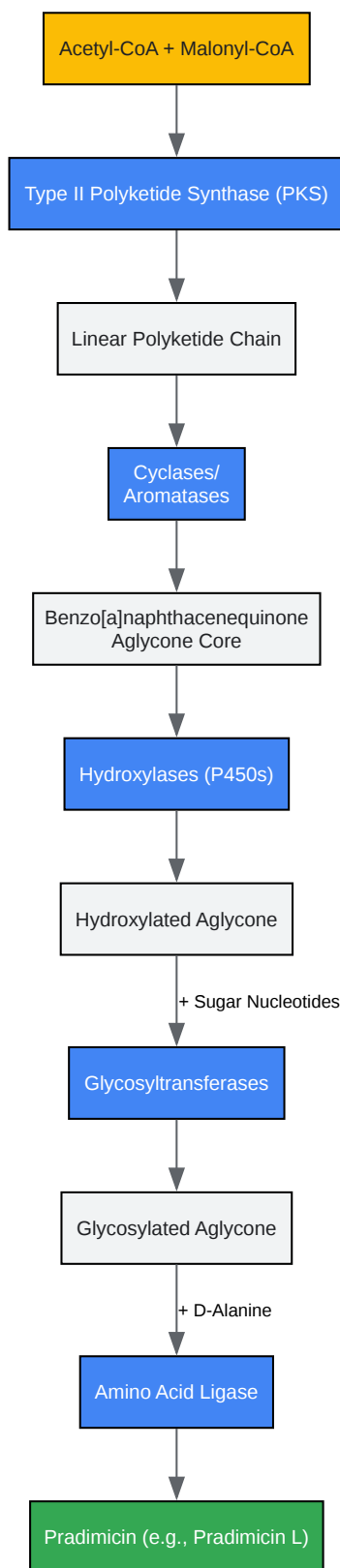

[Click to download full resolution via product page](#)

Caption: Simplified biosynthetic pathway of pradimicins.

Mechanism of Antifungal Action

The antifungal activity of pradimicins stems from their ability to bind to D-mannose residues on the surface of fungal cells.[1][11] This interaction is dependent on the presence of calcium ions and leads to the formation of a ternary complex, which disrupts the fungal cell membrane integrity, ultimately causing cell death.[2][11]

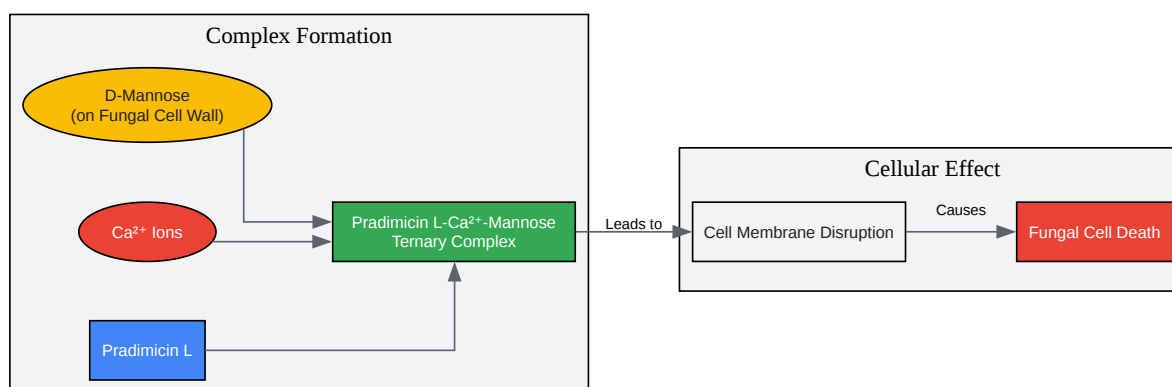

[Click to download full resolution via product page](#)

Caption: Mechanism of antifungal action of **Pradimicin L**.

V. Conclusion

The synthesis of **Pradimicin L** derivatives offers a fertile ground for the development of novel antifungal agents. By leveraging the synthetic strategies outlined in these application notes, researchers can explore the vast chemical space around the pradimicin scaffold. The provided protocols for modification of the aglycone, sugar moiety, and D-alanine residue serve as a starting point for the generation of diverse libraries of **Pradimicin L** analogs. Subsequent screening of these derivatives for their biological activity will be crucial in identifying lead

compounds with enhanced therapeutic potential. The unique mechanism of action of pradimicins makes this class of compounds a particularly attractive target for overcoming existing antifungal drug resistance.

Need Custom Synthesis?

BenchChem offers custom synthesis for rare earth carbides and specific isotopic labeling.

Email: info@benchchem.com or [Request Quote Online](#).

References

- 1. Pradimicins: a novel class of broad-spectrum antifungal compounds - PubMed [pubmed.ncbi.nlm.nih.gov]
- 2. Activity and Mechanism of Action of Antifungal Peptides from Microorganisms: A Review - PMC [pmc.ncbi.nlm.nih.gov]
- 3. Synthesis and antifungal activity of pradimicin derivatives. Modifications on the aglycone part - PubMed [pubmed.ncbi.nlm.nih.gov]
- 4. Synthesis and antifungal activities of pradimicin derivatives, modification at C4'-position - PubMed [pubmed.ncbi.nlm.nih.gov]
- 5. Synthesis and antifungal activities of alanine-exchanged analogs of pradimicin A - PubMed [pubmed.ncbi.nlm.nih.gov]
- 6. Synthesis and antifungal activities of pradimicin A derivatives modification of the alanine moiety - PubMed [pubmed.ncbi.nlm.nih.gov]
- 7. PRADIMICINS A, B AND C: NEW ANTIFUNGAL ANTIBIOTICS [jstage.jst.go.jp]
- 8. Pradimicin S, a new pradimicin analog. II. Isolation and structure elucidation - PubMed [pubmed.ncbi.nlm.nih.gov]
- 9. Pradimicin Q, a new pradimicin aglycone, with alpha-glucosidase inhibitory activity - PubMed [pubmed.ncbi.nlm.nih.gov]
- 10. Synergistic Actions of Tailoring Enzymes in Pradimicin Biosynthesis - PMC [pmc.ncbi.nlm.nih.gov]
- 11. Studies on the mode of antifungal action of pradimicin antibiotics. III. Spectrophotometric sequence analysis of the ternary complex formation of BMY-28864 with D-mannopyranoside and calcium - PubMed [pubmed.ncbi.nlm.nih.gov]

- To cite this document: BenchChem. [Application Notes and Protocols: Synthesis of Pradimicin L Derivatives]. BenchChem, [2026]. [Online PDF]. Available at: [<https://www.benchchem.com/product/b15563504/docs#application-notes-and-protocols-synthesis-of-pradimicin-l-derivatives>]

Disclaimer & Data Validity:

The information provided in this document is for Research Use Only (RUO) and is strictly not intended for diagnostic or therapeutic procedures. While BenchChem strives to provide accurate protocols, we make no warranties, express or implied, regarding the fitness of this product for every specific experimental setup.

Technical Support: The protocols provided are for reference purposes. Unsure if this reagent suits your experiment?

Need Industrial/Bulk Grade? [Request Custom Synthesis Quote](#)

BenchChem

Our mission is to be the trusted global source of essential and advanced chemicals, empowering scientists and researchers to drive progress in science and industry.

Contact

Address: 3281 E Guasti Rd
Ontario, CA 91761, United States
Phone: (601) 213-4426
Email: info@benchchem.com

[Contact our Ph.D. Support Team for a compatibility check](#)