

# Application Notes and Protocols for Investigating Isariin D in Insect Detoxification Pathways

**Author:** BenchChem Technical Support Team. **Date:** April 2026

## Compound of Interest

Compound Name: *Isariin D*  
Cat. No.: *B15561028*

[Get Quote](#)

For Researchers, Scientists, and Drug Development Professionals

## Introduction

**Isariin D**, a cyclodepsipeptide isolated from the entomopathogenic fungus *Isaria felina*, has demonstrated notable insecticidal properties. Cyclodepsipeptides represent a class of bioactive compounds with a range of biological effects, including antimicrobial, antiviral, and insecticidal activities. Within this class, compounds such as Destruxin A have been shown to modulate the insect immune system and, significantly, to interfere with detoxification pathways. Specifically, studies on the whitefly, *Bemisia tabaci*, have revealed that Destruxin A can lead to the downregulation of numerous detoxification genes, including a substantial number of cytochrome P450 (CYP) genes.

Given the structural and functional similarities among cyclodepsipeptides, there is a strong rationale for investigating **Isariin D** as a potential modulator of insect detoxification mechanisms. Understanding how **Isariin D** interacts with key detoxification enzyme systems—such as cytochrome P450 monooxygenases (P450s), glutathione S-transferases (GSTs), and carboxylesterases (CCEs)—could unveil novel strategies for insect pest management. These

enzymes are crucial for insects to metabolize and develop resistance to both natural plant defenses and synthetic insecticides.

These application notes provide a comprehensive framework for researchers to explore the effects of **Isariin D** on insect detoxification pathways. The following sections detail protocols for insect rearing, bioassays, enzymatic assays, and gene expression analysis, enabling a thorough investigation of **Isariin D**'s mechanism of action.

## Data Presentation

As direct quantitative data for **Isariin D**'s effect on insect detoxification enzymes is the subject of the proposed investigation, the following table is presented as a template for researchers to populate with their experimental findings.

Enzyme/Gene	Insect Species	Isariin D Concentration	Effect (e.g., IC50, % Inhibition, Fold Change in Expression)	Reference
Cytochrome P450 Activity	Galleria mellonella	e.g., 10 $\mu$ M	Data to be determined	(Your Study)
Glutathione S-Transferase Activity	Galleria mellonella	e.g., 10 $\mu$ M	Data to be determined	(Your Study)
Carboxylesterase Activity	Galleria mellonella	e.g., 10 $\mu$ M	Data to be determined	(Your Study)
CYP6A1 Gene Expression	Galleria mellonella	e.g., 10 $\mu$ M	Data to be determined	(Your Study)
GST-theta Gene Expression	Galleria mellonella	e.g., 10 $\mu$ M	Data to be determined	(Your Study)

## Experimental Protocols

### Insect Rearing: *Galleria mellonella* (Greater Wax Moth)

*Galleria mellonella* larvae are a suitable model for these studies due to their widespread use in insect toxicology and immunology research.

Materials:

- Glass or plastic containers (1-2 L) with ventilated lids
- Artificial diet (e.g., a mixture of beeswax, pollen, bran, yeast, and glycerol)
- Filter paper
- Incubator set to 28-30°C and 60-70% relative humidity

Protocol:

- Prepare the artificial diet and place it at the bottom of the rearing containers.
- Introduce *G. mellonella* eggs or early-instar larvae onto the diet.
- Line the top of the container with folded filter paper to provide a pupation site.
- Maintain the containers in the incubator in darkness.
- Larvae will be ready for experiments in the final instar stage (approximately 2-3 cm in length).

## Insecticidal Bioassay with Isariin D

This protocol determines the toxicity of **Isariin D** to *G. mellonella* larvae.

Materials:

- Final instar *G. mellonella* larvae
- **Isariin D** stock solution (dissolved in a suitable solvent, e.g., DMSO)
- Micro-applicator or fine-gauge needle
- Petri dishes with filter paper

- Artificial diet

Protocol:

- Prepare serial dilutions of **Isariin D** in an appropriate solvent.
- Select healthy, uniform-sized final instar larvae.
- Apply a precise volume (e.g., 1  $\mu$ L) of the **Isariin D** solution topically to the dorsal thorax of each larva or inject it into the hemocoel. A control group should be treated with the solvent alone.
- Place the treated larvae in Petri dishes containing a small amount of artificial diet.
- Incubate at 28-30°C.
- Record mortality at 24, 48, and 72 hours post-treatment.
- Calculate the median lethal dose (LD50) using probit analysis.

## Enzyme Activity Assays

These assays measure the activity of key detoxification enzymes in insect tissues following exposure to **Isariin D**.

### 3.1. Preparation of Insect Homogenate/Microsomes:

- Homogenize whole larvae or dissected midguts in ice-cold phosphate buffer (pH 7.4).
- For P450 assays, prepare microsomes by differential centrifugation:
  - Centrifuge the homogenate at 10,000 x g for 20 minutes at 4°C to remove cell debris.
  - Centrifuge the resulting supernatant at 100,000 x g for 60 minutes at 4°C.
  - Resuspend the microsomal pellet in phosphate buffer.
- Determine the protein concentration of the homogenate or microsomal fraction using a standard method (e.g., Bradford assay).

### 3.2. Cytochrome P450 Activity Assay (e.g., EROD assay):

- To a microplate well, add the microsomal preparation, NADPH, and buffer.
- Initiate the reaction by adding the substrate (e.g., 7-ethoxyresorufin).
- Measure the fluorescence of the product (resorufin) over time using a microplate reader.
- Calculate P450 activity as pmol of product formed per minute per mg of protein.

### 3.3. Glutathione S-Transferase (GST) Activity Assay:

- To a microplate well, add the insect homogenate supernatant, reduced glutathione (GSH), and buffer.
- Start the reaction by adding the substrate (e.g., 1-chloro-2,4-dinitrobenzene, CDNB).
- Monitor the increase in absorbance at 340 nm over time.
- Calculate GST activity as nmol of CDNB-GSH conjugate formed per minute per mg of protein.

## Gene Expression Analysis by Quantitative PCR (qPCR)

This protocol quantifies the expression levels of detoxification genes in response to **Isariin D** treatment.

#### Materials:

- *G. mellonella* larvae treated with **Isariin D** (sub-lethal dose) and control larvae
- RNA extraction kit
- cDNA synthesis kit
- qPCR instrument and reagents (e.g., SYBR Green)
- Primers for target detoxification genes (e.g., specific CYPs, GSTs) and a reference gene (e.g., actin)

Protocol:

- Expose larvae to a sub-lethal concentration of **Isariin D** for a defined period (e.g., 24 hours).
- Extract total RNA from whole larvae or specific tissues (e.g., midgut, fat body).
- Synthesize cDNA from the extracted RNA.
- Perform qPCR using gene-specific primers.
- Analyze the qPCR data using the  $\Delta\Delta C_t$  method to determine the relative fold change in gene expression in **Isariin D**-treated larvae compared to controls.

## Visualizations

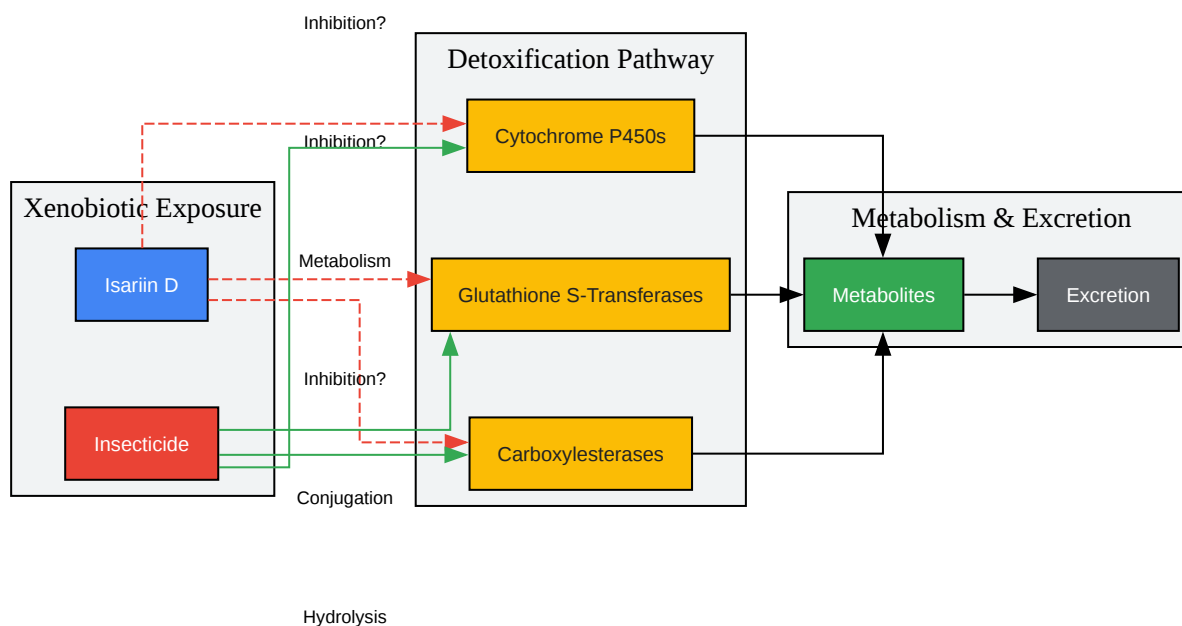

[Click to download full resolution via product page](#)

Caption: Proposed interaction of **Isariin D** with insect detoxification pathways.

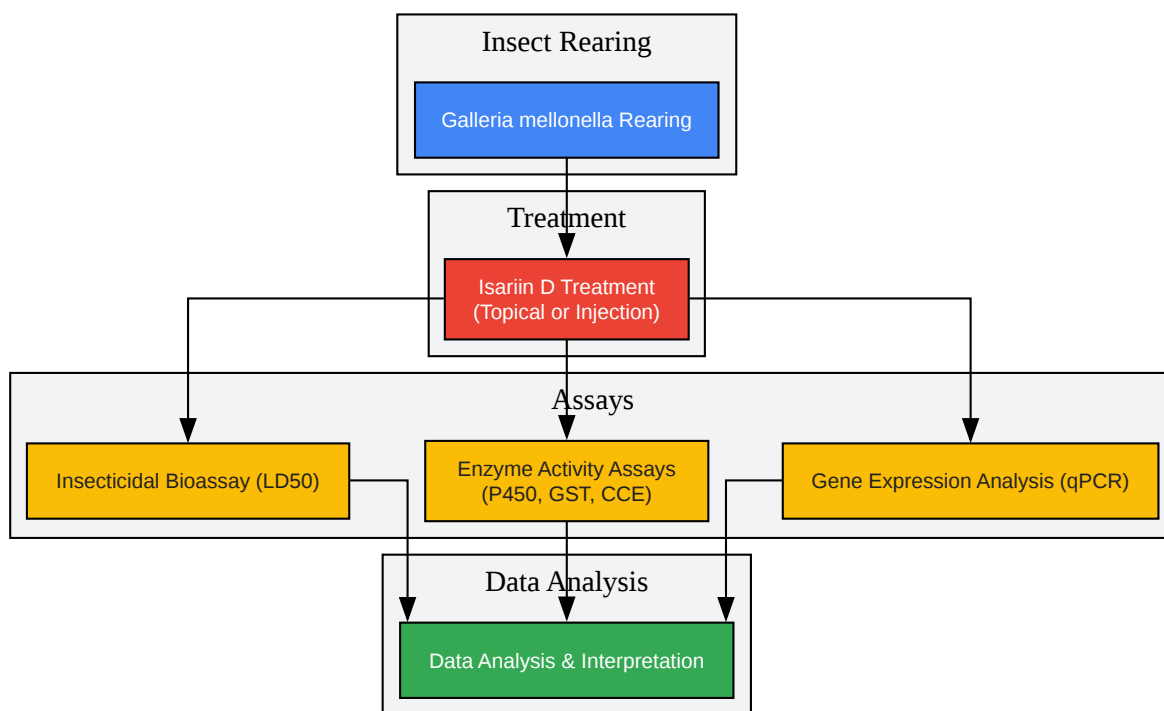

[Click to download full resolution via product page](#)

Caption: Workflow for studying **Isariin D**'s effects on insect detoxification.

- To cite this document: BenchChem. [Application Notes and Protocols for Investigating Isariin D in Insect Detoxification Pathways]. BenchChem, [2026]. [Online PDF]. Available at: [\[https://www.benchchem.com/product/b15561028/docs#application-notes-and-protocols-for-investigating-isariin-d-in-insect-detoxification-pathways\]](https://www.benchchem.com/product/b15561028/docs#application-notes-and-protocols-for-investigating-isariin-d-in-insect-detoxification-pathways)

#### Disclaimer & Data Validity:

The information provided in this document is for Research Use Only (RUO) and is strictly not intended for diagnostic or therapeutic procedures. While BenchChem strives to provide accurate protocols, we make no warranties, express or implied, regarding the fitness of this product for every specific experimental setup.

**Technical Support:** The protocols provided are for reference purposes. Unsure if this reagent suits your experiment?

**Need Industrial/Bulk Grade?** [Request Custom Synthesis Quote](#)

## BenchChem

Our mission is to be the trusted global source of essential and advanced chemicals, empowering scientists and researchers to drive progress in science and industry.

### Contact

Address: 3281 E Guasti Rd  
Ontario, CA 91761, United States  
Phone: (601) 213-4426  
Email: [info@benchchem.com](mailto:info@benchchem.com)

[Contact our Ph.D. Support Team for a compatibility check](#)