

Technical Support Center: Enhancing Cell Permeability of Nitidanib Derivatives

Author: BenchChem Technical Support Team. **Date:** April 2026

Compound of Interest

Compound Name: Nitidanin
Cat. No.: B15560970

[Get Quote](#)

Welcome to the technical support center for researchers, scientists, and drug development professionals working with Nitidanib and its derivatives. This resource provides troubleshooting guidance and frequently asked questions (FAQs) to address challenges related to poor cell permeability, a critical factor in the efficacy of this class of compounds.

Frequently Asked Questions (FAQs)

Q1: Why are my Nitidanib derivatives showing low cell permeability in in-vitro assays?

Poor cell permeability of Nitidanib derivatives can be attributed to several factors:

- **Physicochemical Properties:** Nitidanib itself has low aqueous solubility at neutral pH.^{[1][2][3]} Derivatives that are highly lipophilic may be retained in the cell membrane, while highly hydrophilic derivatives may not efficiently cross the lipid bilayer.
- **P-glycoprotein (P-gp) Efflux:** Nitidanib is a known substrate of the P-glycoprotein (P-gp) efflux pump.^{[1][2]} This transporter actively removes the compound from the cell, reducing its intracellular concentration. It is highly probable that structurally similar derivatives are also P-gp substrates.

- **Low Aqueous Solubility:** Compounds with low solubility may precipitate in the assay medium, reducing the concentration available for absorption.

Q2: How can I improve the cell permeability of my Nitidanib derivatives?

Several strategies can be employed to enhance the cell permeability of your compounds:

- **Structural Modification:**
 - **Prodrug Approach:** Masking polar functional groups with lipophilic moieties can increase passive diffusion across the cell membrane. These lipophilic groups are later cleaved by intracellular enzymes to release the active drug.
 - **Optimize Lipophilicity:** Aim for a balanced lipophilicity (logP value). Very high lipophilicity can lead to poor solubility and membrane sequestration.
 - **Reduce Hydrogen Bond Donors/Acceptors:** Minimizing the number of hydrogen bond donors and acceptors can decrease the desolvation penalty for membrane transit.
- **Formulation Strategies:**
 - **Self-Microemulsifying Drug Delivery Systems (SMEDDS):** These systems can improve the solubility and permeability of poorly soluble drugs.[4] A study showed that a SMEDDS formulation of Nitidanib increased its permeability in a Caco-2 cell model by 2.8-fold.[4]
 - **Cyclodextrin Complexation:** Complexing the drug with cyclodextrins can enhance its solubility and reduce P-gp efflux.[5]
- **Inhibition of Efflux Pumps:** Co-administration with a known P-gp inhibitor, such as verapamil, can increase the intracellular concentration of your derivative in in vitro experiments.[6]

Q3: What are the key signaling pathways targeted by Nitidanib that I should be aware of during my experiments?

Nitidanib is a multi-targeted tyrosine kinase inhibitor that primarily blocks the following signaling pathways:

- Vascular Endothelial Growth Factor Receptor (VEGFR) 1-3
- Fibroblast Growth Factor Receptor (FGFR) 1-3
- Platelet-Derived Growth Factor Receptor (PDGFR) α and β

Inhibition of these receptors blocks downstream signaling cascades, including the Akt and ERK pathways, which are involved in cell proliferation, migration, and angiogenesis.[1][7][8]

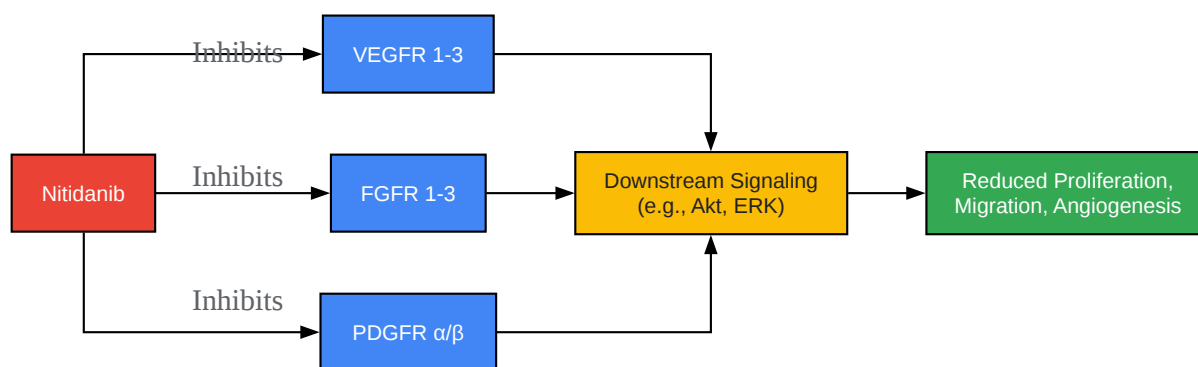

[Click to download full resolution via product page](#)

Caption: Signaling pathways inhibited by Nitidanib.

Troubleshooting Guides

Guide 1: Inconsistent Results in Caco-2 Permeability Assay

Observed Problem	Potential Cause	Troubleshooting Step
High variability in apparent permeability (P _{app}) values between wells.	Inconsistent cell monolayer integrity.	<ol style="list-style-type: none"> 1. Measure Transepithelial Electrical Resistance (TEER) for each well before the experiment. Ensure values are within the acceptable range for your lab (typically >200 Ω·cm²). [6][9] 2. Perform a Lucifer Yellow permeability test on a subset of wells to confirm tight junction formation. A P_{app} for Lucifer Yellow of <math>1.0 \times 10^{-6}</math> cm/s is indicative of a tight monolayer. [10]
Low P _{app} values for control compounds with known high permeability.	Poor solubility of the compound in the assay buffer.	<ol style="list-style-type: none"> 1. Check the solubility of your compound in the assay buffer at the tested concentration. 2. If solubility is an issue, consider adding a solubilizing agent like Bovine Serum Albumin (BSA) to the buffer. [11]
Low percent recovery of the compound at the end of the assay.	<ul style="list-style-type: none"> - Compound binding to the plasticware. - Metabolism by Caco-2 cells. - Accumulation within the cell monolayer. 	<ol style="list-style-type: none"> 1. Use low-binding plates. 2. Analyze cell lysates and wash solutions to quantify compound accumulation and binding. 3. Perform a stability assay of the compound in the presence of Caco-2 cells to assess metabolism. [11]

Guide 2: Investigating P-glycoprotein (P-gp) Efflux

Question	Experimental Approach	Interpretation of Results
Is my Nitidanib derivative a substrate of P-gp?	Perform a bidirectional Caco-2 assay, measuring permeability from the apical (A) to basolateral (B) side and from the basolateral (B) to the apical (A) side.[11]	An efflux ratio (Papp B-A / Papp A-B) greater than 2 suggests that the compound is a substrate for an efflux transporter like P-gp.[6][11]
How can I confirm P-gp involvement?	Repeat the bidirectional assay in the presence of a known P-gp inhibitor, such as verapamil.[6]	If the efflux ratio decreases significantly in the presence of the inhibitor, it confirms the involvement of P-gp.
My compound is a P-gp substrate. What are the implications?	High P-gp efflux will likely lead to low oral bioavailability and reduced penetration into tissues with high P-gp expression (e.g., the brain).	Consider medicinal chemistry strategies to design derivatives that are not P-gp substrates or formulation approaches to bypass P-gp-mediated efflux.

Physicochemical Properties of Nitidanib

Property	Value	Implication for Cell Permeability
Molecular Weight	539.6 g/mol [12]	Within the range for oral bioavailability, but on the higher side.
logP	3.7[13]	Indicates good lipophilicity, which is favorable for passive diffusion.
Aqueous Solubility	pH-dependent; low at neutral pH[1][2]	Poor solubility in the intestinal environment can limit absorption.
Plasma Protein Binding	~98%[1]	High binding can limit the free fraction of the drug available to cross cell membranes.
BCS Classification	Class 2 or 4[1][2]	Low solubility is a primary limiting factor for absorption.

Experimental Protocols

Protocol 1: Caco-2 Cell Permeability Assay

This protocol provides a general workflow for assessing the permeability of Nitidanib derivatives.

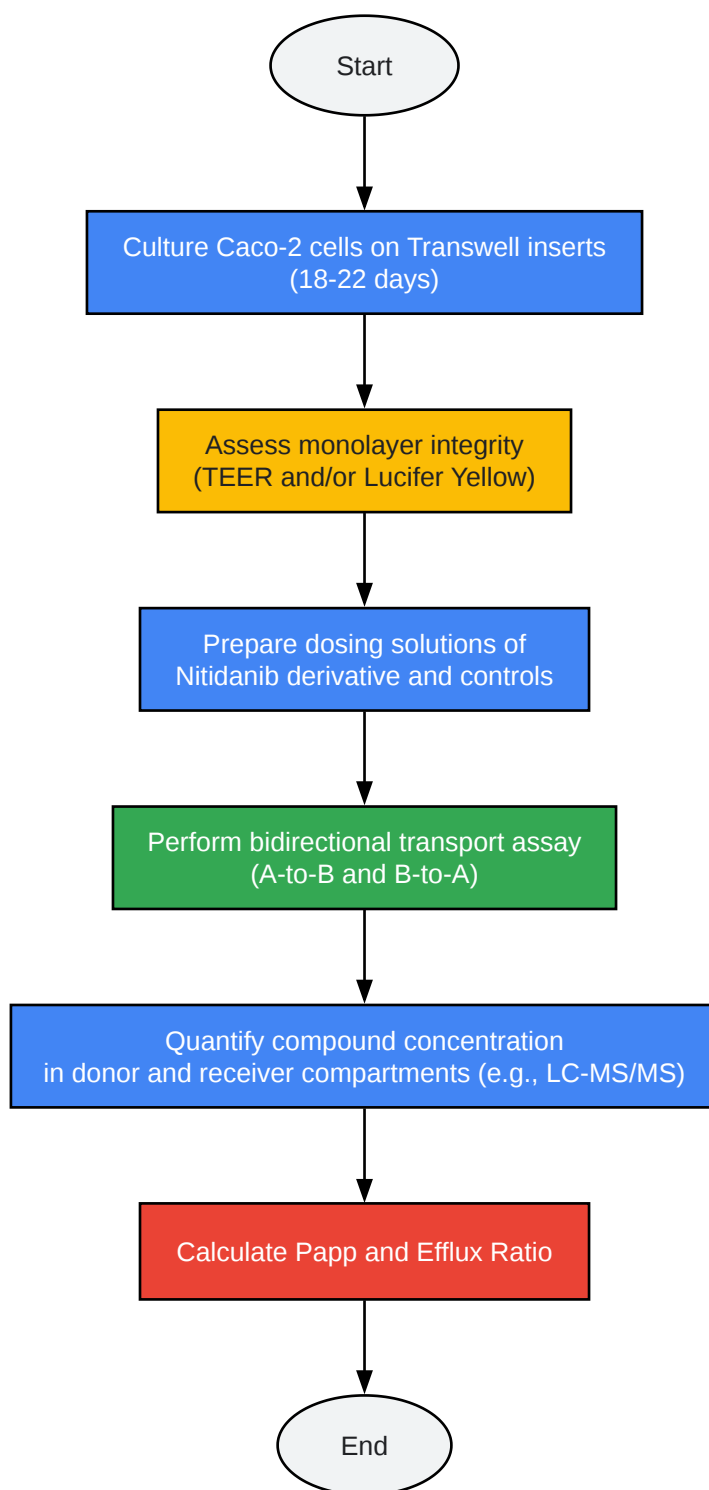

[Click to download full resolution via product page](#)

Caption: Workflow for a Caco-2 cell permeability assay.

Methodology:

- Cell Culture: Seed Caco-2 cells on permeable Transwell® inserts and culture for 18-22 days to allow for differentiation and formation of a confluent monolayer.[11]
- Monolayer Integrity Check:
 - Measure the TEER of each insert using a voltohmmeter. Only use inserts with TEER values above a pre-determined threshold.
 - Alternatively, incubate the monolayers with Lucifer Yellow and measure its transport. A low Papp value for Lucifer Yellow confirms tight junction integrity.[10]
- Transport Experiment:
 - Wash the cell monolayers with pre-warmed Hanks' Balanced Salt Solution (HBSS).
 - For A-to-B permeability, add the dosing solution containing the test compound to the apical chamber and fresh HBSS to the basolateral chamber.
 - For B-to-A permeability, add the dosing solution to the basolateral chamber and fresh HBSS to the apical chamber.
 - Incubate at 37°C with gentle shaking for a defined period (e.g., 2 hours).[11]
- Sample Analysis: At the end of the incubation, collect samples from the donor and receiver chambers and determine the concentration of the compound using a suitable analytical method like LC-MS/MS.
- Data Analysis: Calculate the apparent permeability coefficient (Papp) using the following equation:

$$P_{app} \text{ (cm/s)} = (dQ/dt) / (A * C_0)$$

Where:

- dQ/dt is the rate of drug transport (mol/s)
- A is the surface area of the membrane (cm²)

- C_0 is the initial concentration in the donor chamber (mol/cm^3)

Calculate the efflux ratio as $P_{\text{app}}(\text{B-A}) / P_{\text{app}}(\text{A-B})$.[\[11\]](#)

Protocol 2: Logical Flow for Troubleshooting Permeability Issues

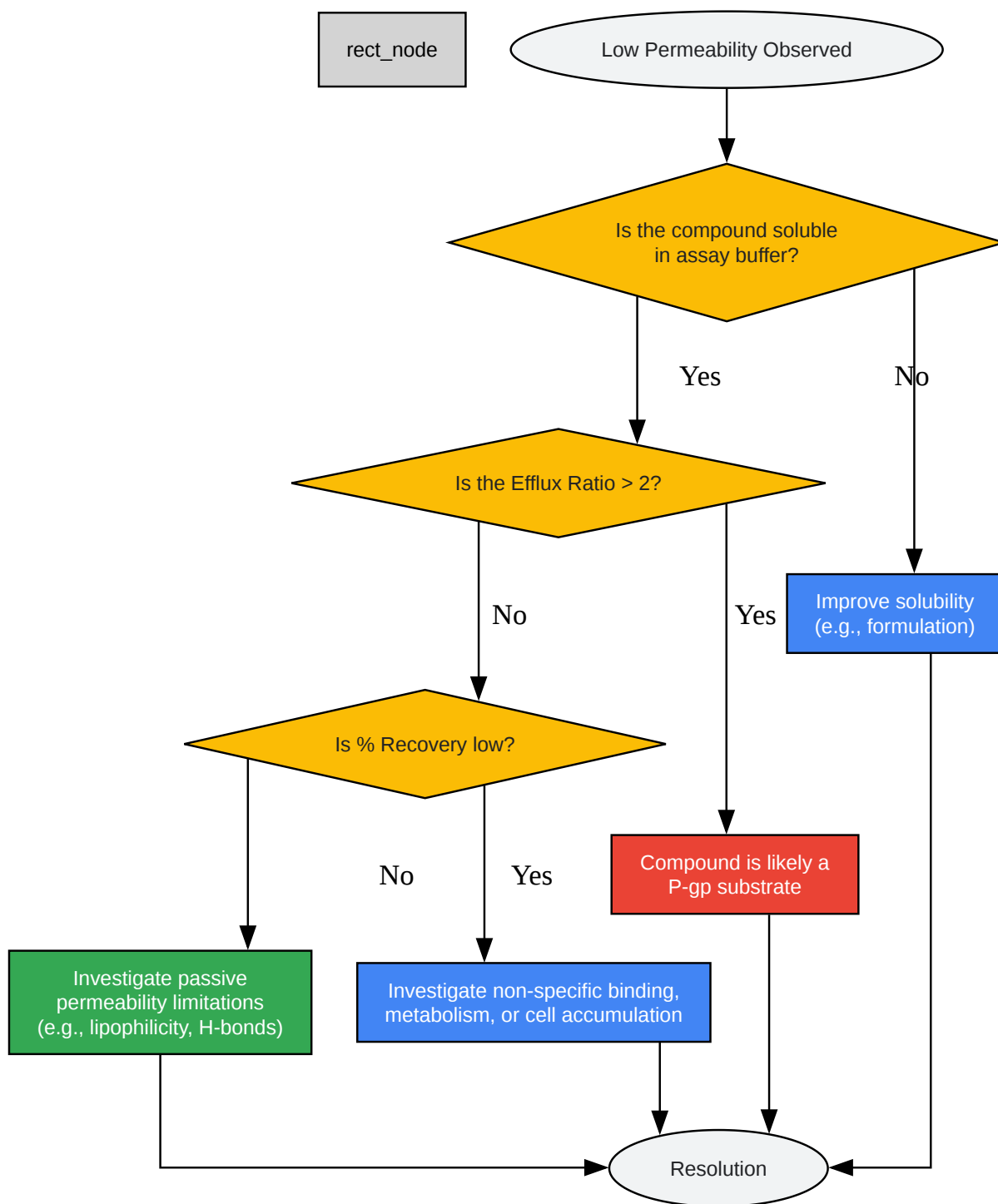

[Click to download full resolution via product page](#)

Caption: Logical workflow for troubleshooting poor permeability.

Need Custom Synthesis?

BenchChem offers custom synthesis for rare earth carbides and specific isotopic labeling.

Email: info@benchchem.com or [Request Quote Online](#).

References

- [1. Clinical Pharmacokinetics and Pharmacodynamics of Nintedanib - PMC \[pmc.ncbi.nlm.nih.gov\]](#)
- [2. accessdata.fda.gov \[accessdata.fda.gov\]](#)
- [3. researchgate.net \[researchgate.net\]](#)
- [4. Improving The Oral Absorption Of Nintedanib By A Self-Microemulsion Drug Delivery System: Preparation And In Vitro/In Vivo Evaluation - PMC \[pmc.ncbi.nlm.nih.gov\]](#)
- [5. researchgate.net \[researchgate.net\]](#)
- [6. Caco-2 permeability assay - Creative Bioarray | Creative Bioarray \[creative-bioarray.com\]](#)
- [7. Mode of action of nintedanib in the treatment of idiopathic pulmonary fibrosis - PMC \[pmc.ncbi.nlm.nih.gov\]](#)
- [8. Novel Mechanisms for the Antifibrotic Action of Nintedanib - PMC \[pmc.ncbi.nlm.nih.gov\]](#)
- [9. static1.1.sqspcdn.com \[static1.1.sqspcdn.com\]](#)
- [10. benchchem.com \[benchchem.com\]](#)
- [11. Caco-2 Permeability | Evotec \[evotec.com\]](#)
- [12. Nintedanib | C31H33N5O4 | CID 135423438 - PubChem \[pubchem.ncbi.nlm.nih.gov\]](#)
- [13. go.drugbank.com \[go.drugbank.com\]](#)
- To cite this document: BenchChem. [Technical Support Center: Enhancing Cell Permeability of Nitidanib Derivatives]. BenchChem, [2026]. [Online PDF]. Available at: [\[https://www.benchchem.com/product/b15560970/docs#technical-support-center-enhancing-cell-permeability-of-nitidanib-derivatives\]](https://www.benchchem.com/product/b15560970/docs#technical-support-center-enhancing-cell-permeability-of-nitidanib-derivatives)

Disclaimer & Data Validity:

The information provided in this document is for Research Use Only (RUO) and is strictly not intended for diagnostic or therapeutic procedures. While BenchChem strives to provide

accurate protocols, we make no warranties, express or implied, regarding the fitness of this product for every specific experimental setup.

Technical Support: The protocols provided are for reference purposes. Unsure if this reagent suits your experiment?

Need Industrial/Bulk Grade? [Request Custom Synthesis Quote](#)

BenchChem

Our mission is to be the trusted global source of essential and advanced chemicals, empowering scientists and researchers to drive progress in science and industry.

Contact

Address: 3281 E Guasti Rd

Ontario, CA 91761, United States

Phone: (601) 213-4426

Email: info@benchchem.com

[Contact our Ph.D. Support Team for a compatibility check](#)