

Nintedanib's Role in Modulating Inflammatory Responses: A Technical Guide

Author: BenchChem Technical Support Team. **Date:** April 2026

Compound of Interest

Compound Name: Nitidanin
Cat. No.: B15560970

[Get Quote](#)

For Researchers, Scientists, and Drug Development Professionals

Executive Summary

Nintedanib, a potent small molecule tyrosine kinase inhibitor (TKI), has emerged as a significant therapeutic agent in the management of fibrotic diseases, most notably idiopathic pulmonary fibrosis (IPF).^{[1][2][3][4]} Its efficacy is largely attributed to its ability to simultaneously target multiple receptor tyrosine kinases involved in fibrogenesis: vascular endothelial growth factor receptor (VEGFR), fibroblast growth factor receptor (FGFR), and platelet-derived growth factor receptor (PDGFR).^{[1][4][5][6][7][8][9]} Beyond its well-documented anti-fibrotic effects, a growing body of evidence highlights nintedanib's profound immunomodulatory and anti-inflammatory properties. This technical guide provides an in-depth exploration of nintedanib's mechanisms in tempering inflammatory responses, supported by quantitative data, detailed experimental protocols, and visual representations of key pathways and workflows.

Core Mechanism of Action in Inflammation

Nintedanib competitively binds to the intracellular ATP-binding pocket of VEGFR, FGFR, and PDGFR, thereby inhibiting the autophosphorylation and activation of these receptors.^{[1][7]} This

blockade disrupts downstream signaling cascades that are crucial for the proliferation, migration, and activation of various inflammatory and pro-fibrotic cells. Additionally, nintedanib has been shown to inhibit non-receptor tyrosine kinases such as Src and Lck, further broadening its immunomodulatory effects.[\[6\]](#)[\[7\]](#)[\[10\]](#)

Modulation of Key Inflammatory Cells

Macrophages

Macrophages play a pivotal role in orchestrating the inflammatory and subsequent fibrotic response. Nintedanib significantly influences macrophage polarization and function. Specifically, it has been demonstrated to impair the polarization of monocytes into M2 (alternatively activated) macrophages, which are known to promote fibrosis.[\[5\]](#)[\[11\]](#) Furthermore, nintedanib can reduce the secretion of pro-inflammatory cytokines from M1 (classically activated) macrophages.[\[12\]](#)[\[13\]](#)

T-Lymphocytes

T-cells are key regulators of the immune response, and their dysregulation can contribute to chronic inflammation and fibrosis. Nintedanib has been shown to dampen T-cell activity by inhibiting their activation and subsequent release of a broad spectrum of cytokines, including IFN- γ , IL-2, IL-4, IL-5, IL-10, IL-12p70, and IL-13.[\[14\]](#) This effect is mediated, at least in part, through the inhibition of Lck phosphorylation, a critical step in T-cell activation.[\[14\]](#)

Quantitative Effects on Inflammatory Mediators

The following tables summarize the quantitative data from various preclinical studies on the effect of nintedanib on key inflammatory cytokines, chemokines, and other mediators.

Table 1: Effect of Nintedanib on Pro-Inflammatory Cytokines

Cytokine	Experimental Model	Nintedanib Concentration/ Dose	Observed Effect	Reference
IL-1 β	Bleomycin-induced lung fibrosis (mice)	30 & 100 mg/kg/day	Significant reduction in lung homogenates	[1]
IL-1 β	Silica-induced lung fibrosis (mice)	30 & 100 mg/kg/day	Significant reduction in lung homogenates	[1]
IL-1 β	LPS-primed human M1 macrophages	200-1000 nM	Inhibition of silica-induced release	[12]
IL-6	LPS-stimulated human M1 macrophages	200-1000 nM	Significant decrease in secretion	[12]
IL-6	Unilateral Ureteral Obstruction (UUO) model (kidney)	Not specified	Reduction in production	[10]
IL-8	LPS-stimulated human M1 macrophages	200-1000 nM	Significant decrease in secretion	[12]
TNF- α	Unilateral Ureteral Obstruction (UUO) model (kidney)	Not specified	Reduction in production	[10]
IL-10	LPS-stimulated human M1 macrophages	200-1000 nM	Significant decrease in secretion	[12]

Table 2: Effect of Nintedanib on Chemokines and Other Inflammatory Markers

Marker	Experimental Model	Nintedanib Concentration/ Dose	Observed Effect	Reference
CXCL1/KC	Silica-induced lung fibrosis (mice)	30 & 100 mg/kg/day	Significant reduction in lung homogenates	[1]
MCP-1	Unilateral Ureteral Obstruction (UUO) model (kidney)	Not specified	Reduction in production	[10]
TIMP-1	Bleomycin-induced lung fibrosis (mice)	Not specified	Reduction in lung tissue levels	[1]
TIMP-1	Silica-induced lung fibrosis (mice)	30 & 100 mg/kg/day	Significant reduction in lung homogenates	[1]
Lymphocytes	Bleomycin-induced lung fibrosis (mice)	30, 60, or 100 mg/kg/day	Significant reduction in BALF	[15]
Neutrophils	Silica-induced lung fibrosis (mice)	30 & 100 mg/kg/day	Significant reduction in BALF	[1][15]

Signaling Pathways Modulated by Nintedanib

The anti-inflammatory effects of nintedanib are a direct consequence of its ability to inhibit key signaling pathways downstream of VEGFR, FGFR, and PDGFR.

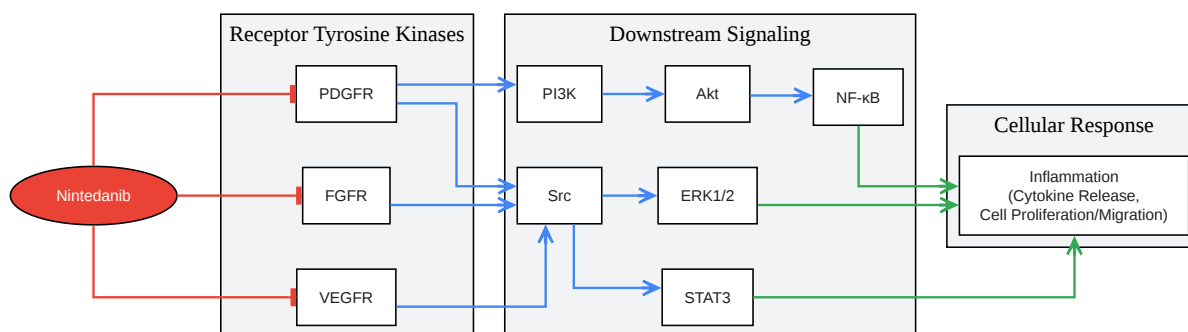

[Click to download full resolution via product page](#)

Caption: Nintedanib inhibits VEGFR, FGFR, and PDGFR, blocking downstream signaling pathways like Src, PI3K/Akt, and ERK, which are crucial for inflammatory responses.

Experimental Protocols

In Vitro Macrophage Polarization Assay

This protocol details the methodology used to assess the impact of nintedanib on human macrophage polarization.[12]

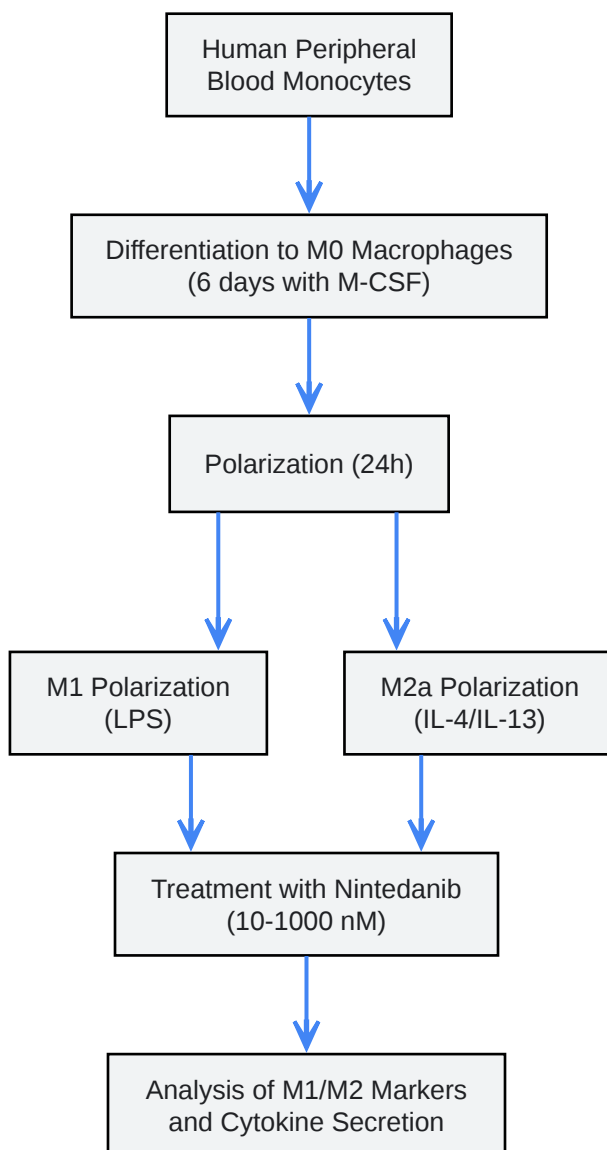

[Click to download full resolution via product page](#)

Caption: Experimental workflow for assessing nintedanib's effect on macrophage polarization.

Methodology:

- Isolation of Monocytes: Human peripheral blood monocytes are isolated from healthy donors.
- Differentiation to M0 Macrophages: Monocytes are cultured for 6 days in the presence of macrophage colony-stimulating factor (M-CSF) to differentiate them into non-polarized M0 macrophages.

- Polarization and Treatment: M0 macrophages are then polarized into M1 macrophages using lipopolysaccharide (LPS) or into M2a macrophages using interleukin-4 (IL-4) and IL-13. Concurrently, cells are treated with varying concentrations of nintedanib (e.g., 10-1000 nM).
- Analysis: After 24 hours of incubation, cell surface markers for M1 (e.g., CD80, CD86) and M2 (e.g., CD206, CD163) are analyzed by flow cytometry. The supernatant is collected to measure the secretion of various cytokines and chemokines using enzyme-linked immunosorbent assay (ELISA) or multiplex assays.

In Vivo Bleomycin-Induced Lung Fibrosis Model

This animal model is widely used to study the anti-inflammatory and anti-fibrotic effects of therapeutic agents.^{[1][15]}

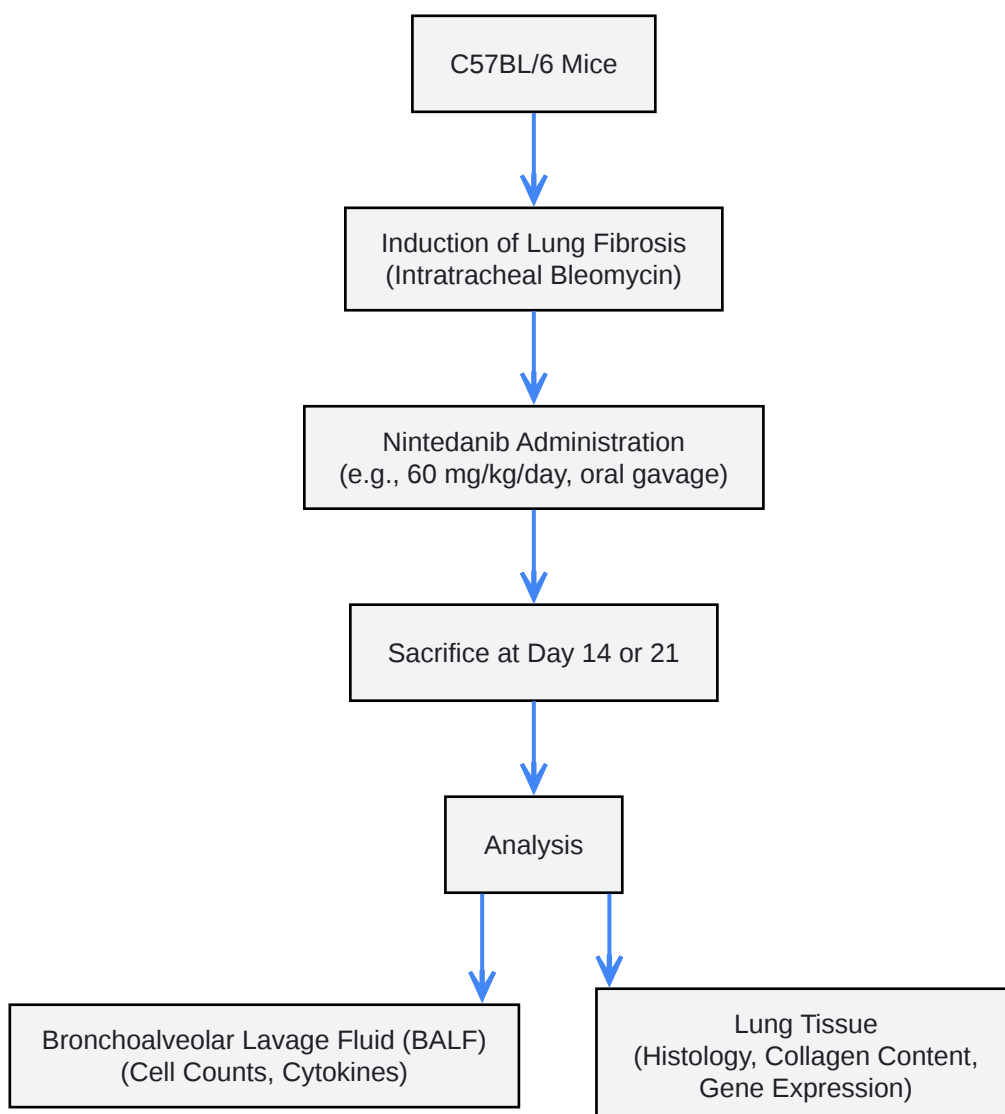

[Click to download full resolution via product page](#)

Caption: Workflow for the bleomycin-induced lung fibrosis model to evaluate nintedanib's efficacy.

Methodology:

- Animal Model: C57BL/6 mice are commonly used.
- Induction of Fibrosis: A single intratracheal instillation of bleomycin sulfate is administered to induce lung injury and subsequent fibrosis.
- Treatment: Nintedanib is administered daily via oral gavage, typically starting on the day of bleomycin administration (prophylactic regimen) or after a few days (therapeutic regimen).
- Endpoint Analysis: At a predetermined time point (e.g., 14 or 21 days post-bleomycin), mice are euthanized.
- Sample Collection and Analysis:
 - Bronchoalveolar Lavage Fluid (BALF): The lungs are lavaged to collect BALF for differential cell counts (macrophages, neutrophils, lymphocytes) and measurement of cytokine levels.
 - Lung Tissue: The lungs are harvested for histological analysis (e.g., H&E and Masson's trichrome staining to assess inflammation and collagen deposition), measurement of total collagen content (e.g., Sircol assay), and analysis of gene and protein expression of inflammatory and fibrotic markers.

Conclusion and Future Directions

Nintedanib exerts significant anti-inflammatory effects that complement its primary anti-fibrotic activity. Its ability to modulate key inflammatory cells like macrophages and T-lymphocytes, and to suppress a wide array of pro-inflammatory mediators, underscores its multifaceted mechanism of action. The quantitative data and experimental models presented in this guide provide a solid foundation for further research into the immunomodulatory properties of nintedanib.

Future research should focus on elucidating the precise molecular interactions of nintedanib with various immune cell subtypes and further exploring its effects on other inflammatory pathways. Additionally, the development of more sophisticated in vitro and in vivo models will be crucial for a deeper understanding of its therapeutic potential in a broader range of inflammatory and fibrotic diseases. The continued investigation of nintedanib's role in modulating inflammatory responses holds promise for optimizing its clinical use and for the development of novel anti-inflammatory and anti-fibrotic therapies.

Need Custom Synthesis?

BenchChem offers custom synthesis for rare earth carbides and specific isotopic labeling.

Email: info@benchchem.com or [Request Quote Online](#).

References

- [1. Mode of action of nintedanib in the treatment of idiopathic pulmonary fibrosis - PMC \[pmc.ncbi.nlm.nih.gov\]](#)
- [2. Nintedanib in the management of idiopathic pulmonary fibrosis: clinical trial evidence and real-world experience - PMC \[pmc.ncbi.nlm.nih.gov\]](#)
- [3. research.manchester.ac.uk \[research.manchester.ac.uk\]](#)
- [4. Idiopathic pulmonary fibrosis - Wikipedia \[en.wikipedia.org\]](#)
- [5. ard.bmj.com \[ard.bmj.com\]](#)
- [6. Nintedanib - StatPearls - NCBI Bookshelf \[ncbi.nlm.nih.gov\]](#)
- [7. publications.ersnet.org \[publications.ersnet.org\]](#)
- [8. Pardon Our Interruption \[pro.boehringer-ingenelheim.com\]](#)
- [9. Nintedanib: evidence for its therapeutic potential in idiopathic pulmonary fibrosis - PMC \[pmc.ncbi.nlm.nih.gov\]](#)
- [10. Application of nintedanib and other potential anti-fibrotic agents in fibrotic diseases - PMC \[pmc.ncbi.nlm.nih.gov\]](#)
- [11. Nintedanib inhibits macrophage activation and ameliorates vascular and fibrotic manifestations in the Fra2 mouse model of systemic sclerosis - PubMed \[pubmed.ncbi.nlm.nih.gov\]](#)
- [12. publications.ersnet.org \[publications.ersnet.org\]](#)

- [13. Alteration of human macrophage phenotypes by the anti-fibrotic drug nintedanib - PubMed \[pubmed.ncbi.nlm.nih.gov\]](#)
- [14. The Effect of Nintedanib on T-Cell Activation, Subsets and Functions - PMC \[pmc.ncbi.nlm.nih.gov\]](#)
- [15. \[PDF\] Antifibrotic and Anti-inflammatory Activity of the Tyrosine Kinase Inhibitor Nintedanib in Experimental Models of Lung Fibrosis | Semantic Scholar \[semanticscholar.org\]](#)
- To cite this document: BenchChem. [Nintedanib's Role in Modulating Inflammatory Responses: A Technical Guide]. BenchChem, [2026]. [Online PDF]. Available at: [<https://www.benchchem.com/product/b15560970/docs#nintedanib-s-role-in-modulating-inflammatory-responses-a-technical-guide>]

Disclaimer & Data Validity:

The information provided in this document is for Research Use Only (RUO) and is strictly not intended for diagnostic or therapeutic procedures. While BenchChem strives to provide accurate protocols, we make no warranties, express or implied, regarding the fitness of this product for every specific experimental setup.

Technical Support: The protocols provided are for reference purposes. Unsure if this reagent suits your experiment?

Need Industrial/Bulk Grade? [Request Custom Synthesis Quote](#)

BenchChem

Our mission is to be the trusted global source of essential and advanced chemicals, empowering scientists and researchers to drive progress in science and industry.

Contact

Address: 3281 E Guasti Rd
Ontario, CA 91761, United States
Phone: (601) 213-4426
Email: info@benchchem.com

Contact our Ph.D. Support Team for a compatibility check