

RYL-552: A Multi-Target Approach to Combat Malaria

Author: BenchChem Technical Support Team. **Date:** April 2026

Compound of Interest

Compound Name: RYL-552
Cat. No.: B15559437

[Get Quote](#)

A Technical Whitepaper on the Target Validation of a Novel Antimalarial Candidate

For Researchers, Scientists, and Drug Development Professionals

This document provides a comprehensive technical overview of the target validation of **RYL-552**, a promising antimalarial compound with a multi-target mechanism of action against *Plasmodium falciparum*, the deadliest species of malaria parasite. By engaging multiple targets within the parasite's mitochondrial respiratory chain, **RYL-552** presents a compelling strategy to combat the growing threat of drug resistance. This guide details the quantitative data supporting its efficacy, the experimental protocols for its validation, and visual representations of its mechanism and validation workflows.

Executive Summary

RYL-552 is a potent, multi-targeting small molecule designed to disrupt the essential mitochondrial respiratory chain of *Plasmodium falciparum*. Its primary mode of action involves the simultaneous inhibition of two key enzymatic complexes: type II NADH dehydrogenase (PfNDH2) and the cytochrome bc1 complex (complex III). Evidence also suggests a potential secondary activity against dihydroorotate dehydrogenase (PfDHODH). This multi-pronged attack on the parasite's energy and nucleotide metabolism pathways makes **RYL-552** and its

analogs, such as the highly potent RYL-581, significant candidates in the pipeline for next-generation antimalarials. In murine models, **RYL-552** has demonstrated the ability to effectively clear parasitemia, underscoring its potential for in vivo efficacy.[1]

Quantitative Data: In Vitro Potency and Selectivity

The following tables summarize the key quantitative data that validate the efficacy and targets of **RYL-552** and its optimized analog, RYL-581.

Table 1: In Vitro Activity against *P. falciparum*

Compound	<i>P. falciparum</i> Strain	EC50 (nM)
RYL-552	3D7	Not explicitly stated, but parent for RYL-581
RYL-581	3D7	0.056[1]

Table 2: Enzymatic Inhibition Data

Compound	Target Enzyme	IC50 (nM)	Notes
RYL-552	PfNDH2	3.73[1]	Non-competitive inhibitor[1]
RYL-581	PfNDH2	Potency improved from RYL-552[1]	

Table 3: Multi-Target Profile of the RYL Series

Compound Series	Primary Targets	Potential Secondary Target
RYL (e.g., RYL-552)	PfNDH2, Cytochrome bc1 (Qo and Qi sites)[1]	PfDHODH[1]

Signaling Pathway and Mechanism of Action

RYL-552 exerts its antimalarial effect by disrupting the electron transport chain in the parasite's mitochondria, a critical pathway for ATP synthesis and pyrimidine biosynthesis.

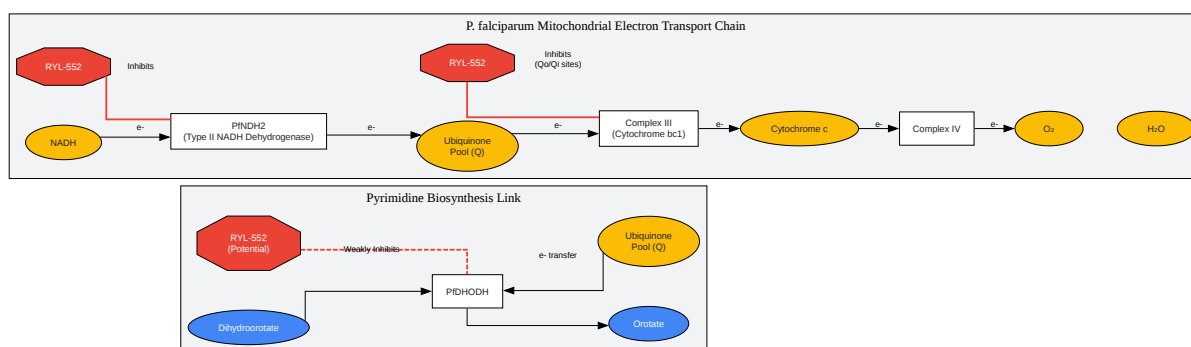

[Click to download full resolution via product page](#)

Caption: Mechanism of **RYL-552** in *P. falciparum* mitochondria.

The diagram above illustrates the multi-target inhibition by **RYL-552**. It blocks the electron flow from NADH to ubiquinone by non-competitively inhibiting PfNDH2.[1] Concurrently, it binds to the Qo and Qi sites of the cytochrome bc1 complex (Complex III), further impeding the electron transport chain.[1] This dual action effectively collapses the mitochondrial membrane potential, halting ATP production. The potential weak inhibition of PfDHODH, an enzyme that also utilizes the ubiquinone pool, suggests an additional, albeit less potent, impact on pyrimidine biosynthesis.[2]

Experimental Protocols for Target Validation

Validating the targets of **RYL-552** involves a combination of genetic and biochemical assays.

Genetic Validation using Transgenic Parasites

Objective: To confirm the role of a specific target in the activity of **RYL-552**.

Methodology:

- **Parasite Lines:** Utilize wild-type (WT) *P. falciparum* (e.g., D10 strain) and a transgenic line where the target of interest is replaced by a drug-insensitive ortholog. For instance, to validate the mitochondrial electron transport chain as the primary target, a yeast dihydroorotate dehydrogenase (yDHODH) transgenic parasite line can be used. This parasite is resistant to inhibitors of the bc1 complex like atovaquone.
- **In Vitro Susceptibility Assay:**
 - Culture both WT and transgenic parasite lines in vitro.
 - Challenge the parasites with serial dilutions of **RYL-552**, a known control for the pathway (e.g., atovaquone), and a negative control (e.g., artemisinin).[2]
 - To further probe the mechanism, assays can be performed in the presence or absence of proguanil, which can sensitize parasites to bc1 inhibitors.[2]
 - After a set incubation period (e.g., 72 hours), measure parasite growth using a SYBR Green I-based fluorescence assay or similar methods.
- **Data Analysis:** Calculate the EC50 values for each compound against both parasite lines. A significant increase in the EC50 value for the transgenic line compared to the WT line indicates that the replaced pathway is the primary target of the compound. For example, if **RYL-552** is significantly less effective against the yDHODH line, it confirms its action on the mitochondrial respiratory chain.[2]

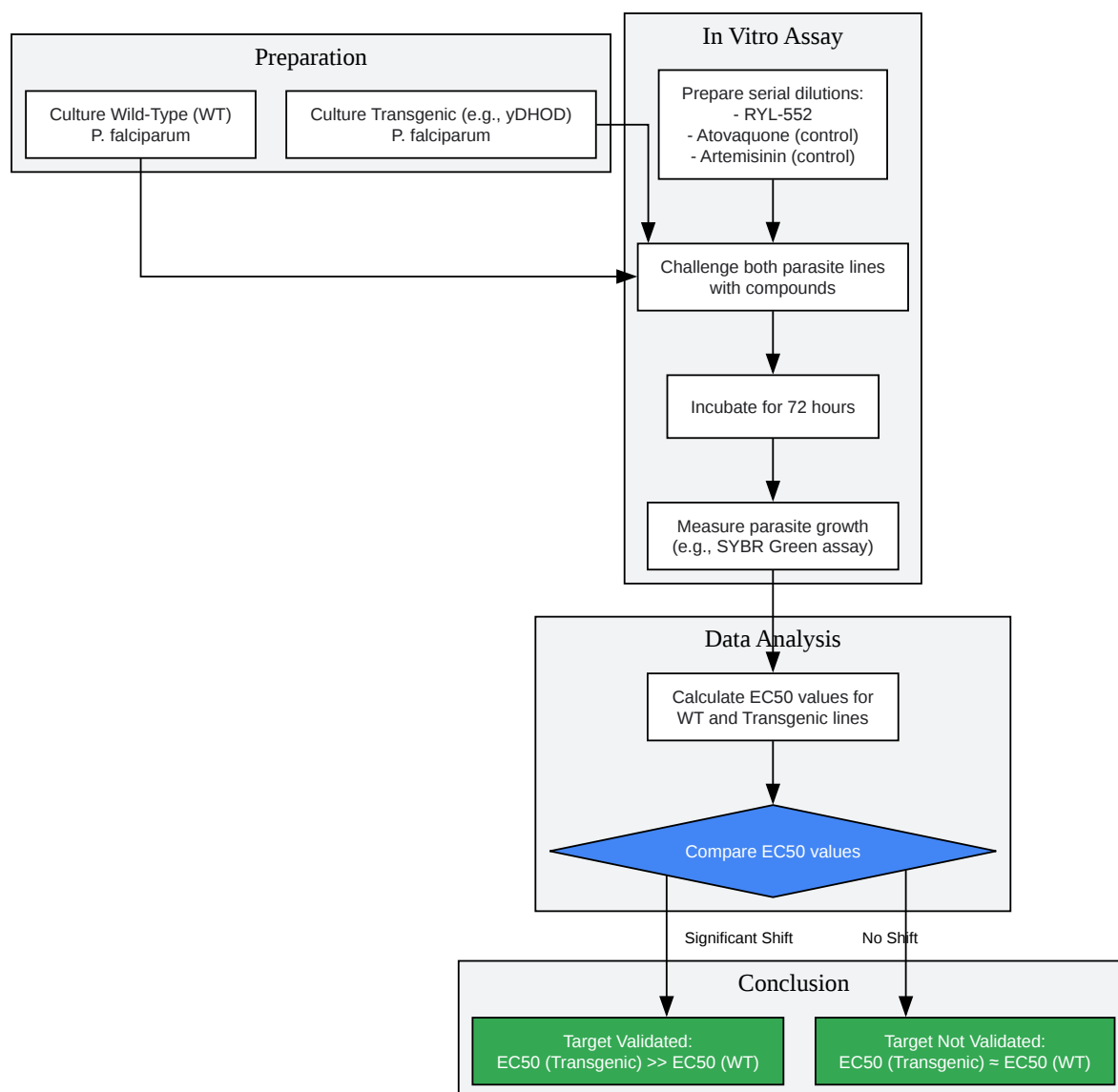

[Click to download full resolution via product page](#)

Need Custom Synthesis?

BenchChem offers custom synthesis for rare earth carbides and specific isotopic labeling.

Email: info@benchchem.com or [Request Quote Online](#).

References

- [1. researchgate.net \[researchgate.net\]](#)
- [2. researchgate.net \[researchgate.net\]](#)
- To cite this document: BenchChem. [RYL-552: A Multi-Target Approach to Combat Malaria]. BenchChem, [2026]. [Online PDF]. Available at: [\[https://www.benchchem.com/product/b15559437/docs#ryl-552-a-multi-target-approach-to-combat-malaria\]](https://www.benchchem.com/product/b15559437/docs#ryl-552-a-multi-target-approach-to-combat-malaria)

Disclaimer & Data Validity:

The information provided in this document is for Research Use Only (RUO) and is strictly not intended for diagnostic or therapeutic procedures. While BenchChem strives to provide accurate protocols, we make no warranties, express or implied, regarding the fitness of this product for every specific experimental setup.

Technical Support: The protocols provided are for reference purposes. Unsure if this reagent suits your experiment?

Need Industrial/Bulk Grade? [Request Custom Synthesis Quote](#)

BenchChem

Our mission is to be the trusted global source of essential and advanced chemicals, empowering scientists and researchers to drive progress in science and industry.

Contact

Address: 3281 E Guasti Rd

Ontario, CA 91761, United States

Phone: (601) 213-4426

Email: info@benchchem.com

Contact our Ph.D. Support Team for a compatibility check