

# Lolamicin: A Technical Whitepaper on the Selective Targeting of Gram-negative Bacteria

**Author:** BenchChem Technical Support Team. **Date:** December 2025

## Compound of Interest

Compound Name: *Lolamicin*

Cat. No.: *B15559531*

[Get Quote](#)

Audience: Researchers, Scientists, and Drug Development Professionals

**Abstract:** The rise of multidrug-resistant (MDR) Gram-negative pathogens presents a formidable challenge to global health. A major limitation of current antibiotic therapies, including broad-spectrum agents, is the collateral damage inflicted upon the host's gut microbiome, leading to dysbiosis and an increased risk of secondary infections such as *Clostridioides difficile*. **Lolamicin** is a novel, investigational antibiotic engineered to overcome this limitation. It exhibits a "doubly selective" mechanism, targeting the Lol lipoprotein transport system unique to Gram-negative bacteria and demonstrating specificity for pathogenic species over commensal ones. This document provides an in-depth technical overview of **lolamicin**, summarizing key preclinical data, detailing experimental methodologies, and visualizing its mechanism and the scientific strategy behind its development.

## Core Mechanism: Inhibition of the Lol Lipoprotein Transport System

**Lolamicin's** bactericidal activity stems from its inhibition of the Lol lipoprotein transport system, a molecular machinery essential and exclusive to Gram-negative bacteria. This system is responsible for trafficking lipoproteins from the inner membrane to the outer membrane, where they are critical for maintaining structural integrity and various cellular functions. The system is comprised of five proteins: LolA, LolB, LolC, LolD, and LolE. The core of the transport machinery in the inner membrane is the LolCDE complex, an ABC transporter that utilizes ATP hydrolysis to extract lipoproteins.

**Lolamicin** acts as a competitive inhibitor of the LolCDE complex. By binding to the transmembrane domains of the LolC and LolE subunits, it disrupts the transport process. This disruption prevents the proper localization of lipoproteins, leading to a dysfunctional outer membrane, observable cellular swelling, and ultimately, cell death.

The selectivity of **lolamicin** for pathogenic bacteria (e.g., *E. coli*, *K. pneumoniae*) over commensal Gram-negative bacteria (e.g., *Bacteroides* spp.) is attributed to sequence divergence in the LolCDE complex. Pathogenic targets exhibit high sequence homology to each other, while the corresponding complex in many commensal species is sufficiently different to preclude effective binding of **lolamicin**. This targeted approach allows **lolamicin** to clear infections while sparing the beneficial gut microbiota.

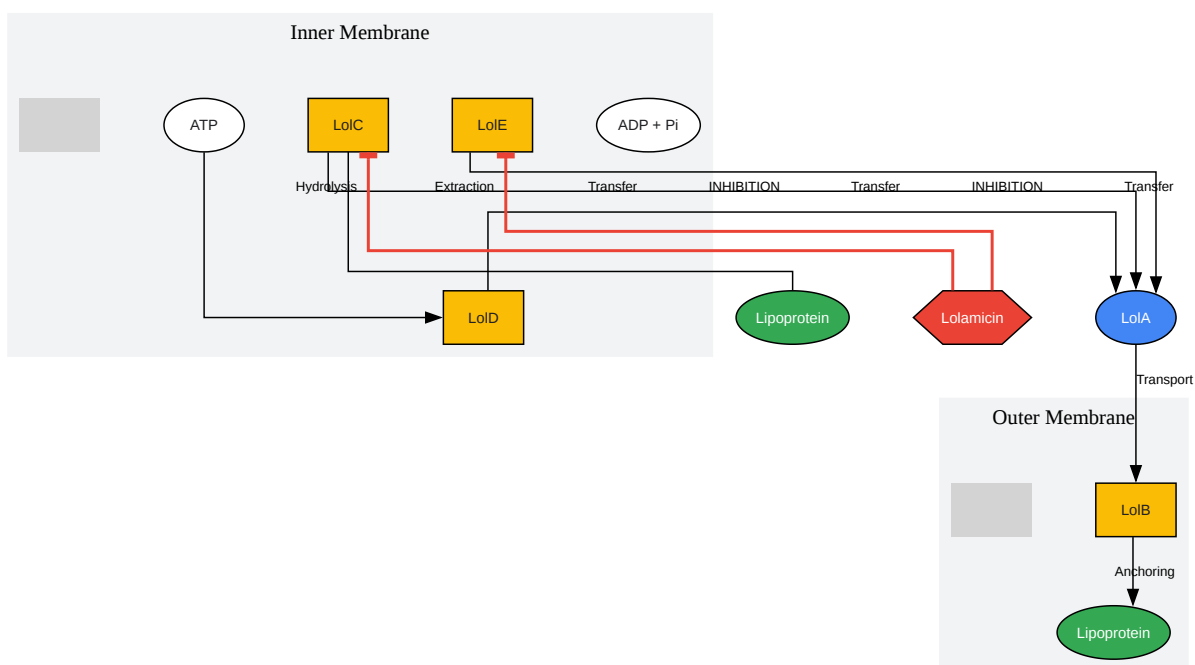

[Click to download full resolution via product page](#)

**Caption:** Mechanism of **Lolamicin** Action on the Lol Lipoprotein Transport System.

## Quantitative Data Summary

**Lolamicin** has demonstrated potent activity against a wide array of MDR Gram-negative clinical isolates while remaining inactive against Gram-positive and anaerobic commensal bacteria. Its efficacy has been confirmed in multiple murine models of infection.

## Table 1: In Vitro Activity (MIC) of Lolamicin

Minimum Inhibitory Concentrations (MICs) were determined following Clinical and Laboratory Standards Institute (CLSI) guidelines. The data shows potent activity against key Gram-negative pathogens and a lack of activity against Gram-positive and commensal species up to its aqueous solubility limit.

Organism Type	Representative Species	Lolamicin MIC (µg/mL)
Gram-negative Pathogens		
Escherichia coli (MDR clinical isolates)	MIC <sub>50</sub> : 1-2, MIC <sub>90</sub> : 4	
Klebsiella pneumoniae (MDR clinical isolates)	MIC <sub>50</sub> : 2, MIC <sub>90</sub> : 4	
Enterobacter cloacae (MDR clinical isolates)	MIC <sub>50</sub> : 2, MIC <sub>90</sub> : 4	
E. coli (Colistin-Resistant AR-0349)	1	
Gram-negative Commensals		
Bacteroides fragilis	>128	
Bacteroides thetaiotaomicron	>128	
Gram-positive Pathogens		
Staphylococcus aureus	>128	
Streptococcus pneumoniae	>128	
Enterococcus faecalis	>128	

MDR: Multidrug-Resistant. MIC<sub>50</sub>/MIC<sub>90</sub>: Concentration inhibiting 50%/90% of isolates.

## Table 2: In Vivo Efficacy of Lolamicin in Murine Infection Models

**Lolamicin** was well-tolerated and demonstrated significant efficacy in reducing bacterial burden and improving survival in acute pneumonia and septicemia models initiated with MDR

Gram-negative pathogens.

Infection Model	Pathogen (Resistance)	Dosing (Route)	Outcome
Septicemia	E. coli AR-0349 (Colistin-R)	100 mg/kg (IP), twice daily for 3 days	100% survival vs. <20% in vehicle group
Pneumonia	E. coli AR-0349 (Colistin-R)	100 mg/kg (IP), twice daily for 3 days	~2-log reduction in lung CFU vs. vehicle
Pneumonia	K. pneumoniae AR-0040 (Colistin-R)	100 mg/kg (IP), twice daily for 3 days	~3-log reduction in lung CFU vs. vehicle
Septicemia	K. pneumoniae BAA-1705 (Carbapenem-R)	100 mg/kg (IP), twice daily for 3 days	100% survival vs. 0% in vehicle group
Septicemia	E. coli AR-0349 (Colistin-R)	200 mg/kg (Oral), twice daily for 3 days	70% survival vs. <20% in vehicle group

IP: Intraperitoneal. CFU: Colony-Forming Units.

### Table 3: Lolamicin Spontaneous Resistance Frequency

The frequency of spontaneous resistance to **lolamicin** was found to be low, particularly when compared to progenitor compounds.

Bacterial Strain	Lolamicin Concentration	Frequency of Resistance
E. coli ΔtolC (efflux deficient)	8x MIC	$2.2 \times 10^{-8}$
E. coli BW25113 (wild-type)	8x MIC	$3.4 \times 10^{-7}$
K. pneumoniae ATCC 27736	8x MIC	$1.2 \times 10^{-8}$

## Experimental Protocols

Detailed methodologies are crucial for the evaluation and replication of findings. The following protocols are summarized based on the methodologies reported in the primary literature.

## Broth Microdilution MIC Assay

This protocol is used to determine the minimum inhibitory concentration (MIC) of **lolamicin** against bacterial isolates.

- Preparation: **Lolamicin** is serially diluted (2-fold) in appropriate broth media (e.g., Mueller-Hinton Broth for aerobic pathogens, Todd-Hewitt or Brain Heart Infusion for anaerobes) in a 96-well microtiter plate.
- Inoculum Preparation: Bacterial isolates are grown to a logarithmic phase and diluted to a final concentration of  $5 \times 10^5$  CFU/mL in the wells of the microtiter plate.
- Incubation: Plates are incubated at 37°C for 18-24 hours. For anaerobic commensals, incubation occurs under anaerobic conditions.
- Endpoint Determination: The MIC is defined as the lowest concentration of **lolamicin** that completely inhibits visible bacterial growth, as determined by visual inspection or spectrophotometric reading (OD<sub>600</sub>). Controls for sterility (media only) and growth (media with inoculum, no drug) are included.

## Murine Infection Models (Pneumonia & Septicemia)

These protocols assess the in vivo efficacy of **lolamicin**. All animal procedures are conducted in accordance with institutional and national animal welfare guidelines.

- Animal Model: CD-1 mice are typically used.
- Infection:
  - Pneumonia Model: Mice are anesthetized and intranasally inoculated with a high-titer bacterial suspension (e.g.,  $2.7 \times 10^8$  CFU/mouse for E. coli AR-0349).
  - Septicemia Model: Mice are infected via intraperitoneal injection of the bacterial suspension (e.g.,  $4.2 \times 10^8$  CFU/mouse for E. coli AR-0349).
- Treatment: Treatment is initiated post-infection (e.g., 1-2 hours). **Lolamicin** is administered, typically twice daily for 3 days, via intraperitoneal (100 mg/kg) or oral (200 mg/kg) routes. A vehicle control group is run in parallel.

- Endpoint Evaluation:
  - Pneumonia: At 24 hours after the final dose, mice are euthanized, lungs are harvested, homogenized, and serially diluted for CFU plating to determine bacterial burden.
  - Septicemia: Mice are monitored for survival over a period of 7-10 days.

## Gut Microbiome Analysis via 16S rRNA Sequencing

This protocol evaluates the impact of antibiotic treatment on the gut microbial community.

- Sample Collection: Fecal samples are collected from mice before, during, and after a course of antibiotic treatment (e.g., **lolamicin**, amoxicillin, clindamycin, or vehicle). Samples are immediately stored at -80°C.
- DNA Extraction: Total genomic DNA is extracted from fecal samples using a commercially available kit designed for stool samples.
- 16S rRNA Gene Amplification: The V4 hypervariable region of the 16S rRNA gene is amplified from the extracted DNA using universal primers (e.g., 515F/806R).
- Sequencing: The resulting amplicons are sequenced on a high-throughput platform (e.g., Illumina MiSeq).
- Bioinformatic Analysis: Raw sequence data is processed using a standard pipeline (e.g., QIIME 2). This involves quality filtering, denoising (e.g., DADA2), taxonomic assignment against a reference database (e.g., Greengenes, SILVA), and calculation of diversity metrics (alpha-diversity: richness/evenness; beta-diversity: community composition differences).

## Visualizations: Workflows and Logic

### The "Doubly Selective" Strategy

The development of **lolamicin** was guided by a "doubly selective" strategy designed to target pathogenic Gram-negative bacteria while sparing both Gram-positive organisms and Gram-negative commensals. This logic is a potential blueprint for future antibiotic development.

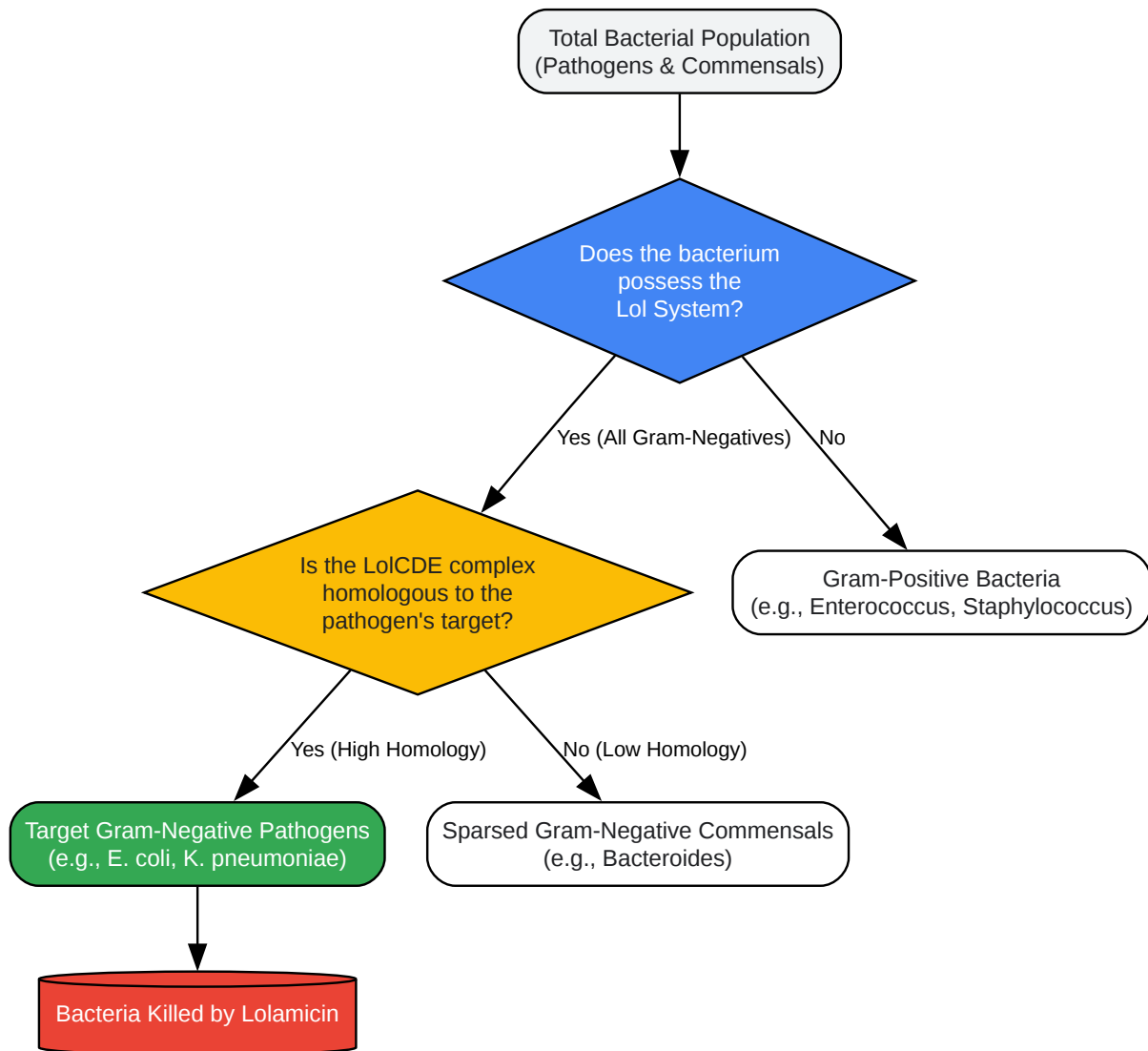

[Click to download full resolution via product page](#)

**Caption:** The logical framework for **lolamicin's** "doubly selective" targeting.

## Preclinical Evaluation Workflow

The path from concept to a viable preclinical candidate involved a structured workflow integrating microbiology, in vivo pharmacology, and microbiome science.



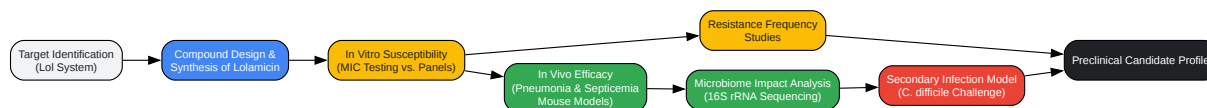

[Click to download full resolution via product page](#)

**Caption:** High-level experimental workflow for the preclinical evaluation of **lolamicin**.

## Conclusion

**Lolamicin** represents a significant advancement in the pursuit of targeted antibacterial therapies. Its novel mechanism of action, focused on the Gram-negative-specific Lol system, combined with a molecular structure that exploits sequence homology divergence between pathogens and commensals, provides a powerful strategy to combat MDR infections while preserving the host microbiome. The preclinical data summarized herein demonstrates potent efficacy and a favorable safety profile in terms of microbiome impact. While further development and clinical trials are necessary, **lolamicin** serves as a proof-of-concept for a new generation of "smart" antibiotics that could fundamentally change the approach to treating bacterial infections.

- To cite this document: BenchChem. [Lolamicin: A Technical Whitepaper on the Selective Targeting of Gram-negative Bacteria]. BenchChem, [2025]. [Online PDF]. Available at: [<https://www.benchchem.com/product/b15559531#lolamicin-selective-targeting-of-gram-negative-bacteria>]

---

### Disclaimer & Data Validity:

The information provided in this document is for Research Use Only (RUO) and is strictly not intended for diagnostic or therapeutic procedures. While BenchChem strives to provide accurate protocols, we make no warranties, express or implied, regarding the fitness of this product for every specific experimental setup.

**Technical Support:** The protocols provided are for reference purposes. Unsure if this reagent suits your experiment? [[Contact our Ph.D. Support Team for a compatibility check](#)]

**Need Industrial/Bulk Grade?** [Request Custom Synthesis Quote](#)

## BenchChem

Our mission is to be the trusted global source of essential and advanced chemicals, empowering scientists and researchers to drive progress in science and industry.

### Contact

Address: 3281 E Guasti Rd  
Ontario, CA 91761, United States  
Phone: (601) 213-4426  
Email: [info@benchchem.com](mailto:info@benchchem.com)