

Technical Support Center: P163-0892 High-Throughput Screening

Author: BenchChem Technical Support Team. **Date:** April 2026

Compound of Interest

Compound Name: P163-0892

Cat. No.: B15558733

[Get Quote](#)

This technical support center provides best practices, troubleshooting guides, and frequently asked questions (FAQs) for utilizing **P163-0892** in high-throughput screening (HTS) assays. The information is tailored for researchers, scientists, and drug development professionals working on antifungal discovery, with a focus on targeting *Cryptococcus* species.

Frequently Asked Questions (FAQs)

Q1: What is **P163-0892** and what is its primary application in HTS?

A1: **P163-0892** is a novel compound with potent and selective antifungal activity against *Cryptococcus* species, the causative agents of cryptococcosis, a life-threatening fungal infection, particularly in immunocompromised individuals.[1] In high-throughput screening (HTS), **P163-0892** is primarily used as a positive control compound in assays designed to identify new anti-cryptococcal agents. Its strong in vitro activity, with Minimum Inhibitory Concentration (MIC) values typically below 1 µg/mL, makes it an excellent benchmark for evaluating the potency of newly discovered compounds.[1]

Q2: What is the mechanism of action of **P163-0892**?

A2: The precise molecular target of **P163-0892** is still under investigation. However, its potent fungicidal activity suggests that it may interfere with essential cellular processes in *Cryptococcus*. Two key pathways that are often targeted by antifungal drugs and are crucial for *Cryptococcus* viability are the ergosterol biosynthesis pathway and the cell wall integrity (CWI) pathway. The ergosterol biosynthesis pathway is responsible for producing ergosterol, a vital component of the fungal cell membrane.[2][3] The CWI pathway is a signaling cascade that regulates the construction and maintenance of the fungal cell wall, which is essential for protecting the cell from environmental stress.[4][5][6][7] Further research is needed to determine if **P163-0892** acts on one of these pathways or has a novel mechanism of action.

Q3: Is **P163-0892** cytotoxic to mammalian cells?

A3: Preliminary in vitro studies have shown that **P163-0892** is not cytotoxic to mammalian cells.[1] However, it is crucial to perform your own cytotoxicity testing on the specific mammalian cell lines used in your experimental workflow to confirm this and to establish a therapeutic window. Standard cell lines for general cytotoxicity assessment include HepG2 (liver carcinoma) and HEK293 (embryonic kidney).

Q4: What are the solubility and stability characteristics of **P163-0892**?

A4: **P163-0892** is a thieno[2,3-b]pyridine derivative. While specific aqueous solubility data for **P163-0892** is not readily available, thieno[2,3-b]pyridine compounds are known to have challenges with aqueous solubility.[8] For HTS applications, **P163-0892** is typically dissolved in dimethyl sulfoxide (DMSO). It is important to prepare fresh dilutions of **P163-0892** in your assay medium from a concentrated DMSO stock for each experiment to minimize potential precipitation. The stability of thieno[2,3-b]pyridine derivatives in solution can be variable, and it is recommended to store DMSO stock solutions at -20°C or -80°C and to limit the number of freeze-thaw cycles.

Experimental Protocols

High-Throughput Screening for Anti-Cryptococcal Activity using the AlamarBlue Assay

This protocol describes a common and robust method for assessing the viability of *Cryptococcus neoformans* in a high-throughput format. The AlamarBlue (resazurin) assay

measures the metabolic activity of cells.

Materials:

- Cryptococcus neoformans strain (e.g., H99)
- Yeast Peptone Dextrose (YPD) broth
- RPMI-1640 medium, buffered with MOPS
- **P163-0892** (positive control)
- Amphotericin B (another common positive control)
- DMSO (vehicle control)
- AlamarBlue reagent
- Sterile, black, clear-bottom 384-well microplates
- Multichannel pipette or automated liquid handler
- Plate reader capable of measuring fluorescence (Ex/Em: ~560/590 nm)

Methodology:

- Inoculum Preparation:
 - Culture *C. neoformans* in YPD broth overnight at 30°C with shaking.
 - Wash the cells with sterile PBS and resuspend in RPMI-1640 medium.
 - Adjust the cell density to 2×10^5 cells/mL in RPMI-1640.
- Compound Plating:
 - Prepare a serial dilution of **P163-0892** and test compounds in DMSO.

- Using an acoustic dispenser or pin tool, transfer a small volume (e.g., 50 nL) of each compound dilution to the wells of the 384-well plate.
- Include wells with DMSO only as a negative (vehicle) control and wells with a known antifungal like Amphotericin B as an additional positive control.
- Cell Seeding:
 - Add 50 μ L of the *C. neoformans* cell suspension to each well of the compound-plated 384-well plate, resulting in a final cell density of 1×10^5 cells/mL.
- Incubation:
 - Incubate the plates at 35°C for 48 hours.
- AlamarBlue Addition and Reading:
 - Add 5 μ L of AlamarBlue reagent to each well.
 - Incubate the plates for an additional 4-6 hours at 35°C, protected from light.
 - Measure the fluorescence at an excitation wavelength of 560 nm and an emission wavelength of 590 nm.

Data Analysis:

- Calculate the percentage of growth inhibition for each compound concentration relative to the DMSO control.
- Determine the IC₅₀ value for **P163-0892** and the test compounds by fitting the dose-response data to a four-parameter logistic curve.

Troubleshooting Guide

Issue	Potential Cause	Recommended Solution
High variability between replicate wells	Inconsistent cell seeding, compound precipitation, or edge effects in the microplate.	Ensure thorough mixing of the cell suspension before and during seeding. Visually inspect compound stock solutions for precipitation. Consider not using the outer wells of the plate if edge effects are significant.
Low Z'-factor (<0.5)	Small dynamic range between positive and negative controls, or high variability.	Optimize the concentrations of the positive control (P163-0892) and the cell seeding density. Ensure the incubation time is sufficient for robust fungal growth.
"Trailing" growth with some compounds	Fungistatic rather than fungicidal effect, where some residual growth persists over a wide range of concentrations.	This is a known phenomenon in antifungal susceptibility testing. Report the MIC as the lowest concentration that produces a significant (e.g., $\geq 50\%$) reduction in signal compared to the growth control.
Compound insolubility	Poor aqueous solubility of the test compound.	Check the DMSO stock for precipitation. Consider reducing the final assay concentration or using a different solvent for the stock solution if compatible with the assay.

False positives	Compound interferes with the AlamarBlue assay (e.g., autofluorescence or direct reduction of resazurin).	Perform a counter-screen in the absence of cells to identify compounds that directly interact with the assay reagents.
-----------------	--	--

Quantitative Data Summary

Table 1: Antifungal Activity of **P163-0892**

Parameter	Value	Reference
MIC against <i>Cryptococcus</i> spp.	< 1 µg/mL	[1]

Table 2: Recommended HTS Assay Parameters

Parameter	Recommended Value
Cell Line	<i>Cryptococcus neoformans</i> H99
Seeding Density (384-well)	5,000 cells/well
Incubation Time	48 hours
P163-0892 Concentration Range	0.01 - 10 µM
DMSO Final Concentration	≤ 0.5%
Z'-factor Target	≥ 0.5

Signaling Pathway and Workflow Diagrams

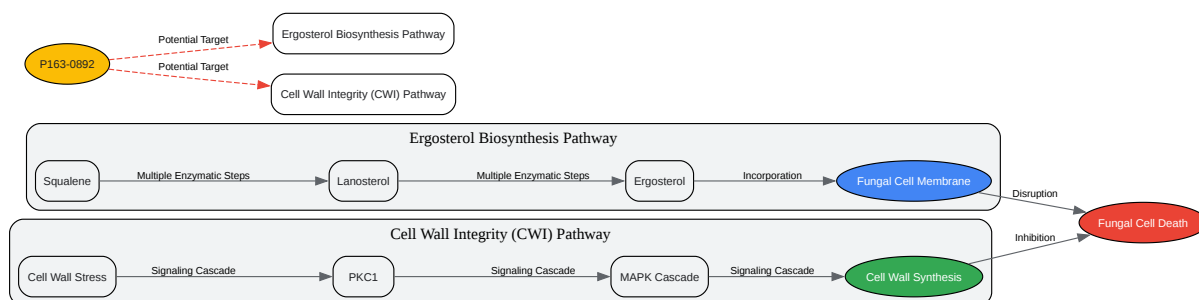

[Click to download full resolution via product page](#)

Caption: Potential mechanisms of action of **P163-0892** on key fungal pathways.

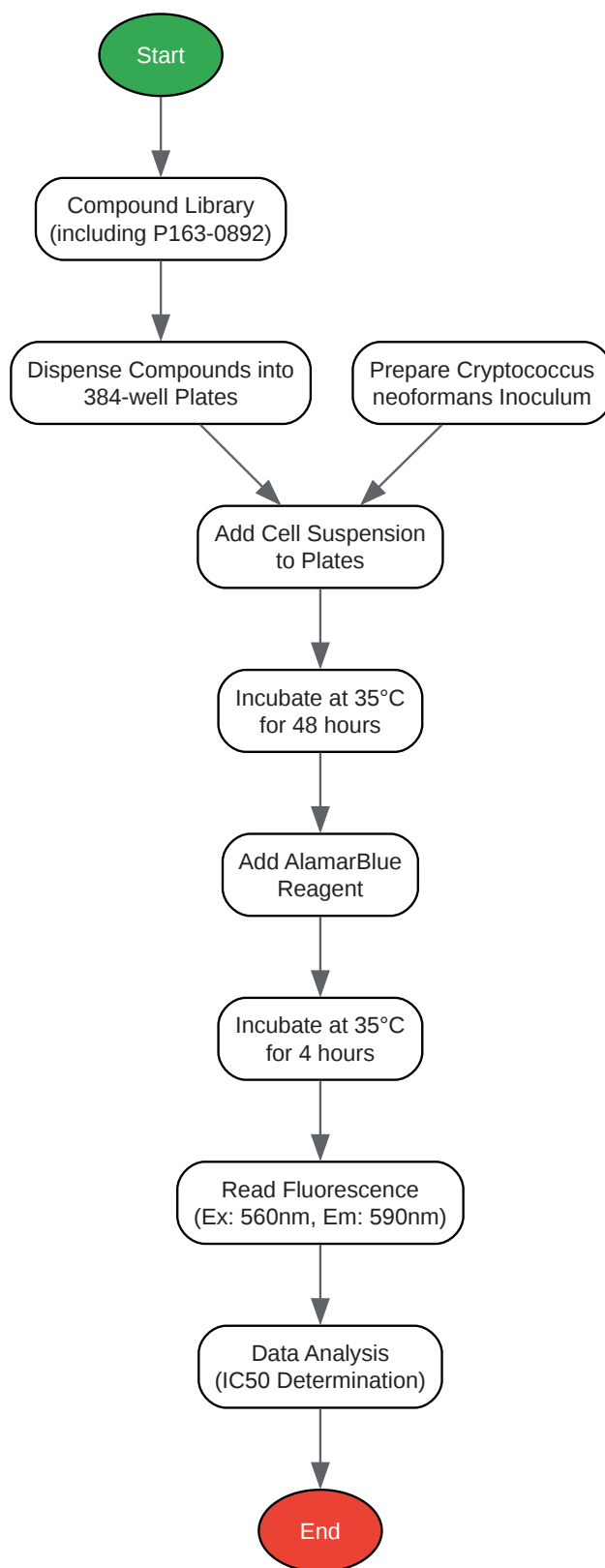

[Click to download full resolution via product page](#)

Caption: High-throughput screening workflow for antifungal compound discovery.

Need Custom Synthesis?

BenchChem offers custom synthesis for rare earth carbides and specific isotopic labeling.

Email: info@benchchem.com or [Request Quote Online](#).

References

- 1. P163-0892 - Drug Targets, Indications, Patents - Synapse [synapse.patsnap.com]
- 2. Ergosterol Is Critical for Sporogenesis in *Cryptococcus neoformans* - PMC [pubmed.ncbi.nlm.nih.gov]
- 3. Ergosterol distribution controls surface structure formation and fungal pathogenicity - PubMed [pubmed.ncbi.nlm.nih.gov]
- 4. Cell wall integrity is dependent on the PKC1 signal transduction pathway in *Cryptococcus neoformans* - PubMed [pubmed.ncbi.nlm.nih.gov]
- 5. JoF | Free Full-Text | Cell Wall Integrity Pathway Involved in Morphogenesis, Virulence and Antifungal Susceptibility in *Cryptococcus neoformans* [mdpi.com]
- 6. Scholars@Duke publication: Cell wall integrity is dependent on the PKC1 signal transduction pathway in *Cryptococcus neoformans*. [scholars.duke.edu]
- 7. Cell Wall Integrity Pathway Involved in Morphogenesis, Virulence and Antifungal Susceptibility in *Cryptococcus neoformans* - PubMed [pubmed.ncbi.nlm.nih.gov]
- 8. Investigation into Improving the Aqueous Solubility of the Thieno[2,3-b]pyridine Anti-Proliferative Agents - PMC [pubmed.ncbi.nlm.nih.gov]
- To cite this document: BenchChem. [Technical Support Center: P163-0892 High-Throughput Screening]. BenchChem, [2026]. [Online PDF]. Available at: [<https://www.benchchem.com/product/b15558733/docs#technical-support-center-p163-0892-high-throughput-screening>]

Disclaimer & Data Validity:

The information provided in this document is for Research Use Only (RUO) and is strictly not intended for diagnostic or therapeutic procedures. While BenchChem strives to provide accurate protocols, we make no warranties, express or implied, regarding the fitness of this product for every specific experimental setup.

Technical Support: The protocols provided are for reference purposes. Unsure if this reagent suits your experiment?

Need Industrial/Bulk Grade? [Request Custom Synthesis Quote](#)

BenchChem

Our mission is to be the trusted global source of essential and advanced chemicals, empowering scientists and researchers to drive progress in science and industry.

Contact

Address: 3281 E Guasti Rd
Ontario, CA 91761, United States
Phone: (601) 213-4426
Email: info@benchchem.com

[Contact our Ph.D. Support Team for a compatibility check](#)