

Deuterated Chlorphenesin as a Research Tool: An In-depth Technical Guide

Author: BenchChem Technical Support Team. **Date:** April 2026

Compound of Interest

Compound Name: Chlorphenesin-D5

Cat. No.: B15558525

[Get Quote](#)

For Researchers, Scientists, and Drug Development Professionals

Executive Summary

Deuterated compounds are increasingly utilized in drug discovery to enhance pharmacokinetic profiles and therapeutic efficacy.^{[1][2]} This guide explores the potential of deuterated chlorphenesin as a research tool. Chlorphenesin is a centrally-acting muscle relaxant, preservative, and immunomodulatory agent.^{[3][4][5]} By strategically replacing hydrogen atoms with deuterium, researchers can investigate and potentially improve its metabolic stability, reduce off-target effects, and prolong its therapeutic action. This document provides a comprehensive overview of the rationale for deuterating chlorphenesin, detailed experimental protocols for its synthesis and evaluation, and visual representations of its known signaling pathways to guide future research.

Introduction to Deuteration in Drug Discovery

Deuterium, a stable, non-radioactive isotope of hydrogen, possesses an additional neutron, resulting in a stronger carbon-deuterium (C-D) bond compared to the carbon-hydrogen (C-H) bond.^{[6][7]} This "kinetic isotope effect" can significantly slow down metabolic processes that involve the cleavage of a C-H bond, which is often a rate-limiting step in drug metabolism.^{[6][8]}

Key Advantages of Deuteration:

- **Improved Metabolic Stability:** Slower metabolism leads to a longer drug half-life and increased exposure.[\[6\]](#)[\[9\]](#)
- **Enhanced Pharmacokinetics:** A longer half-life can result in reduced dosing frequency and improved patient compliance.[\[9\]](#)[\[10\]](#)
- **Reduced Toxic Metabolite Formation:** By slowing metabolism at specific sites, the formation of potentially toxic byproducts can be minimized.[\[6\]](#)
- **Increased Efficacy:** Prolonged exposure to the active drug can lead to enhanced therapeutic effects.[\[6\]](#)
- **Metabolic Shunting:** Deuteration can redirect metabolism away from pathways that lead to inactive or undesirable metabolites.[\[8\]](#)[\[11\]](#)

Deutetrabenazine, the first FDA-approved deuterated drug, exemplifies the clinical success of this strategy, demonstrating a more favorable pharmacokinetic profile compared to its non-deuterated counterpart.[\[1\]](#)[\[9\]](#)

Chlorphenesin: A Multifunctional Molecule

Chlorphenesin, chemically known as 3-(4-chlorophenoxy)-1,2-propanediol, has a history of use as a centrally-acting muscle relaxant, particularly in its carbamate form.[\[3\]](#)[\[12\]](#)[\[13\]](#) It is also widely used as a preservative in cosmetic products due to its antimicrobial properties against various bacteria and fungi.[\[4\]](#)[\[14\]](#)[\[15\]](#) Furthermore, emerging research has highlighted its immunomodulatory activities.[\[4\]](#)[\[16\]](#)[\[17\]](#)

Known Biological Activities of Chlorphenesin:

- **Muscle Relaxation:** Acts on the central nervous system to block nerve impulses and reduce muscle spasms.[\[5\]](#)[\[18\]](#) The exact mechanism is not fully elucidated but is thought to involve the inhibition of spinal reflexes.[\[3\]](#)
- **Antimicrobial Activity:** Effective against a range of gram-positive and gram-negative bacteria, as well as fungi and yeast.[\[14\]](#)[\[19\]](#)

- Immunomodulation: Has been shown to suppress T-lymphocyte activation and proliferation in vitro.[16][20] It has also been observed to inhibit IgE-mediated histamine release.[17]

Rationale for Deuterating Chlorphenesin

The metabolism of chlorphenesin involves several pathways, including oxidation and conjugation.[4][18] The primary urinary metabolites identified are 3-p-chlorophenoxyacetic acid and p-chlorophenoxyacetic acid, along with unchanged chlorphenesin.[4] These metabolic transformations represent opportunities for deuterium substitution to enhance the molecule's properties.

Potential Benefits of a Deuterated Chlorphenesin Analog:

- Prolonged Muscle Relaxant Effect: By slowing the rate of metabolism, a deuterated version could maintain therapeutic concentrations for a longer duration, potentially reducing the frequency of administration for treating musculoskeletal conditions.
- Enhanced Antimicrobial Persistence: In cosmetic formulations, a more stable deuterated chlorphenesin could provide longer-lasting preservative action.
- Sustained Immunomodulatory Activity: For research into its immunomodulatory effects, a deuterated analog would be a valuable tool to study the prolonged impact on signaling pathways like the PI3K/Akt pathway.[20]
- Reduced Potential for Metabolite-Mediated Effects: Altering the metabolic profile could reduce the formation of certain metabolites, allowing for a clearer investigation of the parent compound's activity.

Proposed Synthesis and Characterization

While specific synthesis protocols for deuterated chlorphenesin are not readily available in the public domain, a general approach can be extrapolated from known chlorphenesin synthesis methods and standard deuteration techniques.

Synthesis of Deuterated Chlorphenesin

A common method for synthesizing chlorphenesin involves the reaction of p-chlorophenol with glycidol.[4][21][22] To introduce deuterium, deuterated starting materials would be required. For

example, deuterated glycidol could be used to introduce deuterium onto the propanediol backbone.

Table 1: Proposed Synthetic Starting Materials

Starting Material	Deuterated Analog	Purpose
p-Chlorophenol	p-Chlorophenol	No deuteration on the aromatic ring
Glycidol	Glycidol-d5	Introduce deuterium on the propanediol moiety

Experimental Protocol: Synthesis of **Chlorphenesin-d5**

- **Reaction Setup:** In a reaction vessel, dissolve p-chlorophenol and a suitable catalyst (e.g., sodium hydroxide or a phase transfer catalyst like benzyltriethylammonium chloride) in an appropriate solvent (e.g., water).^{[21][22]}
- **Addition of Deuterated Glycidol:** Slowly add glycidol-d5 to the reaction mixture at a controlled temperature (e.g., 50-70°C).^{[21][22]}
- **Reaction Monitoring:** Monitor the reaction progress using thin-layer chromatography (TLC) or liquid chromatography-mass spectrometry (LC-MS).
- **Workup and Purification:** After the reaction is complete, perform an aqueous workup to remove the catalyst and unreacted starting materials. The product can then be purified by recrystallization or column chromatography.^{[21][23]}

Analytical Characterization

The successful synthesis and purity of deuterated chlorphenesin must be confirmed using various analytical techniques.

Table 2: Analytical Methods for Characterization

Analytical Technique	Purpose	Expected Outcome
Mass Spectrometry (MS)	Confirm molecular weight and isotopic enrichment.	A molecular ion peak corresponding to the mass of chlorphenesin plus the mass of the incorporated deuterium atoms.
Nuclear Magnetic Resonance (NMR) Spectroscopy	Determine the location and extent of deuteration.	Absence of proton signals at the deuterated positions in the ^1H NMR spectrum. Presence of corresponding signals in the ^2H NMR spectrum.
High-Performance Liquid Chromatography (HPLC)	Assess purity.	A single major peak indicating a high-purity compound.

In Vitro and In Vivo Evaluation

A series of in vitro and in vivo experiments are necessary to compare the properties of deuterated chlorphenesin to its non-deuterated counterpart.

In Vitro Assays

Table 3: Key In Vitro Experimental Protocols

Assay	Objective	Detailed Methodology
Metabolic Stability Assay	To compare the rate of metabolism of deuterated vs. non-deuterated chlorphenesin.	<ol style="list-style-type: none"> 1. Incubation: Incubate deuterated and non-deuterated chlorphenesin with liver microsomes (human, rat) or hepatocytes. 2. Sampling: Collect samples at various time points. 3. Analysis: Quench the reaction and analyze the remaining parent compound concentration using LC-MS/MS.[24] 4. Calculation: Determine the half-life ($t_{1/2}$) and intrinsic clearance (CL_{int}).
Antimicrobial Susceptibility Testing	To determine if deuteration affects the antimicrobial efficacy.	<ol style="list-style-type: none"> 1. Preparation: Prepare serial dilutions of both compounds in appropriate growth media. 2. Inoculation: Inoculate with standardized suspensions of relevant microorganisms (e.g., <i>S. aureus</i>, <i>E. coli</i>, <i>C. albicans</i>). 3. Incubation: Incubate under appropriate conditions. 4. Determination of MIC: Determine the Minimum Inhibitory Concentration (MIC) by observing the lowest concentration that inhibits visible growth.[19]
Immunomodulation Assay (T-cell Proliferation)	To assess the impact of deuteration on the immunosuppressive activity.	<ol style="list-style-type: none"> 1. Cell Culture: Culture primary T-lymphocytes or a T-cell line. 2. Stimulation: Stimulate the cells with a mitogen (e.g., PHA or anti-CD3/CD28 antibodies). 3. Treatment: Treat the cells with varying concentrations of

deuterated and non-deuterated chlorphenesin. 4. Proliferation Measurement: Measure cell proliferation using assays such as BrdU incorporation or CFSE dilution by flow cytometry.[16] [19]

In Vivo Studies

Table 4: Key In Vivo Experimental Protocols

Study Type	Objective	Detailed Methodology
Pharmacokinetic (PK) Study	To compare the absorption, distribution, metabolism, and excretion (ADME) profiles.	<ol style="list-style-type: none">1. Animal Model: Use a suitable animal model (e.g., rats or mice).2. Dosing: Administer a single dose of each compound (intravenous and oral).3. Blood Sampling: Collect blood samples at predetermined time points.4. Analysis: Analyze plasma concentrations of the parent drug and major metabolites using LC-MS/MS.^[24]5. PK Parameter Calculation: Calculate key PK parameters such as C_{max}, T_{max}, AUC, and half-life.^{[10][25]}
Muscle Relaxant Efficacy Model	To evaluate if deuteration enhances the muscle relaxant effect.	<ol style="list-style-type: none">1. Model: Use an established model of muscle spasm in rodents (e.g., inclined screen test or rotarod test).2. Treatment: Administer deuterated or non-deuterated chlorphenesin.3. Assessment: Measure the ability of the animals to remain on the screen or rod over time, indicating muscle relaxation.

Signaling Pathways and Visualizations

Chlorphenesin is known to influence several signaling pathways. Understanding these pathways is crucial for interpreting the effects of its deuterated analog.

Immunomodulatory Signaling Pathway

In T-lymphocytes, chlorphenesin is suggested to exert its immunosuppressive effects by inhibiting the PI3K/Akt signaling pathway, which is crucial for T-cell activation, proliferation, and survival.[20]

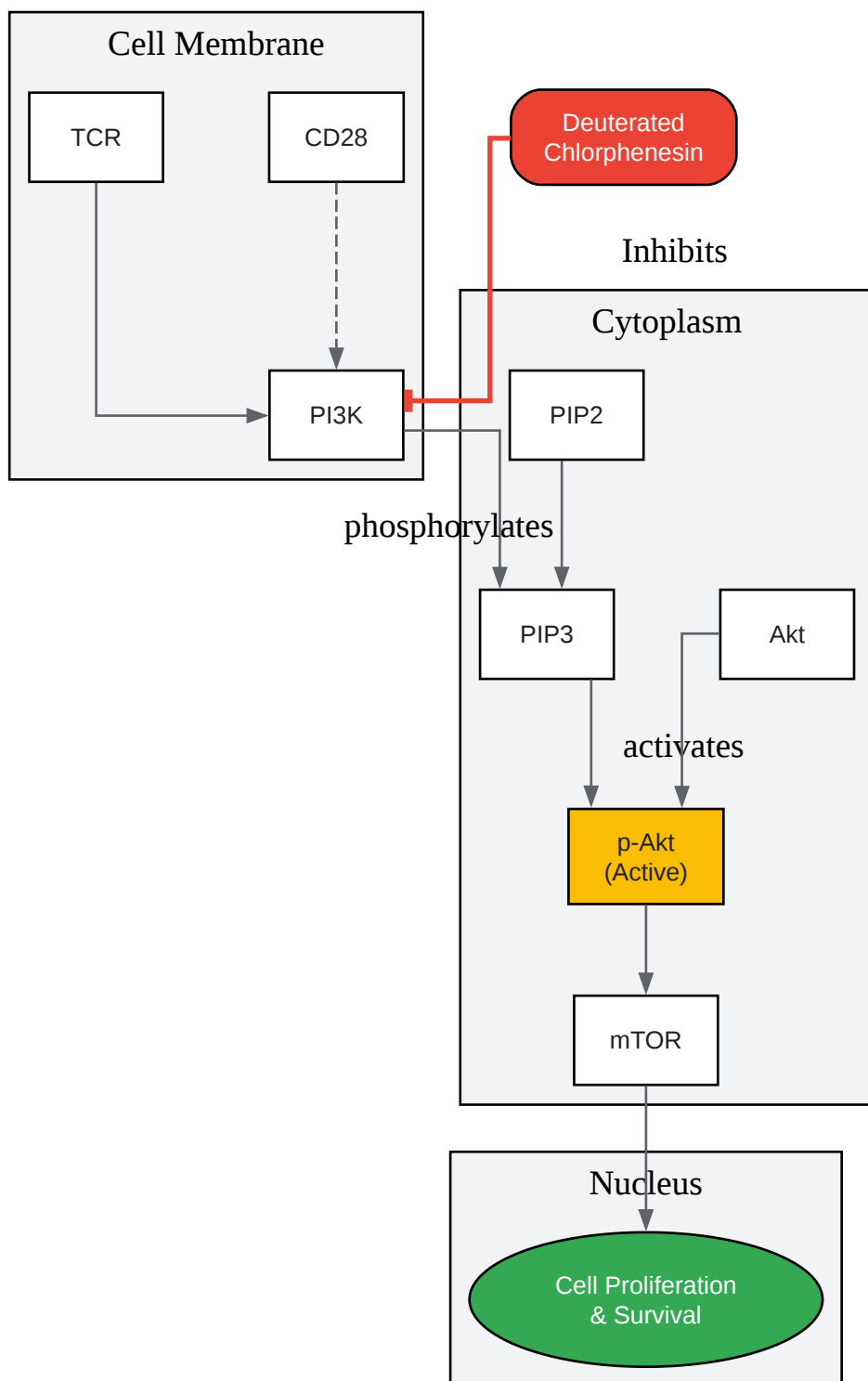

[Click to download full resolution via product page](#)

Caption: Proposed inhibition of the PI3K/Akt pathway by deuterated chlorphenesin.

Central Nervous System Action

The muscle relaxant properties of chlorphenesin are mediated through its action on the central nervous system, likely by depressing polysynaptic reflexes in the spinal cord.[3]

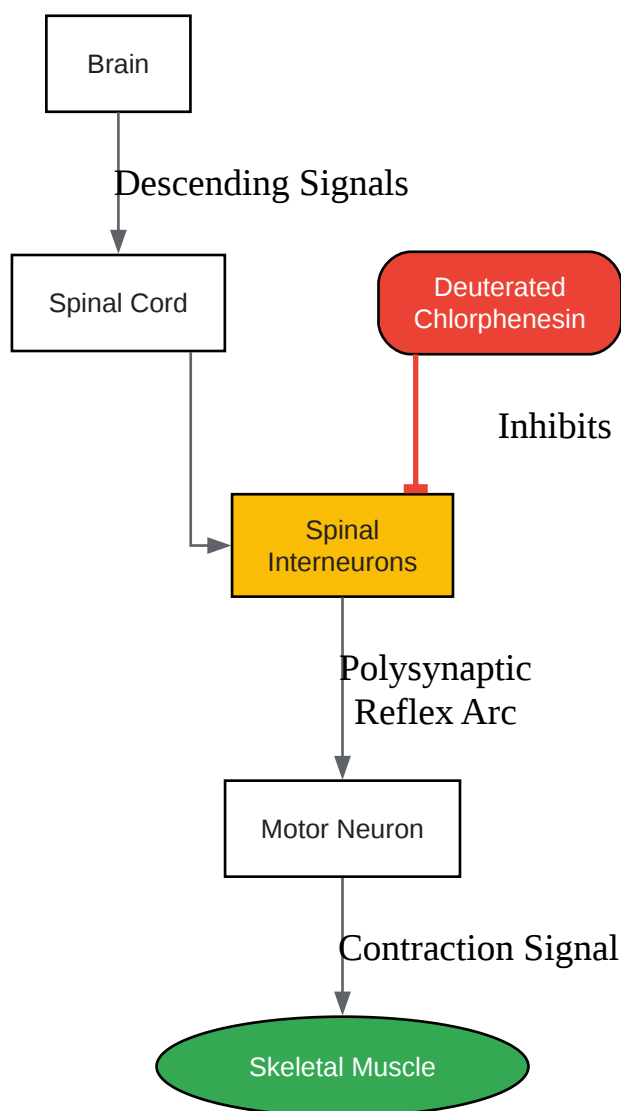

[Click to download full resolution via product page](#)

Caption: CNS mechanism of action for deuterated chlorphenesin.

Experimental Workflow

The following diagram outlines a comprehensive workflow for the research and development of deuterated chlorphenesin.

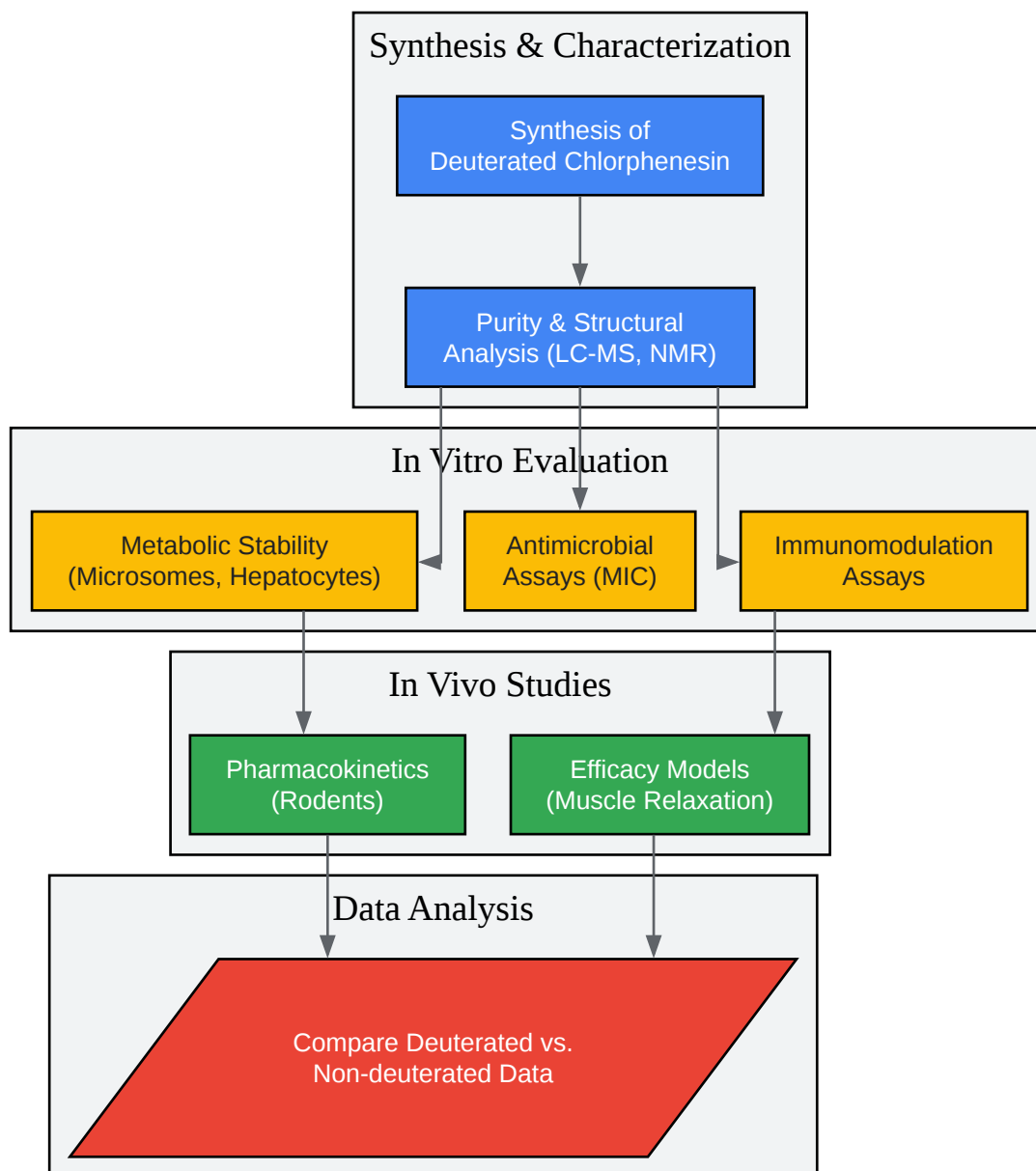

[Click to download full resolution via product page](#)

Caption: R&D workflow for deuterated chlorphenesin.

Conclusion

Deuterated chlorphenesin represents a promising research tool for scientists and drug development professionals. By leveraging the kinetic isotope effect, researchers can potentially create a molecule with improved metabolic stability, a longer duration of action, and a more favorable safety profile. The experimental protocols and conceptual frameworks provided in this guide offer a clear path for the synthesis, characterization, and evaluation of this novel compound. Further investigation into deuterated chlorphenesin could unlock new therapeutic possibilities and provide deeper insights into its multifaceted biological activities.

Need Custom Synthesis?

BenchChem offers custom synthesis for rare earth carbides and specific isotopic labeling.

Email: info@benchchem.com or [Request Quote Online](#).

References

- [1. Deuterium in drug discovery: progress, opportunities and challenges - PMC \[pmc.ncbi.nlm.nih.gov\]](#)
- [2. Accelerating Drug Discovery with Deuterated Labelled Compounds - AquigenBio \[aquigenbio.com\]](#)
- [3. benchchem.com \[benchchem.com\]](#)
- [4. cir-safety.org \[cir-safety.org\]](#)
- [5. Chlorphenesin | C₉H₁₁ClO₃ | CID 7697 - PubChem \[pubchem.ncbi.nlm.nih.gov\]](#)
- [6. clearsynthdiscovery.com \[clearsynthdiscovery.com\]](#)
- [7. Benefits and Mechanisms of Deuterated Drugs | Enhanced Efficacy \[bocsci.com\]](#)
- [8. juniperpublishers.com \[juniperpublishers.com\]](#)
- [9. deutramed.com \[deutramed.com\]](#)
- [10. Impact of Deuterium Substitution on the Pharmacokinetics of Pharmaceuticals - PubMed \[pubmed.ncbi.nlm.nih.gov\]](#)
- [11. researchgate.net \[researchgate.net\]](#)
- [12. Chlorphenesin carbamate \(maolate\) in the relief of muscle pain - PubMed \[pubmed.ncbi.nlm.nih.gov\]](#)
- [13. Chlorphenesin carbamate - Wikipedia \[en.wikipedia.org\]](#)

- 14. In vitro study to evaluate the antimicrobial activity of various multifunctional cosmetic ingredients and chlorphenesin on bacterial species at risk in the cosmetic industry - PubMed [pubmed.ncbi.nlm.nih.gov]
- 15. Chlorphenesin (Explained + Products) [incidecoder.com]
- 16. cir-safety.org [cir-safety.org]
- 17. Chlorphenesin | Antifungal | Histamine Receptor | TargetMol [targetmol.com]
- 18. go.drugbank.com [go.drugbank.com]
- 19. benchchem.com [benchchem.com]
- 20. benchchem.com [benchchem.com]
- 21. CN113185384A - Synthesis method of high-purity odorless chlorphenesin - Google Patents [patents.google.com]
- 22. Synthesis method of high-purity odorless chlorphenesin - Eureka | Patsnap [eureka.patsnap.com]
- 23. CN101445436B - Preparation method of medical compound chlorphenesin - Google Patents [patents.google.com]
- 24. In-vivo tracking of deuterium metabolism in mouse organs using LC-MS/MS - PubMed [pubmed.ncbi.nlm.nih.gov]
- 25. researchgate.net [researchgate.net]
- To cite this document: BenchChem. [Deuterated Chlorphenesin as a Research Tool: An In-depth Technical Guide]. BenchChem, [2026]. [Online PDF]. Available at: [<https://www.benchchem.com/product/b15558525/docs#deuterated-chlorphenesin-as-a-research-tool-an-in-depth-technical-guide>]

Disclaimer & Data Validity:

The information provided in this document is for Research Use Only (RUO) and is strictly not intended for diagnostic or therapeutic procedures. While BenchChem strives to provide accurate protocols, we make no warranties, express or implied, regarding the fitness of this product for every specific experimental setup.

Technical Support: The protocols provided are for reference purposes. Unsure if this reagent suits your experiment?

Need Industrial/Bulk Grade? [Request Custom Synthesis Quote](#)

BenchChem

Our mission is to be the trusted global source of essential and advanced chemicals, empowering scientists and researchers to drive progress in science and industry.

Contact

Address: 3281 E Guasti Rd

Ontario, CA 91761, United States

Phone: (601) 213-4426

Email: info@benchchem.com

[Contact our Ph.D. Support Team for a compatibility check](#)