

Technical Support Center: Improving Dasatinib Recovery from Biological Matrices

Author: BenchChem Technical Support Team. **Date:** April 2026

Compound of Interest

Compound Name: *Dasatinib-d4*

Cat. No.: *B15557074*

[Get Quote](#)

This technical support center provides troubleshooting guidance and frequently asked questions (FAQs) to assist researchers, scientists, and drug development professionals in optimizing the recovery of Dasatinib from biological matrices.

Troubleshooting Guide

This guide addresses specific issues that may be encountered during the experimental process of Dasatinib extraction and analysis.

Issue 1: Low Recovery of Dasatinib from Plasma/Serum Samples

Possible Cause 1: Inefficient Protein Precipitation

- Question: My Dasatinib recovery is consistently low after performing a protein precipitation step with acetonitrile. What could be wrong?
- Answer: While acetonitrile is a common choice for protein precipitation, its efficiency can be influenced by the ratio of solvent to sample and the precipitation conditions.^{[1][2]} Dasatinib is reported to have high serum protein binding (>90%), which can make its extraction

challenging.[1] Incomplete precipitation will result in a lower concentration of free Dasatinib available for extraction.

◦ Troubleshooting Steps:

- Optimize Solvent-to-Sample Ratio: Experiment with different ratios of acetonitrile to your plasma or serum sample. A higher ratio (e.g., 3:1 or 4:1, v/v) may be necessary to achieve complete protein precipitation.
- Vortexing and Incubation: Ensure thorough vortexing after adding the precipitant to facilitate complete protein denaturation. An incubation step on ice for 10-15 minutes can further enhance precipitation.
- Centrifugation: Use a high centrifugation speed (e.g., >10,000 x g) for an adequate duration (e.g., 10-15 minutes) to ensure a clear separation of the supernatant from the precipitated protein pellet.[3]

Possible Cause 2: Suboptimal Liquid-Liquid Extraction (LLE) Parameters

- Question: I am using liquid-liquid extraction, but my Dasatinib recovery is poor. How can I improve it?
- Answer: The efficiency of LLE is highly dependent on the choice of organic solvent, the pH of the aqueous phase, and the extraction technique.[4][5]

◦ Troubleshooting Steps:

- Solvent Selection: Different organic solvents have varying polarities and extraction efficiencies for Dasatinib. While ethyl acetate has been used successfully, other solvents or mixtures could be more effective for your specific matrix.[4][6] Consider testing solvents like methyl tert-butyl ether or a mixture of ethyl acetate and tert-butyl methyl ether.[4][7]
- pH Adjustment: The charge state of Dasatinib can significantly impact its partitioning between the aqueous and organic phases. Dasatinib has pKa values of 3.1, 6.8, and 10.8.[8] Adjusting the pH of your sample to make Dasatinib more neutral may improve

its extraction into an organic solvent. For instance, alkalization with 1M NaOH has been reported before extraction with a dichloromethane/hexane mixture.[5]

- **Emulsion Formation:** Emulsions can form at the interface of the aqueous and organic layers, trapping the analyte and reducing recovery. To minimize emulsion formation, try gentle mixing instead of vigorous vortexing or consider adding a small amount of a de-emulsifying agent.

Possible Cause 3: Inadequate Solid-Phase Extraction (SPE) Protocol

- **Question:** My SPE protocol for Dasatinib is not yielding the expected recovery. What are the key parameters to check?
- **Answer:** SPE is a powerful technique but requires careful optimization of the sorbent, wash, and elution steps.
 - **Troubleshooting Steps:**
 - **Sorbent Selection:** The choice of SPE sorbent is critical. For Dasatinib, a reverse-phase sorbent like C18 is a common choice.[1][9] However, depending on the sample matrix, other sorbents like polymeric or ion-exchange cartridges might provide better cleanup and recovery.
 - **Conditioning and Equilibration:** Ensure the SPE cartridge is properly conditioned with an organic solvent (e.g., methanol) and then equilibrated with an aqueous solution (e.g., water or buffer) that matches the pH of your sample. This ensures proper interaction of the analyte with the sorbent.
 - **Wash and Elution Solvents:** The wash solvent should be strong enough to remove interferences without eluting Dasatinib. The elution solvent should be strong enough to completely desorb Dasatinib from the sorbent. You may need to optimize the composition and pH of both the wash and elution solvents.

Issue 2: High Variability in Dasatinib Recovery

Possible Cause 1: Inconsistent Sample Handling and Storage

- Question: I am observing significant variability in Dasatinib recovery between replicate samples. What could be the cause?
- Answer: Dasatinib stability can be affected by storage conditions and repeated freeze-thaw cycles.[\[1\]](#)[\[10\]](#) Inconsistent handling can lead to degradation and variable recovery.
 - Troubleshooting Steps:
 - Standardize Storage: Store plasma and serum samples at -20°C or -80°C until analysis. [\[1\]](#)[\[10\]](#) Avoid repeated freeze-thaw cycles, as more than six cycles from -20°C have been shown to be stable, but it's a good practice to aliquot samples into single-use tubes.[\[10\]](#)
 - Benchtop Stability: Be mindful of the time samples spend at room temperature during processing. Dasatinib is stable in human plasma for at least 22 hours at room temperature, but minimizing this time is recommended.[\[10\]](#)
 - Internal Standard: Use a stable, deuterated internal standard like Dasatinib-d8 to compensate for variability in extraction and instrument response.[\[3\]](#)

Possible Cause 2: Matrix Effects in LC-MS/MS Analysis

- Question: My LC-MS/MS results for Dasatinib are inconsistent. Could this be due to matrix effects?
- Answer: Yes, matrix components from biological samples can co-elute with Dasatinib and suppress or enhance its ionization in the mass spectrometer, leading to inaccurate and variable results.[\[6\]](#)[\[11\]](#)
 - Troubleshooting Steps:
 - Improve Sample Cleanup: Employ a more rigorous sample preparation method like SPE or LLE instead of simple protein precipitation to remove more matrix components.[\[4\]](#)
 - Chromatographic Separation: Optimize your HPLC/UPLC method to achieve better separation of Dasatinib from interfering matrix components. This may involve changing the column, mobile phase composition, or gradient profile.[\[2\]](#)[\[9\]](#)

- Matrix Effect Evaluation: Perform post-extraction addition experiments to quantify the extent of ion suppression or enhancement in your method.

Frequently Asked Questions (FAQs)

- Q1: What is the most common method for extracting Dasatinib from plasma?
 - A1: Protein precipitation (PPT) with acetonitrile or methanol is a widely used and simple method for Dasatinib extraction from plasma.[1][2][3] However, for cleaner extracts and potentially higher recovery, liquid-liquid extraction (LLE) and solid-phase extraction (SPE) are also commonly employed.[4][7][8]
- Q2: What are the expected recovery rates for Dasatinib from human plasma?
 - A2: Recovery rates can vary depending on the extraction method and the laboratory. One study using protein precipitation with acetonitrile reported mean overall recovery of $106.6\% \pm 4.7\%$. [1] Another study using LLE with ethyl acetate did not explicitly state the recovery percentage but demonstrated good accuracy and precision. [6] A different LC-MS/MS method reported average recoveries ranging from 79.77% to 85.17%. [11]
- Q3: How stable is Dasatinib in plasma under different storage conditions?
 - A3: Dasatinib is generally stable in human plasma. It has been shown to be stable for at least 22 hours at room temperature, for at least 123 days at -20°C , and through at least six freeze-thaw cycles from -20°C . [1][10]
- Q4: What internal standard is recommended for the bioanalysis of Dasatinib?
 - A4: A stable isotope-labeled internal standard, such as Dasatinib-d8, is highly recommended to ensure the accuracy and precision of the assay by compensating for matrix effects and variability in extraction and instrument response. [3] Imatinib has also been used as an internal standard in some HPLC-UV methods. [1]
- Q5: What are the key signaling pathways inhibited by Dasatinib?
 - A5: Dasatinib is a potent inhibitor of multiple tyrosine kinases. Its primary targets include BCR-ABL, the SRC family kinases (SRC, LCK, YES, FYN), c-KIT, and PDGFR β . [12][13]

Inhibition of these pathways is central to its therapeutic effect in chronic myeloid leukemia (CML) and other cancers.

Data Presentation

Table 1: Summary of Dasatinib Stability in Human Plasma

Storage Condition	Duration	Stability Outcome	Reference
Room Temperature	At least 22 hours	Stable	[10]
-20°C	At least 123 days	Stable	[10]
Freeze-Thaw Cycles (from -20°C)	At least 6 cycles	Stable	[10]
Auto-sampler (5°C)	Not specified	Stable	[1]

Table 2: Comparison of Dasatinib Extraction Methods and Recovery

Extraction Method	Matrix	Key Reagents	Mean Recovery (%)	Reference
Protein Precipitation	Human Plasma	Acetonitrile	106.6 ± 4.7	[1]
Protein Precipitation	Human Plasma	Methanol with 0.1% formic acid	Not explicitly stated, but method was successful	[3]
Liquid-Liquid Extraction	Human Plasma	Ethyl acetate	Not explicitly stated, but method was successful	[6]
Liquid-Liquid Extraction	Rat Plasma	Methyl tert-butyl ether	Not explicitly stated, but method was successful	[7]
Spectrophotometric Method with LLE	Human Plasma	Methanol (for PPT), 1M NaOH, 30% Dichloromethane in Hexane	99.86% - 99.9%	[5]
UPLC-MS/MS	Rat Plasma	Not specified	79.77% - 85.17%	[11]

Experimental Protocols

1. Protein Precipitation using Acetonitrile[1]

- To a 200 µL aliquot of human plasma in a microcentrifuge tube, add a known amount of internal standard (e.g., Imatinib).
- Add 600 µL of acetonitrile to precipitate the plasma proteins.
- Vortex the mixture for 1 minute.

- Centrifuge the sample at 10,000 rpm for 10 minutes.
- Carefully transfer the supernatant to a clean tube.
- Inject an aliquot of the supernatant into the HPLC system for analysis.

2. Liquid-Liquid Extraction using Ethyl Acetate[6]

- To a 300 μ L aliquot of human plasma, add 60 μ L of the internal standard working solution and 50 μ L of 0.1 M sodium hydroxide solution.
- Vortex the mixture for 2 minutes.
- Add 1.2 mL of ethyl acetate and vortex thoroughly for 5 minutes.
- Centrifuge the mixture at 15,000 rpm at 4°C for 10 minutes.
- Transfer the upper organic layer to a clean tube.
- Evaporate the organic solvent to dryness under a stream of nitrogen at 35°C.
- Reconstitute the residue in a suitable mobile phase for LC-MS/MS analysis.

Visualizations

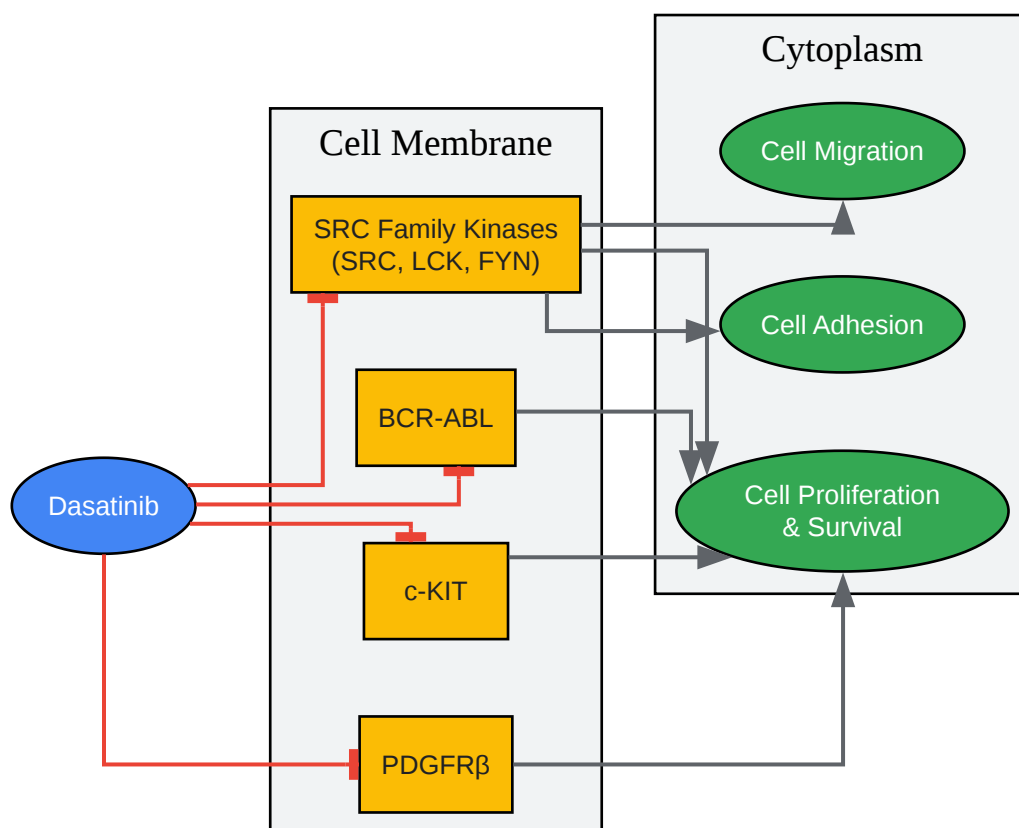

[Click to download full resolution via product page](#)

Caption: Dasatinib signaling pathway inhibition.

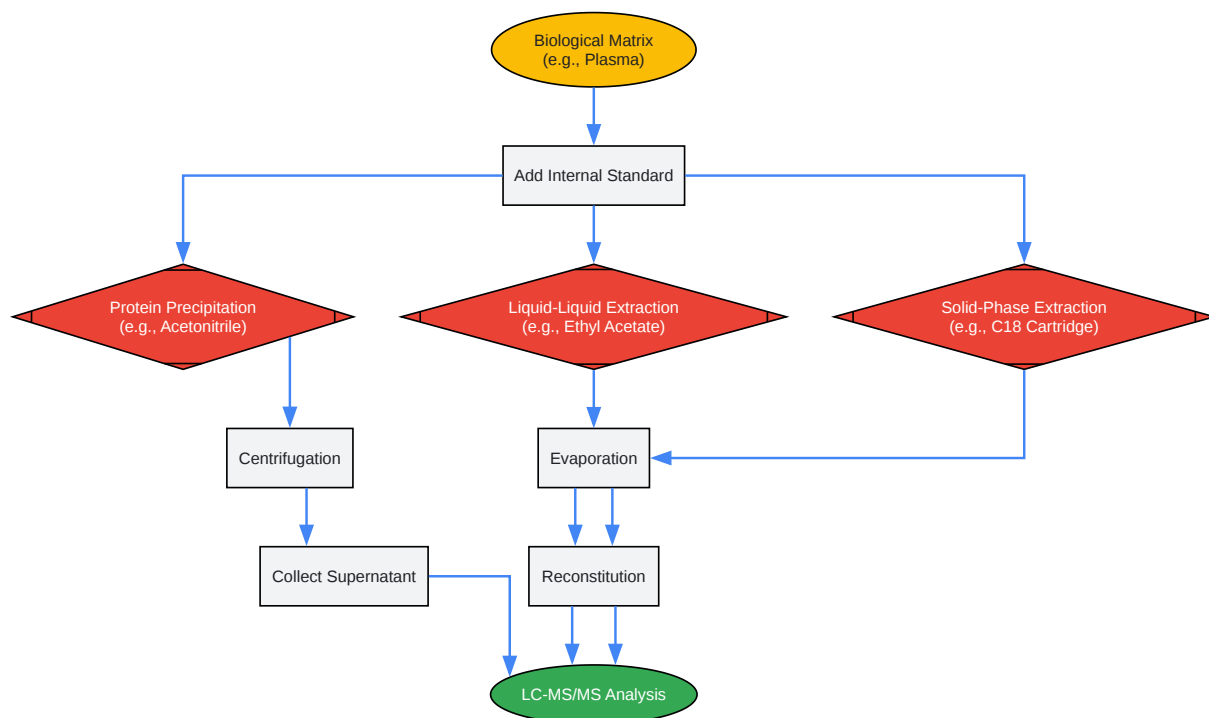

[Click to download full resolution via product page](#)

Caption: General workflow for Dasatinib extraction.

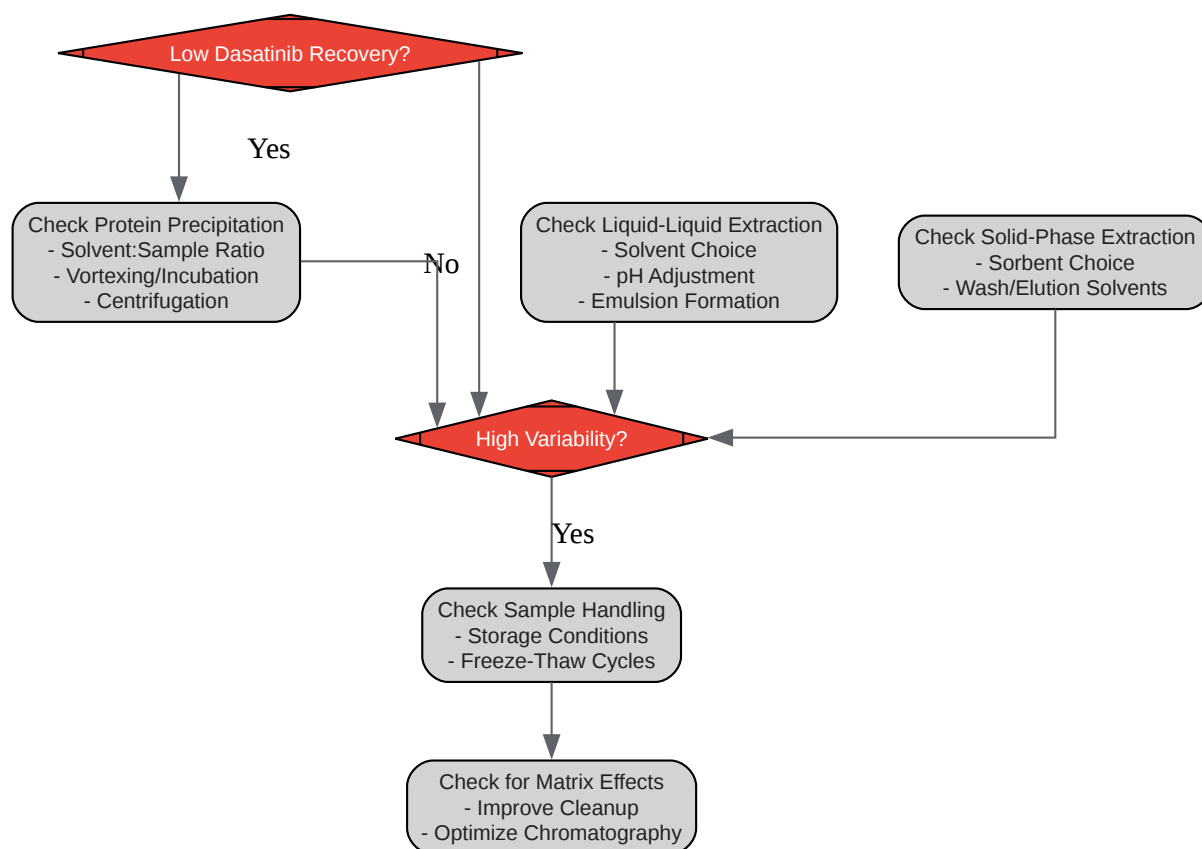

[Click to download full resolution via product page](#)

Caption: Troubleshooting logic for Dasatinib recovery.

Need Custom Synthesis?

BenchChem offers custom synthesis for rare earth carbides and specific isotopic labeling.

Email: info@benchchem.com or [Request Quote Online](#).

References

- [1. acgpubs.org \[acgpubs.org\]](http://1.acgpubs.org)
- [2. tandfonline.com \[tandfonline.com\]](http://2.tandfonline.com)

- [3. vibgyorpublishers.org](http://3.vibgyorpublishers.org) [vibgyorpublishers.org]
- [4. researchgate.net](http://4.researchgate.net) [researchgate.net]
- [5. chemconsai.com](http://5.chemconsai.com) [chemconsai.com]
- [6. A validated UPLC–MS/MS method for simultaneous determination of imatinib, dasatinib and nilotinib in human plasma - PMC](#) [pmc.ncbi.nlm.nih.gov]
- [7. scielo.br](http://7.scielo.br) [scielo.br]
- [8. researchgate.net](http://8.researchgate.net) [researchgate.net]
- [9. Formulation Characterization and Pharmacokinetic Evaluation of Amorphous Solid Dispersions of Dasatinib](#) [mdpi.com]
- [10. benchchem.com](http://10.benchchem.com) [benchchem.com]
- [11. impactfactor.org](http://11.impactfactor.org) [impactfactor.org]
- [12. media.cellsignal.com](http://12.media.cellsignal.com) [media.cellsignal.com]
- [13. A narrative review on adverse effects of dasatinib with a focus on pharmacotherapy of dasatinib-induced pulmonary toxicities - PMC](#) [pmc.ncbi.nlm.nih.gov]
- To cite this document: BenchChem. [Technical Support Center: Improving Dasatinib Recovery from Biological Matrices]. BenchChem, [2026]. [Online PDF]. Available at: [<https://www.benchchem.com/product/b15557074/docs#technical-support-center-improving-dasatinib-recovery-from-biological-matrices>]

Disclaimer & Data Validity:

The information provided in this document is for Research Use Only (RUO) and is strictly not intended for diagnostic or therapeutic procedures. While BenchChem strives to provide accurate protocols, we make no warranties, express or implied, regarding the fitness of this product for every specific experimental setup.

Technical Support: The protocols provided are for reference purposes. Unsure if this reagent suits your experiment?

Need Industrial/Bulk Grade? [Request Custom Synthesis Quote](#)

BenchChem

Our mission is to be the trusted global source of essential and advanced chemicals, empowering scientists and researchers to drive progress in science and industry.

Contact

Address: 3281 E Guasti Rd

Ontario, CA 91761, United States

Phone: (601) 213-4426

Email: info@benchchem.com

[Contact our Ph.D. Support Team for a compatibility check](#)