

# Sulfo-Cy5 Azide: A Comprehensive Technical Guide for Advanced Bio-labeling

**Author:** BenchChem Technical Support Team. **Date:** April 2026

## Compound of Interest

Compound Name: Sulfo-Cy5 azide

Cat. No.: B15556027

[Get Quote](#)

For Researchers, Scientists, and Drug Development Professionals

This in-depth technical guide explores the core features, benefits, and applications of **Sulfo-Cy5 azide**, a water-soluble, near-infrared fluorescent probe. Designed for high-performance bioconjugation, this reagent has become an indispensable tool in molecular biology, drug development, and diagnostics. This document provides a detailed overview of its properties, experimental protocols for its use in click chemistry, and visualizations of key chemical processes.

## Core Features and Benefits

**Sulfo-Cy5 azide** is a derivative of the popular Cy5 dye, modified with sulfonate groups and an azide functional group. This unique chemical structure imparts several advantageous properties for researchers.

The presence of sulfonate groups renders the molecule highly soluble in aqueous buffers, which is critical when working with sensitive biological samples like proteins that can be denatured by organic co-solvents.[1][2] This hydrophilicity also minimizes non-specific binding that can lead to background noise in imaging applications.[3]

Operating in the near-infrared spectrum, **Sulfo-Cy5 azide** offers significant advantages for biological imaging.[1] Its long excitation and emission wavelengths allow for deeper tissue penetration and result in reduced background autofluorescence from endogenous biomolecules, leading to a higher signal-to-noise ratio.[1][4] The dye also possesses a high molar extinction coefficient, contributing to its bright fluorescence and enabling sensitive detection of target molecules.[3]

The azide functional group is bioorthogonal, meaning it does not react with functional groups typically found in biological systems.[1] This ensures highly specific labeling of molecules that have been modified to contain a complementary alkyne group. This specificity is leveraged in "click chemistry" reactions.[5][6]

## Quantitative Data Summary

The photophysical and chemical properties of **Sulfo-Cy5 azide** and its variants are summarized in the table below for easy comparison. These values are critical for designing experiments and selecting appropriate instrumentation.

Property	Sulfo-Cy5 Azide	Sulfo-Cy5.5 Azide	Reference(s)
Molecular Weight	~833 g/mol	~999.2 g/mol	[7][8][9]
Excitation Maximum ( $\lambda_{ex}$ )	~647 nm	~678 nm	[7][9]
Emission Maximum ( $\lambda_{em}$ )	~663 nm	~694 nm	[7][9]
Molar Extinction Coefficient ( $\epsilon$ )	~250,000 L·mol <sup>-1</sup> ·cm <sup>-1</sup>	~190,000 L·mol <sup>-1</sup> ·cm <sup>-1</sup>	[8][9]
Quantum Yield ( $\Phi$ )	0.2	Not specified	[10]
Solubility	Water, DMSO, DMF	Water, DMSO, DMF	[7][8][9]

## Key Applications

The primary application of **Sulfo-Cy5 azide** is the fluorescent labeling of biomolecules via click chemistry. This includes:

- Labeling and imaging of RNA and other nucleic acids.[\[2\]](#)[\[5\]](#)
- Fluorescent labeling of proteins, peptides, and antibodies.[\[2\]](#)[\[8\]](#)
- In vitro and in vivo tracking of exosomes and other extracellular vesicles.[\[1\]](#)
- Generation of targeted, pH-responsive polymeric nanoparticles for drug delivery.[\[11\]](#)
- Development of bimodal theranostic agents for targeted cancer therapy and diagnosis.[\[12\]](#)

## Experimental Protocols

**Sulfo-Cy5 azide** is most commonly used in copper(I)-catalyzed azide-alkyne cycloaddition (CuAAC), a type of click chemistry. Below is a detailed protocol for the fluorescent labeling of an alkyne-modified protein.

### Protocol: Copper-Catalyzed Click Chemistry (CuAAC) Labeling of an Alkyne-Modified Protein

Materials:

- Alkyne-modified protein in a suitable buffer (e.g., phosphate-buffered saline, pH 7.4)
- **Sulfo-Cy5 Azide**
- Dimethyl sulfoxide (DMSO)
- Copper(II) sulfate ( $\text{CuSO}_4$ )
- Tris(3-hydroxypropyltriazolylmethyl)amine (THPTA) ligand
- Sodium ascorbate
- Purification column (e.g., size-exclusion chromatography)
- Microcentrifuge tubes

Procedure:

- Prepare Stock Solutions:
  - **Sulfo-Cy5 Azide**: Dissolve **Sulfo-Cy5 azide** in DMSO to a final concentration of 10 mM. [\[1\]](#)
  - Copper(II) Sulfate (CuSO<sub>4</sub>): Prepare a 20 mM stock solution in water. [\[13\]](#)
  - THPTA Ligand: Prepare a 100 mM stock solution in water. [\[13\]](#)
  - Sodium Ascorbate: Prepare a fresh 100 mM solution in water immediately before use. [\[13\]](#)
- Reaction Setup:
  - In a microcentrifuge tube, add the alkyne-modified protein to the desired final concentration in your reaction buffer.
  - Add the **Sulfo-Cy5 azide** stock solution to the protein solution. A 1.5 to 2-fold molar excess of the azide over the protein is a good starting point. [\[13\]](#)
  - In a separate tube, prepare the catalyst premix by combining the CuSO<sub>4</sub> and THPTA solutions. A 1:5 molar ratio of CuSO<sub>4</sub> to THPTA is common. [\[1\]](#)[\[13\]](#)
  - Add the catalyst premix to the reaction mixture. A final copper concentration of 50-100 μM is often sufficient. [\[1\]](#)[\[13\]](#)
  - Initiate the reaction by adding the freshly prepared sodium ascorbate solution to a final concentration of 1-5 mM. [\[1\]](#)[\[13\]](#)
- Incubation:
  - Gently mix the reaction and incubate at room temperature for 30-60 minutes, protected from light. [\[1\]](#)
- Purification:
  - Remove unreacted dye and other reaction components by a suitable purification method, such as size-exclusion chromatography. [\[1\]](#)

## Visualizing the Chemistry

To better understand the processes involved in using **Sulfo-Cy5 azide**, the following diagrams illustrate the key chemical reaction and a troubleshooting workflow.

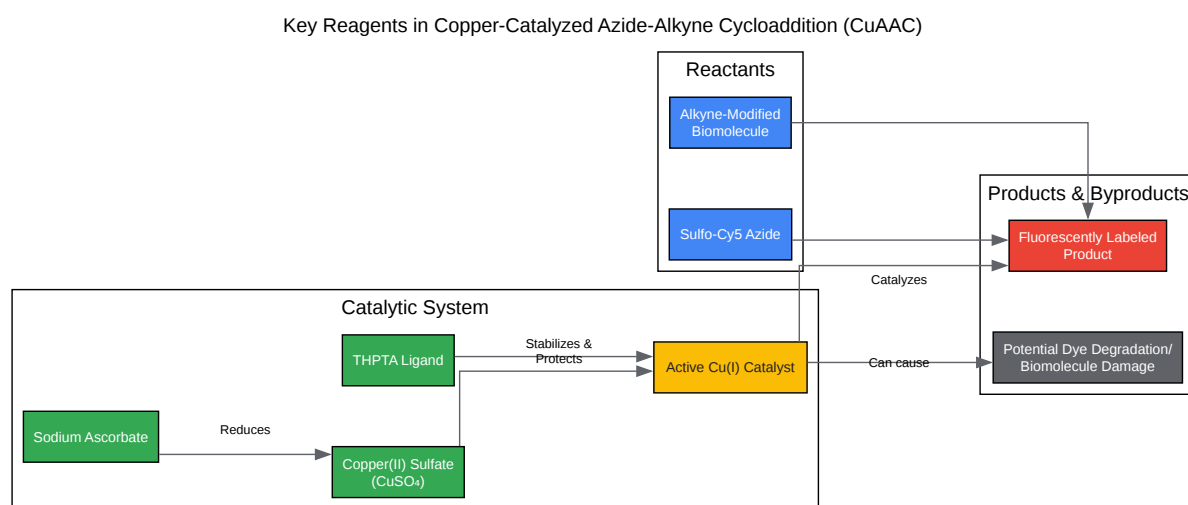

[Click to download full resolution via product page](#)

Caption: The roles and relationships of key reagents in the CuAAC reaction.

## Troubleshooting Workflow for Low-Yield CuAAC Reactions

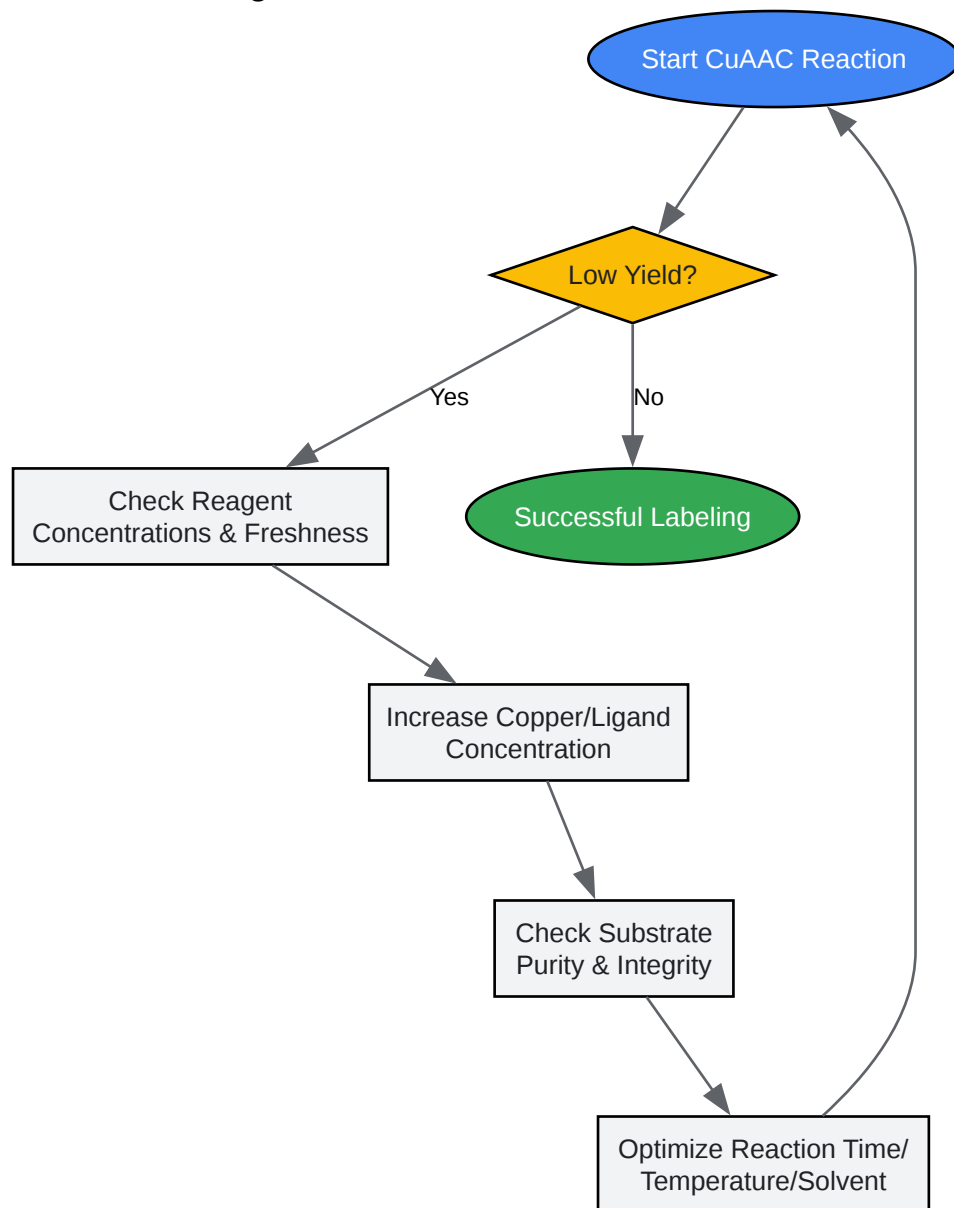

[Click to download full resolution via product page](#)

Caption: A logical workflow for troubleshooting low-yield CuAAC reactions.

**Need Custom Synthesis?**

BenchChem offers custom synthesis for rare earth carbides and specific isotopic labeling.

Email: [info@benchchem.com](mailto:info@benchchem.com) or [Request Quote Online](#).

## References

- [1. benchchem.com \[benchchem.com\]](#)
- [2. apexbt.com \[apexbt.com\]](#)
- [3. lumiprobe.com \[lumiprobe.com\]](#)
- [4. vectorlabs.com \[vectorlabs.com\]](#)
- [5. medchemexpress.com \[medchemexpress.com\]](#)
- [6. Sulfo Cy5 Azide | AxisPharm \[axispharm.com\]](#)
- [7. Sulfo-Cy5-Azide, Azide-containing Fluorescent Dyes - Jena Bioscience \[jenabioscience.com\]](#)
- [8. Sulfo-Cy5 Azide, 1782950-80-4 | BroadPharm \[broadpharm.com\]](#)
- [9. Sulfo-Cy5.5 Azide, 1801695-56-6 | BroadPharm \[broadpharm.com\]](#)
- [10. ibiantech.com \[ibiantech.com\]](#)
- [11. research.ed.ac.uk \[research.ed.ac.uk\]](#)
- [12. Polypeptide-Based Molecular Platform and Its Docetaxel/Sulfo-Cy5-Containing Conjugate for Targeted Delivery to Prostate Specific Membrane Antigen - PMC \[pmc.ncbi.nlm.nih.gov\]](#)
- [13. benchchem.com \[benchchem.com\]](#)
- To cite this document: BenchChem. [Sulfo-Cy5 Azide: A Comprehensive Technical Guide for Advanced Bio-labeling]. BenchChem, [2026]. [Online PDF]. Available at: [<https://www.benchchem.com/product/b15556027/docs#sulfo-cy5-azide-a-comprehensive-technical-guide-for-advanced-bio-labeling>]

---

### Disclaimer & Data Validity:

The information provided in this document is for Research Use Only (RUO) and is strictly not intended for diagnostic or therapeutic procedures. While BenchChem strives to provide accurate protocols, we make no warranties, express or implied, regarding the fitness of this product for every specific experimental setup.

**Technical Support:** The protocols provided are for reference purposes. Unsure if this reagent suits your experiment?

**Need Industrial/Bulk Grade?** [Request Custom Synthesis Quote](#)

## BenchChem

Our mission is to be the trusted global source of essential and advanced chemicals, empowering scientists and researchers to drive progress in science and industry.

### Contact

Address: 3281 E Guasti Rd  
Ontario, CA 91761, United States  
Phone: (601) 213-4426  
Email: [info@benchchem.com](mailto:info@benchchem.com)

[Contact our Ph.D. Support Team for a compatibility check](#)