

# Labeling Oligonucleotides with Sulfo-Cy5 Azide: Application Notes and Protocols

**Author:** BenchChem Technical Support Team. **Date:** April 2026

## Compound of Interest

Compound Name: Sulfo-Cy5 azide

Cat. No.: B15556027

[Get Quote](#)

For Researchers, Scientists, and Drug Development Professionals

## Introduction

The covalent attachment of fluorescent dyes to oligonucleotides is a cornerstone technique in molecular biology, enabling a wide range of applications from in vitro diagnostics to in vivo imaging. **Sulfo-Cy5 azide** is a water-soluble, bright, far-red fluorescent dye ideally suited for labeling oligonucleotides. Its azide functional group allows for highly specific and efficient conjugation to alkyne-modified oligonucleotides via "click chemistry," a bioorthogonal reaction that proceeds with high yield under mild, aqueous conditions. This document provides detailed protocols for labeling oligonucleotides with **Sulfo-Cy5 azide**, purification of the conjugate, and its application in studying protein-DNA interactions.

Sulfo-Cy5 exhibits strong absorption and emission in the red and far-red region of the spectrum, minimizing background fluorescence from biological samples. The sulfonate groups enhance its water solubility, making it compatible with biological buffers and reducing the need for organic co-solvents that can be detrimental to the structure and function of biomolecules.

## Key Features of Sulfo-Cy5 Azide

Property	Value
Molecular Weight	833.01 g/mol [1][2]
Excitation Maximum (Ex)	~647-648 nm[3]
Emission Maximum (Em)	~655-671 nm[2][3]
Extinction Coefficient	~250,000 cm <sup>-1</sup> M <sup>-1</sup> [3]
Reactive Group	Azide (-N <sub>3</sub> )
Solubility	Water, DMSO, DMF[2][3]

## Experimental Protocols

This section details the protocols for labeling an alkyne-modified oligonucleotide with **Sulfo-Cy5 azide** using the copper(I)-catalyzed azide-alkyne cycloaddition (CuAAC) reaction, followed by purification and characterization of the labeled product.

### Protocol 1: Copper-Catalyzed Azide-Alkyne Cycloaddition (CuAAC) Labeling

This protocol describes the labeling of an alkyne-modified oligonucleotide with **Sulfo-Cy5 azide**.

Materials and Reagents:

- Alkyne-modified oligonucleotide
- **Sulfo-Cy5 azide**
- Anhydrous Dimethyl Sulfoxide (DMSO)
- Nuclease-free water
- Copper(II) sulfate (CuSO<sub>4</sub>)
- Tris(3-hydroxypropyltriazolylmethyl)amine (THPTA) or Tris(benzyltriazolylmethyl)amine (TBTA)

- Sodium ascorbate
- 2 M Triethylammonium acetate (TEAA) buffer, pH 7.0
- Microcentrifuge tubes

#### Reagent Preparation:

- Alkyne-Oligonucleotide Stock Solution: Dissolve the lyophilized alkyne-modified oligonucleotide in nuclease-free water to a final concentration of 1 mM.
- **Sulfo-Cy5 Azide** Stock Solution: Dissolve **Sulfo-Cy5 azide** in anhydrous DMSO to a final concentration of 10 mM. Store in the dark at -20°C.
- Copper(II) Sulfate Stock Solution: Prepare a 100 mM solution of CuSO<sub>4</sub> in nuclease-free water.
- Ligand Stock Solution (THPTA or TBTA): Prepare a 100 mM solution of the chosen ligand in nuclease-free water (for THPTA) or DMSO (for TBTA).
- Sodium Ascorbate Stock Solution: Freshly prepare a 1 M solution of sodium ascorbate in nuclease-free water immediately before use.

#### Labeling Reaction Procedure:

- In a microcentrifuge tube, combine the following reagents in the order listed:
  - Nuclease-free water to bring the final reaction volume to 100 µL.
  - 10 µL of 1 mM alkyne-oligonucleotide.
  - 20 µL of 2 M TEAA buffer, pH 7.0.
  - 1.5 µL of 10 mM **Sulfo-Cy5 azide** stock solution (1.5-fold molar excess).
- Vortex the mixture gently.
- Prepare the catalyst premix in a separate tube:

- 1  $\mu\text{L}$  of 100 mM  $\text{CuSO}_4$  stock solution.
- 5  $\mu\text{L}$  of 100 mM ligand stock solution.
- Vortex the catalyst premix and add it to the reaction mixture.
- Initiate the reaction by adding 5  $\mu\text{L}$  of freshly prepared 1 M sodium ascorbate.
- Vortex the reaction mixture gently and incubate at room temperature for 1-4 hours, protected from light.

#### Quantitative Parameters for CuAAC Labeling:

Parameter	Recommended Value
Oligonucleotide Concentration	100 $\mu\text{M}$
Sulfo-Cy5 Azide Molar Excess	1.5 - 5 fold
Copper(II) Sulfate Concentration	1 mM
Ligand Concentration	5 mM
Sodium Ascorbate Concentration	50 mM
Reaction Time	1 - 4 hours
Reaction Temperature	Room Temperature (20-25°C)
Typical Labeling Efficiency	> 90%

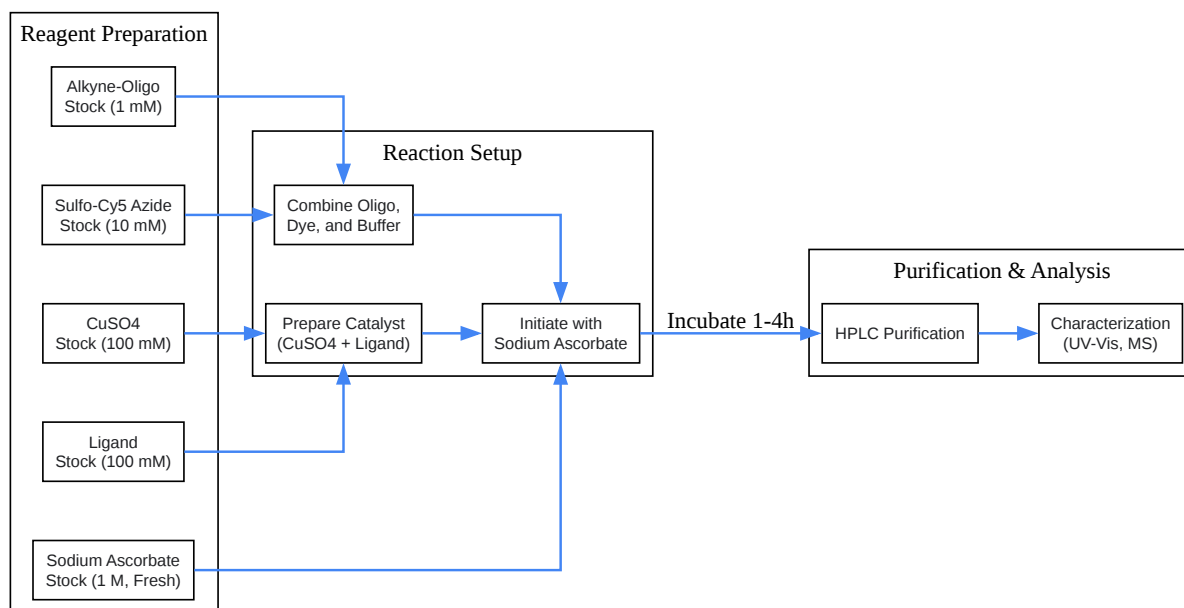

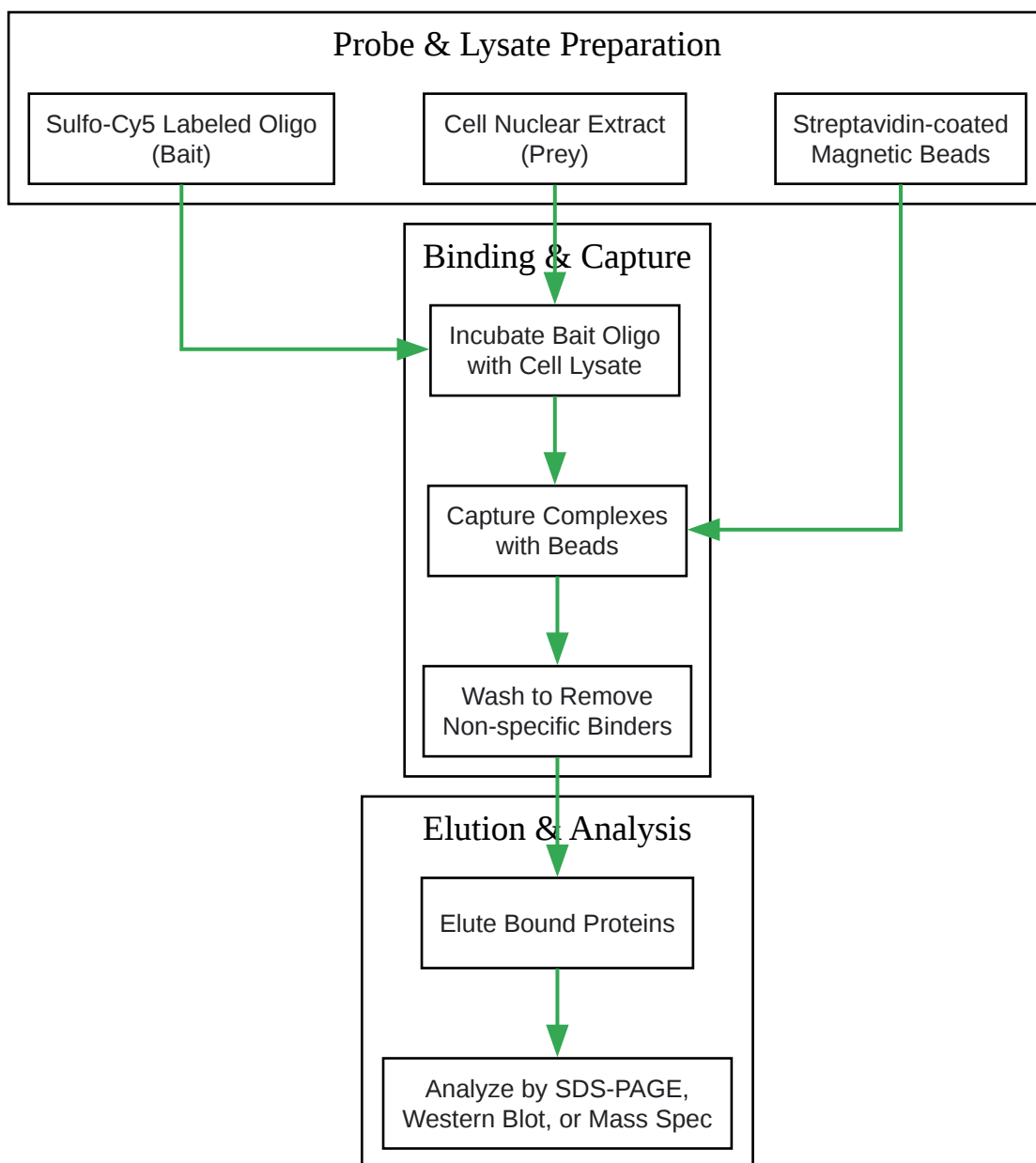

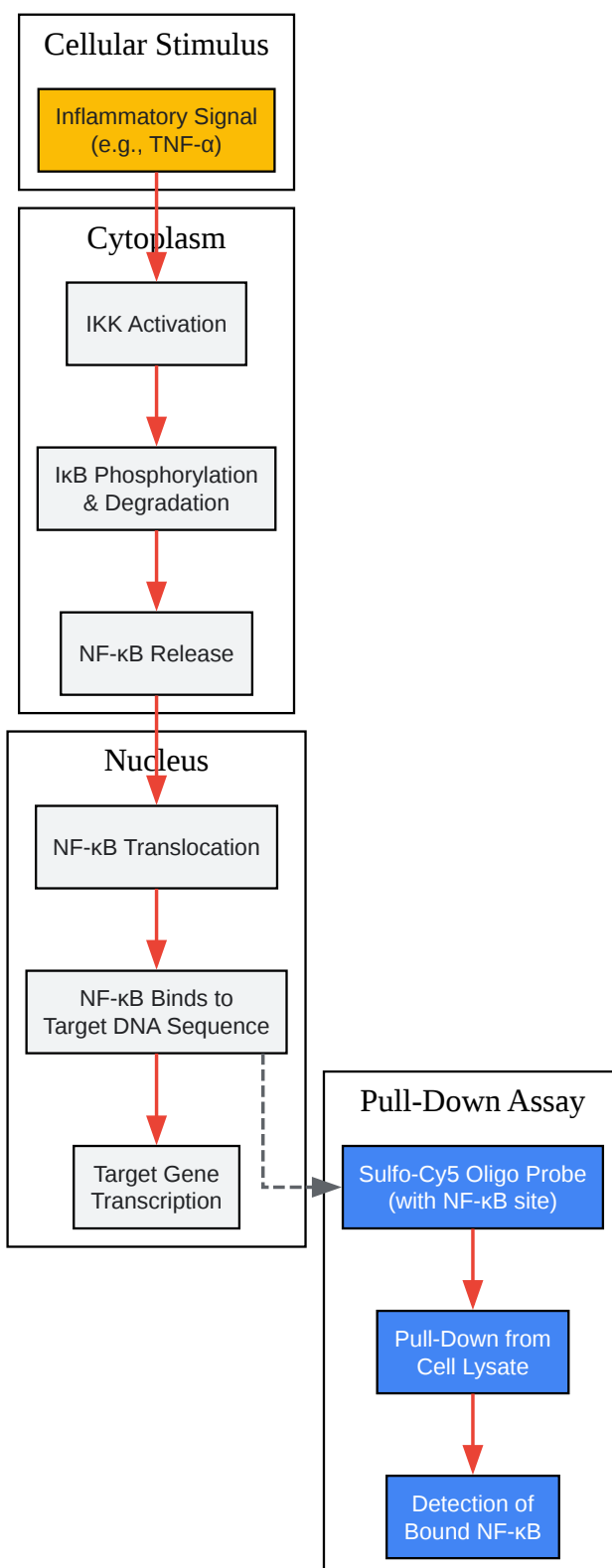

[Click to download full resolution via product page](#)

### Need Custom Synthesis?

BenchChem offers custom synthesis for rare earth carbides and specific isotopic labeling.

Email: [info@benchchem.com](mailto:info@benchchem.com) or [Request Quote Online](#).

## References

- 1. [scbt.com](http://scbt.com) [[scbt.com](http://scbt.com)]
- 2. Sulfo-Cy5 Azide, 1782950-80-4 | [BroadPharm](http://BroadPharm.com) [[BroadPharm](http://BroadPharm.com)]
- 3. Sulfo Cy5 Azide | [AxisPharm](http://AxisPharm.com) [[AxisPharm](http://AxisPharm.com)]
- To cite this document: BenchChem. [Labeling Oligonucleotides with Sulfo-Cy5 Azide: Application Notes and Protocols]. BenchChem, [2026]. [Online PDF]. Available at: [<https://www.benchchem.com/product/b15556027/docs#labeling-oligonucleotides-with-sulfo-cy5-azide-application-notes-and-protocols>]

### Disclaimer & Data Validity:

The information provided in this document is for Research Use Only (RUO) and is strictly not intended for diagnostic or therapeutic procedures. While BenchChem strives to provide accurate protocols, we make no warranties, express or implied, regarding the fitness of this product for every specific experimental setup.

**Technical Support:** The protocols provided are for reference purposes. Unsure if this reagent suits your experiment?

**Need Industrial/Bulk Grade?** [Request Custom Synthesis Quote](#)

## BenchChem

Our mission is to be the trusted global source of essential and advanced chemicals, empowering scientists and researchers to drive progress in science and industry.

### Contact

Address: 3281 E Guasti Rd  
Ontario, CA 91761, United States  
Phone: (601) 213-4426  
Email: [info@benchchem.com](mailto:info@benchchem.com)

Contact our Ph.D. Support Team for a compatibility check