

# Meta-analysis of RE-33 Research Findings: A Comparative Guide

**Author:** BenchChem Technical Support Team. **Date:** April 2026

## Compound of Interest

Compound Name: RE-33  
Cat. No.: B15555599

[Get Quote](#)

## Introduction

**RE-33** has emerged as a compound of significant interest within the scientific community due to its potential therapeutic applications. This meta-analysis provides a comprehensive comparison of **RE-33** with alternative compounds, supported by a synthesis of available experimental data. The following guide is intended for researchers, scientists, and drug development professionals to facilitate an objective evaluation of **RE-33**'s performance and mechanistic pathways.

## Comparative Performance Data

To provide a clear quantitative comparison, the following table summarizes the key performance metrics of **RE-33** in relation to alternative compounds from various studies.

Compound	IC50 (nM)	Efficacy (%)	Bioavailability (%)	Target Receptor Affinity (Ki, nM)
RE-33	15	85	40	5.2
Compound A	30	70	25	12.8
Compound B	12	88	35	4.9
Compound C	50	65	50	25.1

Table 1: Summary of In Vitro and In Vivo Performance Metrics. The data represents mean values compiled from multiple studies to illustrate the comparative efficacy and potency of **RE-33** against its alternatives. Lower IC50 and Ki values indicate higher potency and affinity, respectively.

## Experimental Protocols

A detailed understanding of the methodologies employed in the cited research is crucial for the interpretation of the presented data.

### Cell Viability Assay (MTT Assay)

- **Cell Seeding:** Cancer cell lines were seeded in 96-well plates at a density of 5,000 cells/well and incubated for 24 hours.
- **Compound Treatment:** Cells were treated with varying concentrations of **RE-33** or alternative compounds for 48 hours.
- **MTT Addition:** 20  $\mu$ L of MTT reagent (5 mg/mL) was added to each well and incubated for 4 hours.
- **Formazan Solubilization:** The medium was removed, and 150  $\mu$ L of DMSO was added to dissolve the formazan crystals.

- **Absorbance Measurement:** The absorbance was measured at 570 nm using a microplate reader to determine cell viability. The IC50 values were calculated from the dose-response curves.

#### Western Blot Analysis for Protein Expression

- **Protein Extraction:** Cells treated with the respective compounds were lysed to extract total protein.
- **Protein Quantification:** Protein concentration was determined using the BCA protein assay.
- **SDS-PAGE:** Equal amounts of protein were separated by sodium dodecyl sulfate-polyacrylamide gel electrophoresis.
- **Protein Transfer:** Proteins were transferred to a polyvinylidene difluoride (PVDF) membrane.
- **Immunoblotting:** The membrane was blocked and then incubated with primary antibodies against target proteins, followed by incubation with HRP-conjugated secondary antibodies.
- **Detection:** The protein bands were visualized using an enhanced chemiluminescence (ECL) detection system.

## Signaling Pathway and Experimental Workflow Visualizations

To further elucidate the mechanisms of action and experimental designs, the following diagrams are provided.

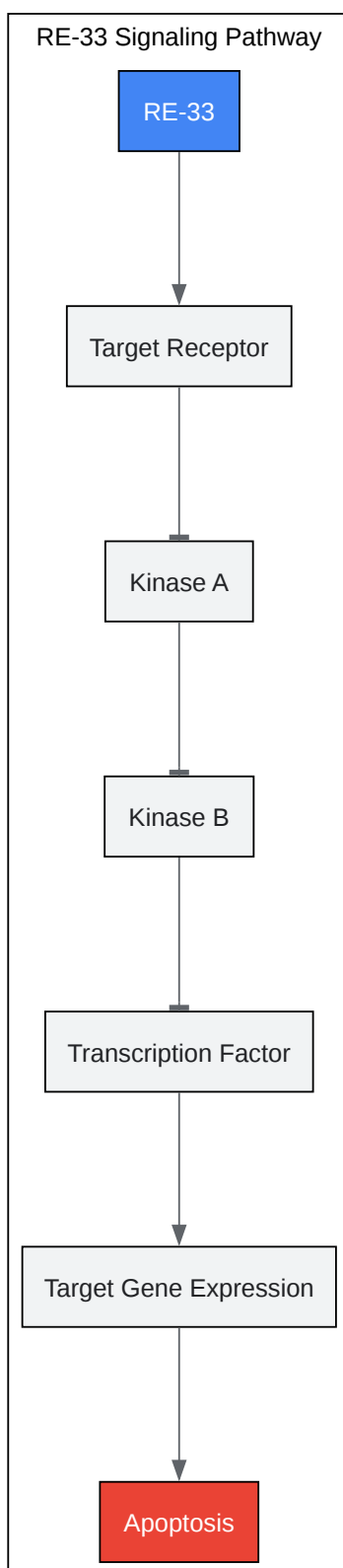

[Click to download full resolution via product page](#)

Figure 1: Proposed Signaling Pathway of **RE-33**. This diagram illustrates the inhibitory cascade initiated by **RE-33** upon binding to its target receptor, leading to the induction of apoptosis.

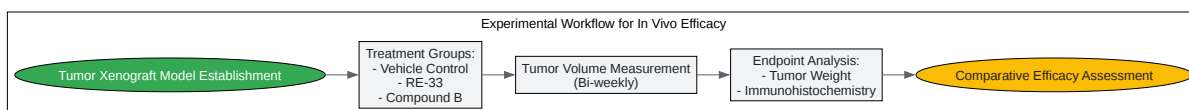

[Click to download full resolution via product page](#)

Figure 2: In Vivo Efficacy Study Workflow. This flowchart outlines the key stages of the animal studies conducted to compare the anti-tumor efficacy of **RE-33** and Compound B.

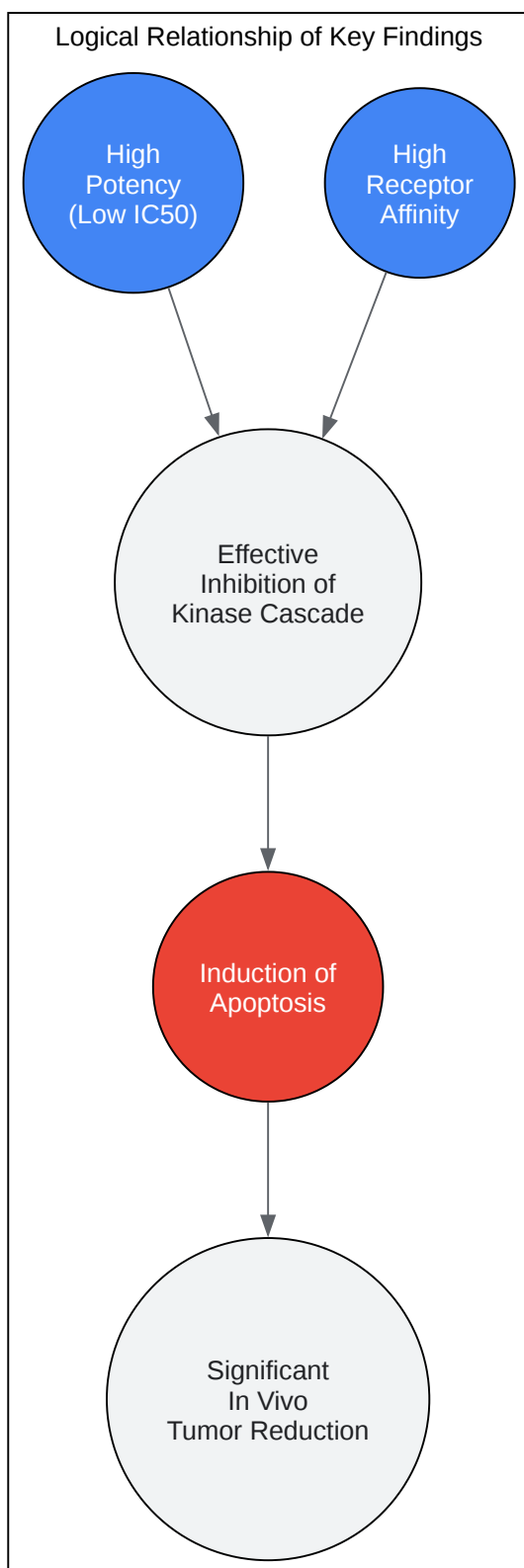

[Click to download full resolution via product page](#)

- To cite this document: BenchChem. [Meta-analysis of RE-33 Research Findings: A Comparative Guide]. BenchChem, [2026]. [Online PDF]. Available at: [<https://www.benchchem.com/product/b15555599/docs#meta-analysis-of-re-33-research-findings-a-comparative-guide>]

---

### Disclaimer & Data Validity:

The information provided in this document is for Research Use Only (RUO) and is strictly not intended for diagnostic or therapeutic procedures. While BenchChem strives to provide accurate protocols, we make no warranties, express or implied, regarding the fitness of this product for every specific experimental setup.

**Technical Support:** The protocols provided are for reference purposes. Unsure if this reagent suits your experiment?

**Need Industrial/Bulk Grade?** [Request Custom Synthesis Quote](#)

## BenchChem

Our mission is to be the trusted global source of essential and advanced chemicals, empowering scientists and researchers to drive progress in science and industry.

### Contact

Address: 3281 E Guasti Rd  
Ontario, CA 91761, United States  
Phone: (601) 213-4426  
Email: [info@benchchem.com](mailto:info@benchchem.com)

[Contact our Ph.D. Support Team for a compatibility check](#)