

Application Notes and Protocols: Sulfo-Cy7 Conjugation to Antibodies via Thiol Chemistry

Author: BenchChem Technical Support Team. **Date:** December 2025

Compound of Interest

Compound Name: Sulfo Cy7 bis-SH

Cat. No.: B15555176

[Get Quote](#)

For Researchers, Scientists, and Drug Development Professionals

Introduction

Fluorescent labeling of antibodies is a cornerstone technique in biological research and diagnostics, enabling the visualization and tracking of specific targets.[1] Near-infrared (NIR) dyes, such as Sulfo-Cyanine7 (Sulfo-Cy7), offer significant advantages for these applications, particularly for in vivo imaging.[2] The NIR spectrum (700-900 nm) is often called the "optical window" for biological tissues because it is characterized by minimal autofluorescence and light absorption, allowing for deeper tissue penetration and a higher signal-to-noise ratio.[2]

This document provides a detailed protocol for the conjugation of a thiol-reactive Sulfo-Cy7 dye to an antibody. The method is based on the selective reduction of the antibody's native interchain disulfide bonds to generate free sulfhydryl (-SH) groups, followed by their reaction with a maleimide-activated Sulfo-Cy7 dye.[3][4] This thiol-maleimide chemistry is highly efficient and allows for more site-specific labeling compared to amine-based conjugation, which targets lysine residues that may be present in the antigen-binding site.[4][5] The resulting Sulfo-Cy7 antibody conjugate is suitable for a wide range of applications, including flow cytometry, immunofluorescence, and non-invasive in vivo imaging.[6]

Data Presentation

Table 1: Spectroscopic Properties of Sulfo-Cy7

This table summarizes the key optical properties of the Sulfo-Cy7 fluorophore, which are essential for instrument setup and data analysis.

| Property | Value | Reference |
|---|---|-----------|
| Maximum Excitation Wavelength (λ_{ex}) | ~750 nm | [2][7] |
| Maximum Emission Wavelength (λ_{em}) | ~773 - 779 nm | [2][8] |
| Molar Extinction Coefficient (ϵ) at λ_{ex} | ~240,000 M ⁻¹ cm ⁻¹ | [8] |
| Fluorescence Quantum Yield (Φ) | ~0.24 - 0.3 | [2][8] |
| Recommended Excitation Laser | 750 nm | [7] |
| Recommended Emission Filter | 780 - 850 nm | [7] |

Table 2: Recommended Molar Ratios for Reduction and Conjugation

Optimal labeling requires careful control over the molar ratios of the reducing agent and the dye relative to the antibody. The ratios below are starting points and may require optimization depending on the specific antibody and desired Degree of Labeling (DOL).

| Step | Reagent | Molar Ratio (Reagent:Antibody) | Purpose |
|-------------|---------------------|-----------------------------------|---|
| Reduction | TCEP | 10:1 to 20:1 | To reduce interchain disulfide bonds, creating free thiols.[5] [9] |
| Conjugation | Sulfo-Cy7 Maleimide | 10:1 to 20:1 | To covalently attach the dye to the newly formed thiol groups.[9] |

Experimental Workflow and Signaling Pathways

The overall workflow for antibody conjugation involves three main stages: reduction of the antibody, reaction with the maleimide-activated dye, and purification of the final conjugate.

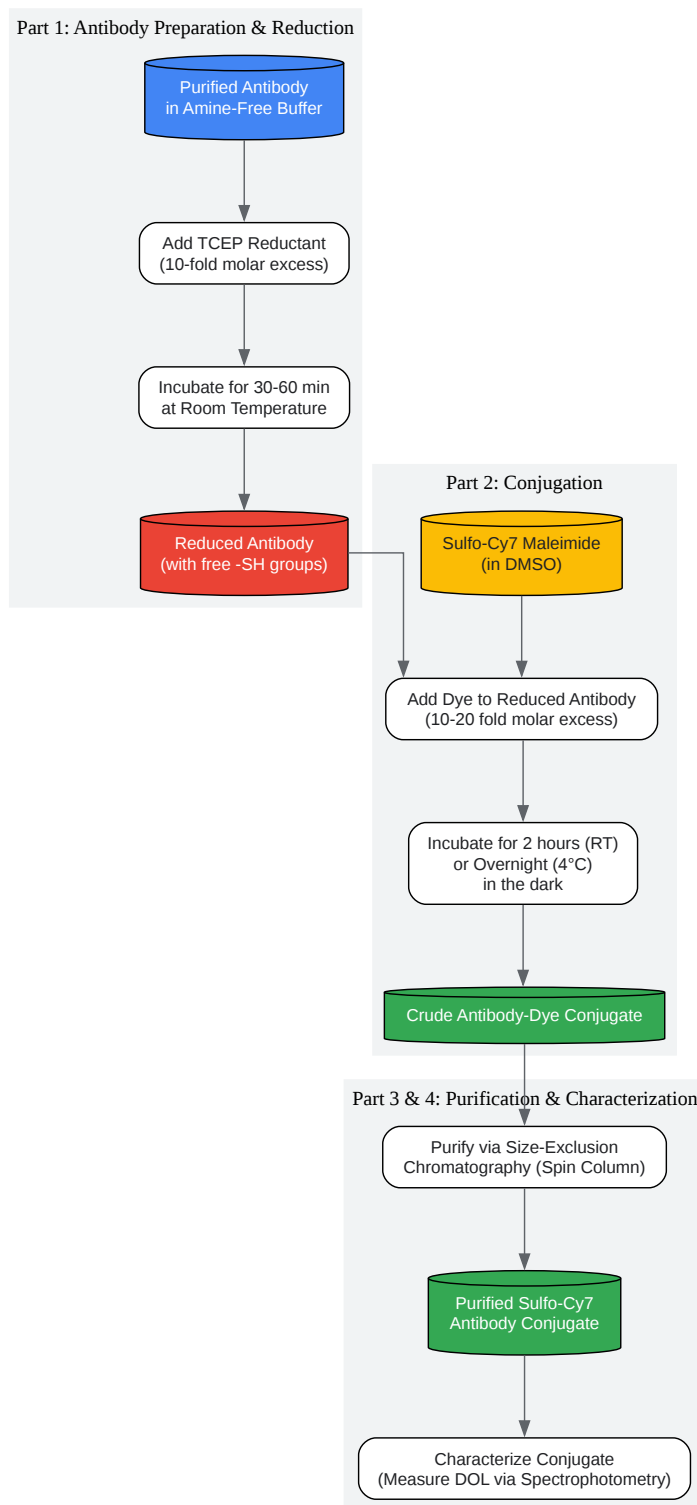

[Click to download full resolution via product page](#)

Caption: Experimental workflow for Sulfo-Cy7 conjugation.

The chemical basis of this protocol is the reaction between a thiol (sulfhydryl) group on the reduced antibody and the maleimide group on the dye. This forms a stable thioether bond.

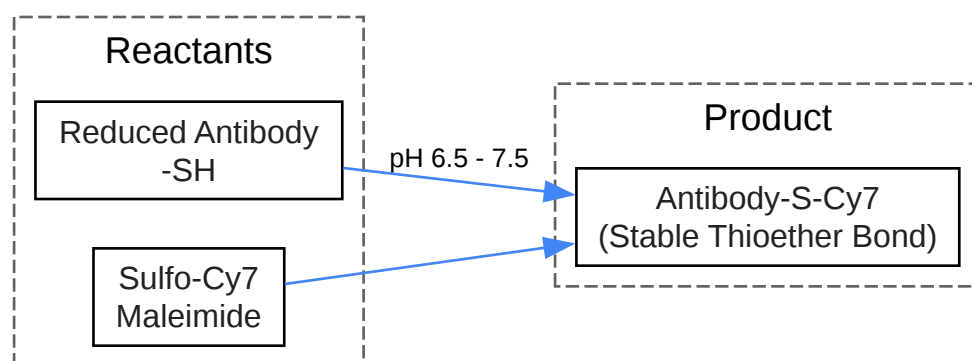

[Click to download full resolution via product page](#)

Caption: Thiol-Maleimide conjugation reaction chemistry.

Experimental Protocols

This protocol is designed for conjugating approximately 1 mg of an IgG antibody. Reactions can be scaled up or down as needed.

Materials and Reagents

- Purified antibody (IgG) at 2-10 mg/mL in an amine-free buffer (e.g., PBS, HEPES).[10]
- Tris(2-carboxyethyl)phosphine (TCEP) hydrochloride
- Sulfo-Cy7 Maleimide
- Anhydrous Dimethyl Sulfoxide (DMSO)
- Conjugation Buffer: 10-100 mM phosphate buffer (or HEPES, Tris) with 5 mM EDTA, pH 7.0-7.5.[5][9]
- Purification: Size-exclusion chromatography spin columns (e.g., Sephadex G-25) suitable for separating proteins from small molecules.[10]

- Spectrophotometer (UV-Vis)

Protocol Part 1: Antibody Reduction

This step uses TCEP to reduce the antibody's interchain disulfide bonds, exposing free thiol groups for conjugation.[3][11]

- Prepare Antibody: Start with a purified antibody solution at a concentration of 2-10 mg/mL. [10] If the buffer contains amines (like Tris or glycine), it must be exchanged for an amine-free buffer like PBS.[10]
- Prepare TCEP Stock Solution: Prepare a 10 mM TCEP stock solution in conjugation buffer.
- Initiate Reduction: Add a 10-fold molar excess of TCEP to the antibody solution. For a typical IgG (MW ~150,000 Da), this means adding approximately 0.67 μ L of 10 mM TCEP per 1 mg of antibody.
- Incubate: Gently mix and incubate the reaction for 30-60 minutes at room temperature.[5] To prevent the re-formation of disulfide bonds, it is advisable to perform this and the subsequent conjugation step under an inert gas like nitrogen or argon, though it is not strictly required.[5]

Protocol Part 2: Conjugation to Sulfo-Cy7 Maleimide

In this step, the maleimide-activated dye reacts with the free thiols on the reduced antibody.

- Prepare Dye Stock Solution: Immediately before use, allow the vial of Sulfo-Cy7 Maleimide to warm to room temperature. Prepare a 10 mM stock solution by dissolving the dye in anhydrous DMSO.[9] Vortex briefly to ensure it is fully dissolved.
- Add Dye to Antibody: Add a 10 to 20-fold molar excess of the dissolved Sulfo-Cy7 Maleimide to the reduced antibody solution while gently mixing.[9]
- Incubate: Protect the reaction mixture from light by wrapping the tube in aluminum foil. Incubate for 2 hours at room temperature or overnight at 4°C with gentle, continuous mixing. [9]

Protocol Part 3: Purification of the Conjugate

Purification is critical to remove unconjugated dye, which can cause high background signals in downstream applications.

- **Prepare Spin Column:** Prepare a size-exclusion spin column according to the manufacturer's instructions. This typically involves hydrating the resin and centrifuging to remove the storage buffer.
- **Apply Sample:** Carefully apply the entire conjugation reaction mixture to the center of the prepared column.
- **Elute Conjugate:** Centrifuge the column as per the manufacturer's protocol. The purified antibody-dye conjugate will be in the eluate, while the smaller, unconjugated dye molecules will be retained in the column resin.[\[10\]](#)
- **Store Conjugate:** Store the purified conjugate in a suitable buffer (e.g., PBS with 0.1% BSA and 0.02% sodium azide) at 4°C, protected from light.

Protocol Part 4: Characterization and Quality Control

The Degree of Labeling (DOL), or the average number of dye molecules per antibody, is a critical quality parameter.

- **Measure Absorbance:** Dilute a small amount of the purified conjugate in PBS. Measure the absorbance of the solution at 280 nm (A_{280}) and at the absorbance maximum for Sulfo-Cy7 (~750 nm, A_{750}).
- **Calculate DOL:** Use the following formula to calculate the DOL:
 - **Molar Concentration of Antibody:**
 - $\text{Corrected } A_{280} = A_{280} - (A_{750} \times CF_{280})$
 - $\text{Antibody Conc. (M)} = \text{Corrected } A_{280} / \epsilon_{\text{antibody}}$ (Where CF_{280} is the correction factor for the dye's absorbance at 280 nm, and $\epsilon_{\text{antibody}}$ is the molar extinction coefficient of the antibody at 280 nm, typically $\sim 210,000 \text{ M}^{-1}\text{cm}^{-1}$ for IgG).
 - **Molar Concentration of Dye:**

- Dye Conc. (M) = $A_{750} / \epsilon_{\text{dye}}$ (Where ϵ_{dye} is the molar extinction coefficient of Sulfo-Cy7 at ~750 nm, $\sim 240,000 \text{ M}^{-1}\text{cm}^{-1}$).
- Degree of Labeling (DOL):
 - $\text{DOL} = \text{Dye Conc. (M)} / \text{Antibody Conc. (M)}$

An optimal DOL for most antibodies is typically between 2 and 10.[10] Higher ratios can sometimes lead to reduced antibody function or fluorescence quenching.[12]

Applications of Sulfo-Cy7 Labeled Antibodies

Antibodies conjugated with Sulfo-Cy7 are powerful tools for a variety of sensitive detection methods:

- In Vivo Imaging: The NIR properties of Sulfo-Cy7 make it ideal for non-invasive imaging in living organisms, allowing for the tracking of drug distribution or monitoring tumor growth.[6]
- Flow Cytometry: As a far-red dye, Sulfo-Cy7 is excellent for multicolor flow cytometry panels, minimizing spectral overlap with fluorophores that emit in the blue, green, and orange channels.[13][14]
- Immunofluorescence and Microscopy: The dye's emission in the far-red spectrum helps reduce autofluorescence from cells and tissues, leading to clearer images with improved contrast.[2][7]

Need Custom Synthesis?

BenchChem offers custom synthesis for rare earth carbides and specific isotopic labeling.

Email: info@benchchem.com or [Request Quote Online](#).

References

- 1. bioconjugation.bocsci.com [bioconjugation.bocsci.com]
- 2. benchchem.com [benchchem.com]

- 3. Evaluation of Factors Influencing Antibody Reduction for Development of Antibody Drug Conjugates - PMC [pmc.ncbi.nlm.nih.gov]
- 4. bocsci.com [bocsci.com]
- 5. biotium.com [biotium.com]
- 6. Cy7: A Far-Red Fluorescent Dye for Precise Labeling [baseclick.eu]
- 7. benchchem.com [benchchem.com]
- 8. Sulfo-Cy7 bis-NHS ester | BroadPharm [broadpharm.com]
- 9. alfa-chemistry.com [alfa-chemistry.com]
- 10. Antibody Conjugation Protocol | AAT Bioquest [aatbio.com]
- 11. bocsci.com [bocsci.com]
- 12. Fluorescent labeled antibodies - balancing functionality and degree of labeling - PMC [pmc.ncbi.nlm.nih.gov]
- 13. APC-Cy7® Antibody Conjugates | Cell Signaling Technology [cellsignal.com]
- 14. Fluorescent Conjugated Antibodies: Protocol, Advantages, and Applications | Sino Biological [sinobiological.com]
- To cite this document: BenchChem. [Application Notes and Protocols: Sulfo-Cy7 Conjugation to Antibodies via Thiol Chemistry]. BenchChem, [2025]. [Online PDF]. Available at: [https://www.benchchem.com/product/b15555176#step-by-step-guide-for-sulfo-cy7-bis-sh-conjugation-to-antibodies]

Disclaimer & Data Validity:

The information provided in this document is for Research Use Only (RUO) and is strictly not intended for diagnostic or therapeutic procedures. While BenchChem strives to provide accurate protocols, we make no warranties, express or implied, regarding the fitness of this product for every specific experimental setup.

Technical Support: The protocols provided are for reference purposes. Unsure if this reagent suits your experiment? [[Contact our Ph.D. Support Team for a compatibility check](#)]

Need Industrial/Bulk Grade? [Request Custom Synthesis Quote](#)

BenchChem

Our mission is to be the trusted global source of essential and advanced chemicals, empowering scientists and researchers to drive progress in science and industry.

Contact

Address: 3281 E Guasti Rd

Ontario, CA 91761, United States

Phone: (601) 213-4426

Email: info@benchchem.com