

# An In-depth Technical Guide to AF 594 Azide for Advanced Bioconjugation

**Author:** BenchChem Technical Support Team. **Date:** April 2026

## Compound of Interest

Compound Name: AF 594 azide

Cat. No.: B15555211

[Get Quote](#)

For Researchers, Scientists, and Drug Development Professionals

## Introduction

**AF 594 azide** is a high-performance, red-fluorescent probe widely utilized in the life sciences for the specific labeling of biomolecules. As an azide-functionalized derivative of the Alexa Fluor 594 dye, it possesses exceptional photostability, high fluorescence quantum yield, and good water solubility.[1] Its fluorescence is not sensitive to pH variations between 4 and 10.[1] [2] These properties make it an ideal tool for demanding applications such as fluorescence microscopy, flow cytometry, and super-resolution microscopy.[1][3]

The core utility of **AF 594 azide** lies in its ability to participate in bioorthogonal "click chemistry" reactions. The azide group serves as a chemical handle that can be covalently and specifically linked to a biomolecule containing a complementary alkyne group. This reaction is highly selective and efficient, proceeding with minimal side reactions in complex biological samples.[4] [5] This guide provides a comprehensive overview of the technical properties, reaction mechanisms, and detailed protocols for the application of **AF 594 azide** in advanced bioconjugation.

## Core Properties and Technical Data

**AF 594 azide** is characterized by its robust photophysical and chemical properties, which are critical for generating high-quality fluorescence data. The dye's sulfonated rhodamine core structure contributes to its brightness and reduced tendency for self-quenching.

## Quantitative Data Summary

The key technical specifications for **AF 594 azide** and its parent fluorophore are summarized in the table below for easy reference and comparison.

Property	Value	Reference(s)
Excitation Maximum ( $\lambda_{ex}$ )	~590 nm	[3][4][6]
Emission Maximum ( $\lambda_{em}$ )	~617 nm	[3][4][6]
Molar Extinction Coeff. ( $\epsilon$ )	92,000 $\text{cm}^{-1}\text{M}^{-1}$	[4]
Fluorescence Quantum Yield ( $\Phi$ )	0.66	[1][4][6]
Molecular Formula	$\text{C}_{38}\text{H}_{39}\text{KN}_6\text{O}_{10}\text{S}_2$	[7]
Molecular Weight	842.98 g/mol	[7]
Solubility	Water, DMSO, DMF	[6]
Optimal pH Range	4 - 10	[1][2]

## Mechanism of Action: Bioorthogonal Click Chemistry

**AF 594 azide** is primarily employed in click chemistry, a class of reactions that are rapid, specific, and high-yield.[5] This allows for the precise covalent attachment of the fluorophore to a target molecule that has been metabolically, enzymatically, or chemically engineered to contain an alkyne group. Two main pathways are used: the copper(I)-catalyzed azide-alkyne cycloaddition (CuAAC) and the copper-free strain-promoted azide-alkyne cycloaddition (SPAAC).

## Copper(I)-Catalyzed Azide-Alkyne Cycloaddition (CuAAC)

The CuAAC reaction is the most common form of click chemistry, involving the reaction between a terminal alkyne and an azide to form a stable 1,2,3-triazole linkage.[8][9] The reaction is catalyzed by a Cu(I) species, which is typically generated in situ from a Cu(II) salt (e.g., CuSO<sub>4</sub>) and a reducing agent like sodium ascorbate.[10] To prevent oxidative damage to biomolecules and enhance reaction efficiency, a copper-chelating ligand such as THPTA (tris(3-hydroxypropyltriazolylmethyl)amine) is often included.[2][9]

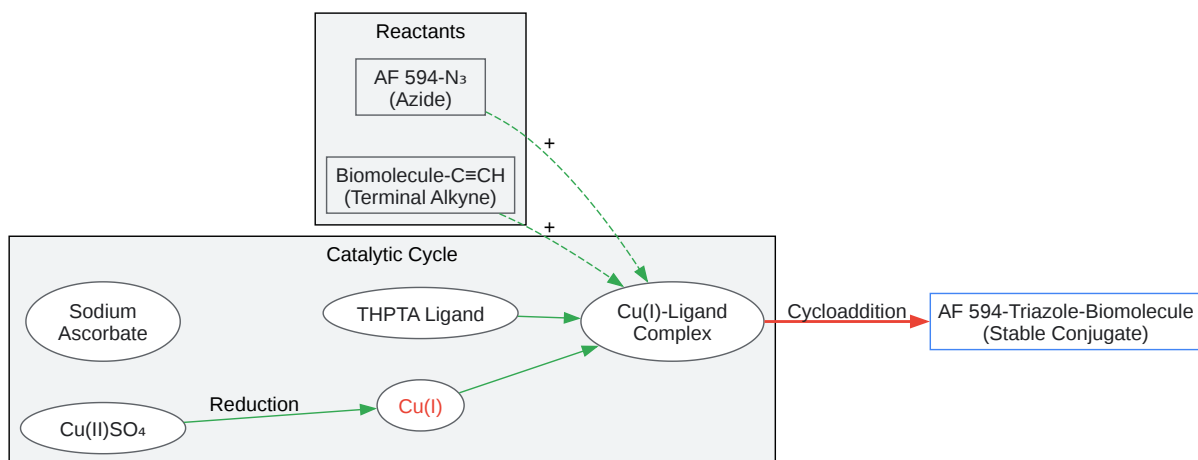

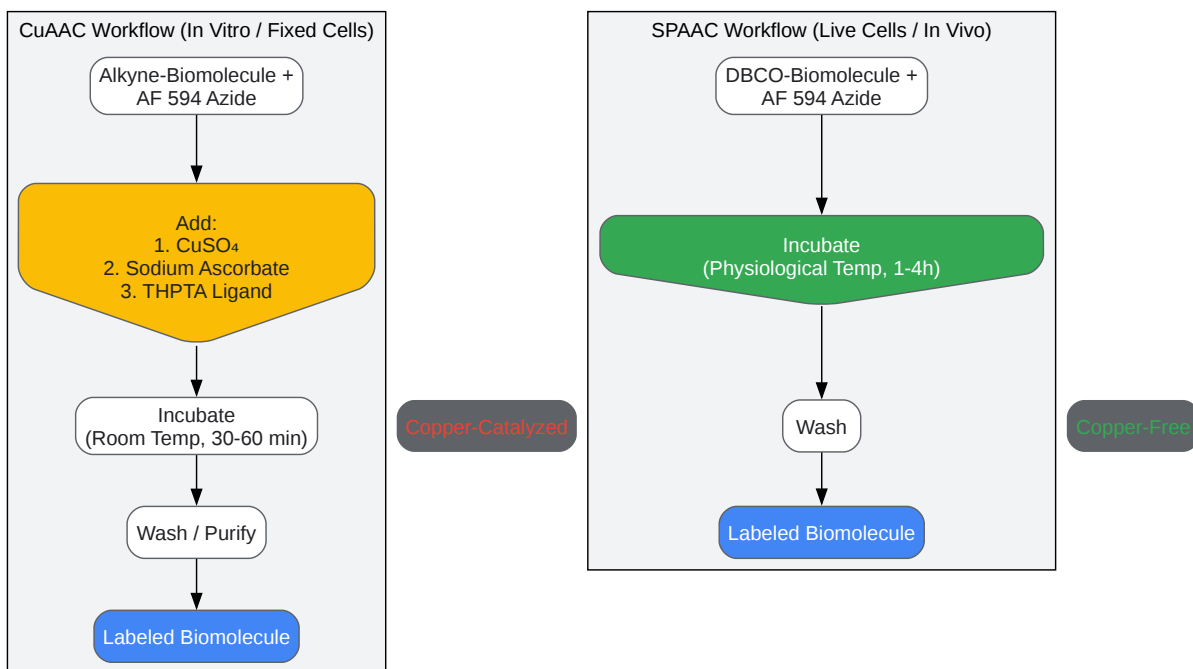

Comparison of Bioconjugation Workflows

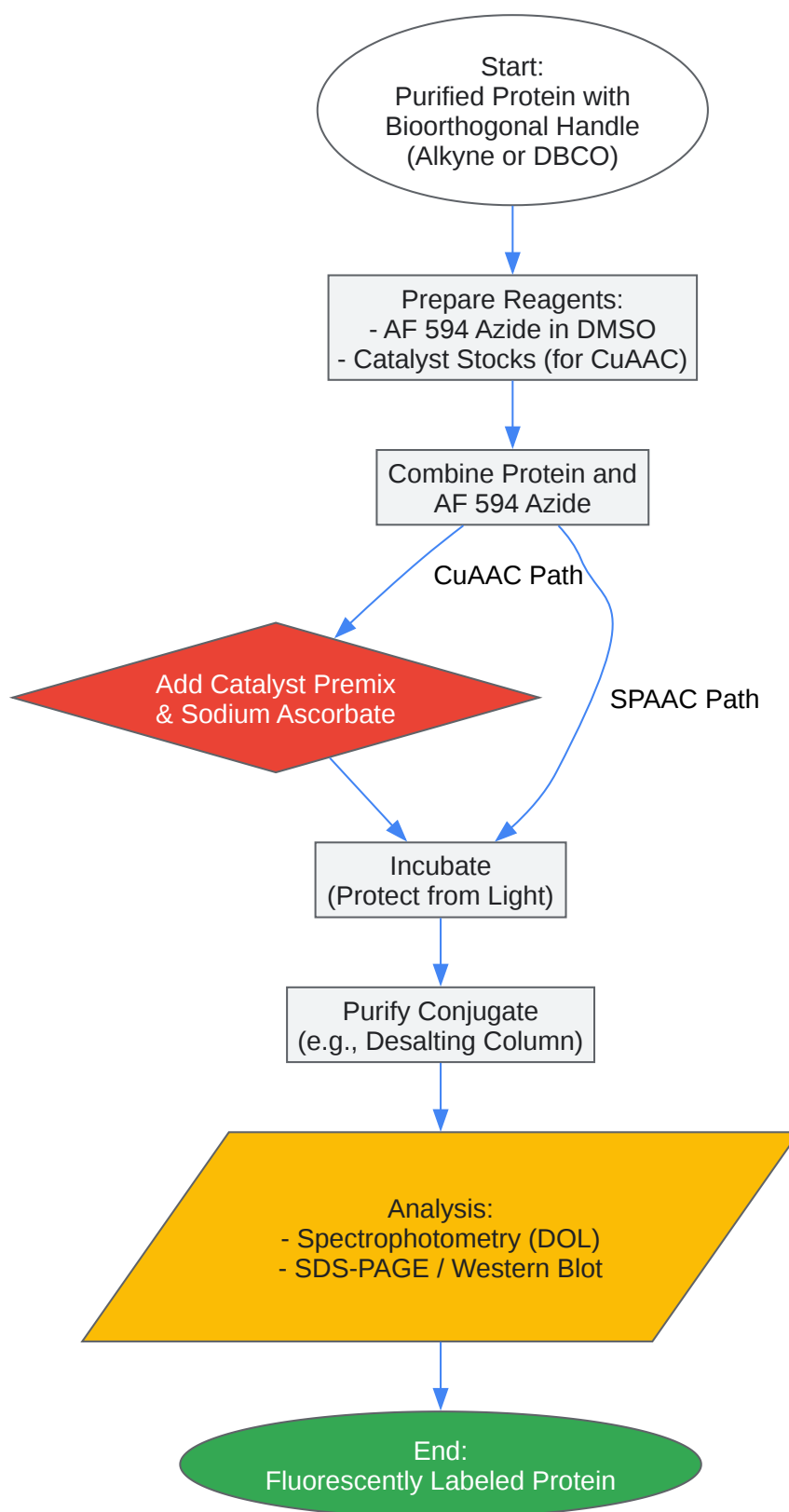

[Click to download full resolution via product page](#)

**Need Custom Synthesis?**

BenchChem offers custom synthesis for rare earth carbides and specific isotopic labeling.

Email: [info@benchchem.com](mailto:info@benchchem.com) or [Request Quote Online](#).

## References

- [1. Fluorescence quantum yields \(QY\) and lifetimes \( \$\tau\$ \) for Alexa Fluor dyes—Table 1.5 | Thermo Fisher Scientific - TW \[thermofisher.com\]](#)
- [2. Labeling Live Cells by Copper-Catalyzed Alkyne-Azide Click Chemistry - PMC \[pmc.ncbi.nlm.nih.gov\]](#)
- [3. FluoroFinder \[app.fluorofinder.com\]](#)
- [4. Alexa Fluor - Wikipedia \[en.wikipedia.org\]](#)
- [5. broadpharm.com \[broadpharm.com\]](#)
- [6. Alexa Fluor 594® Secondary Antibodies - Jackson Immuno \[jacksonimmuno.com\]](#)
- [7. Modification of Protein Scaffolds via Copper-Catalyzed Azide–Alkyne Cycloaddition | Springer Nature Experiments \[experiments.springernature.com\]](#)
- [8. interchim.fr \[interchim.fr\]](#)
- [9. Copper\(I\)-Catalyzed Alkyne-Azide Cycloaddition - Creative Biolabs \[creative-biolabs.com\]](#)
- [10. jenabioscience.com \[jenabioscience.com\]](#)
- To cite this document: BenchChem. [An In-depth Technical Guide to AF 594 Azide for Advanced Bioconjugation]. BenchChem, [2026]. [Online PDF]. Available at: [<https://www.benchchem.com/product/b15555211/docs#an-in-depth-technical-guide-to-af-594-azide-for-advanced-bioconjugation>]

---

### Disclaimer & Data Validity:

The information provided in this document is for Research Use Only (RUO) and is strictly not intended for diagnostic or therapeutic procedures. While BenchChem strives to provide accurate protocols, we make no warranties, express or implied, regarding the fitness of this product for every specific experimental setup.

**Technical Support:** The protocols provided are for reference purposes. Unsure if this reagent suits your experiment?

**Need Industrial/Bulk Grade?** [Request Custom Synthesis Quote](#)

## BenchChem

Our mission is to be the trusted global source of essential and advanced chemicals, empowering scientists and researchers to drive progress in science and industry.

### Contact

Address: 3281 E Guasti Rd  
Ontario, CA 91761, United States  
Phone: (601) 213-4426  
Email: [info@benchchem.com](mailto:info@benchchem.com)

[Contact our Ph.D. Support Team for a compatibility check](#)