

# AF 594 azide compatibility with different buffers

**Author:** BenchChem Technical Support Team. **Date:** April 2026

## Compound of Interest

Compound Name: AF 594 azide

Cat. No.: B15555211

[Get Quote](#)

## AF 594 Azide Technical Support Center

This technical support center provides researchers, scientists, and drug development professionals with comprehensive guidance on the use of **AF 594 azide** in various applications. Here you will find answers to frequently asked questions, detailed troubleshooting guides, and optimized experimental protocols to ensure the success of your experiments.

## Frequently Asked Questions (FAQs)

Q1: What is **AF 594 azide** and what is it used for?

**AF 594 azide** is a bright, photostable, red-fluorescent dye functionalized with an azide group. [1][2] It is primarily used for labeling and detecting alkyne-containing biomolecules via copper-catalyzed azide-alkyne cycloaddition (CuAAC) or strain-promoted azide-alkyne cycloaddition (SPAAC), commonly known as "click chemistry." [3][4] These reactions are highly efficient and specific, making **AF 594 azide** a valuable tool in various applications, including fluorescence microscopy, flow cytometry, and super-resolution microscopy. [1][2]

Q2: What are the key photophysical properties of AF 594?

AF 594 exhibits excellent photophysical properties, making it a robust choice for fluorescence-based assays. Key quantitative data are summarized in the table below.

Property	Value
Excitation Maximum (Ex)	590 nm
Emission Maximum (Em)	617 nm
Molar Extinction Coefficient ( $\epsilon$ )	73,000 $\text{cm}^{-1}\text{M}^{-1}$
Fluorescence Quantum Yield ( $\Phi$ )	0.66

Data sourced from various supplier specifications and publications.[1][5]

Q3: Is the fluorescence of AF 594 sensitive to pH?

The fluorescence of AF 594 is largely insensitive to pH in the range of 4 to 10, which makes it suitable for a wide variety of biological experiments conducted under physiological conditions. [6][7]

Q4: How should I store and handle **AF 594 azide**?

For long-term storage, **AF 594 azide** should be stored at  $-20^{\circ}\text{C}$ , protected from light and moisture.[8] Before use, allow the vial to warm to room temperature before opening to prevent condensation. For preparing stock solutions, anhydrous dimethylsulfoxide (DMSO) or dimethylformamide (DMF) are commonly used. Once dissolved, it is recommended to use the solution promptly or aliquot and store at  $-20^{\circ}\text{C}$  for short-term storage.

## Buffer Compatibility Guide

The choice of buffer is critical for the success of labeling experiments with **AF 594 azide**. The compatibility of a buffer depends on the type of click chemistry reaction being performed.

## Copper-Catalyzed Azide-Alkyne Cycloaddition (CuAAC)

For CuAAC reactions, it is crucial to use a buffer that does not interfere with the copper (I) catalyst.

Recommended Buffers:

- Phosphate-Buffered Saline (PBS): A commonly used buffer that is generally compatible with CuAAC.
- HEPES, MOPS, Acetate buffers: These buffers are also suitable for CuAAC reactions.[9]

#### Buffers to Avoid:

- Tris-based buffers (e.g., Tris-HCl): Tris can chelate copper ions, which inhibits the catalytic activity required for the click reaction.[9][10] If your biomolecule is in a Tris buffer, it is recommended to perform a buffer exchange to a compatible buffer like PBS before starting the reaction.

#### Buffer Additives:

- Reducing Agents: A reducing agent, such as sodium ascorbate, is essential to maintain copper in its active Cu(I) oxidation state.[9] A fresh solution should be prepared for each experiment.
- Copper Ligands: Ligands like THPTA (Tris(3-hydroxypropyltriazolylmethyl)amine) are highly recommended to stabilize the Cu(I) catalyst and increase reaction efficiency.[11][12]
- Primary Amines: Buffers containing primary amines (e.g., glycine) should be avoided as they can react with some reactive dyes, although this is less of a concern for azide-alkyne reactions.[8]

## Strain-Promoted Azide-Alkyne Cycloaddition (SPAAC)

SPAAC reactions are copper-free and therefore compatible with a broader range of buffers.

#### Recommended Buffers:

- PBS, HEPES, Tris-based buffers: These are all generally compatible with SPAAC reactions. [13] The choice of buffer can be optimized based on the requirements of the biomolecule being labeled.

#### Considerations for SPAAC:

- Organic Co-solvents: The rate of SPAAC reactions can be influenced by the presence of organic co-solvents.<sup>[14]</sup> It is advisable to minimize the concentration of organic solvents if possible, or to empirically test their effect on your specific reaction.

## Troubleshooting Guide

This guide addresses common issues encountered during labeling experiments with **AF 594 azide**.

Issue	Possible Cause	Recommended Solution
<p>Low or No Fluorescence Signal</p>	<p>Inefficient Labeling Reaction:- Inactive copper catalyst (CuAAC).- Incompatible buffer (e.g., Tris for CuAAC).- Degraded AF 594 azide.</p>	<p>- Use a fresh solution of sodium ascorbate.- Ensure the use of a copper-chelating ligand like THPTA.- Perform a buffer exchange to a compatible buffer (e.g., PBS).- Use a fresh vial of AF 594 azide.</p>
<p>Low Concentration of Analyte:- Insufficient amount of alkyne-modified biomolecule.</p>	<p>- Increase the concentration of the biomolecule if possible.- Optimize the stoichiometry of the reactants.</p>	
<p>High Background Fluorescence</p>	<p>Non-specific Binding:- Excess AF 594 azide not removed after the reaction.</p>	<p>- Ensure thorough purification of the labeled product (e.g., via dialysis, size-exclusion chromatography, or precipitation).- Include adequate washing steps in your protocol.</p>
<p>Autofluorescence:- Intrinsic fluorescence from cells or tissues.</p>	<p>- Include an unstained control to assess the level of autofluorescence.- Consider using a quenching agent if autofluorescence is problematic.</p>	
<p>Precipitation in Reaction Mixture</p>	<p>Solubility Issues:- AF 594 azide or the biomolecule is not fully dissolved.- Formation of insoluble copper complexes (CuAAC).</p>	<p>- Ensure all components are fully dissolved before mixing.- Pre-mix the copper sulfate and ligand before adding to the reaction mixture to prevent precipitation in phosphate buffers.[9]</p>

## Troubleshooting Workflow

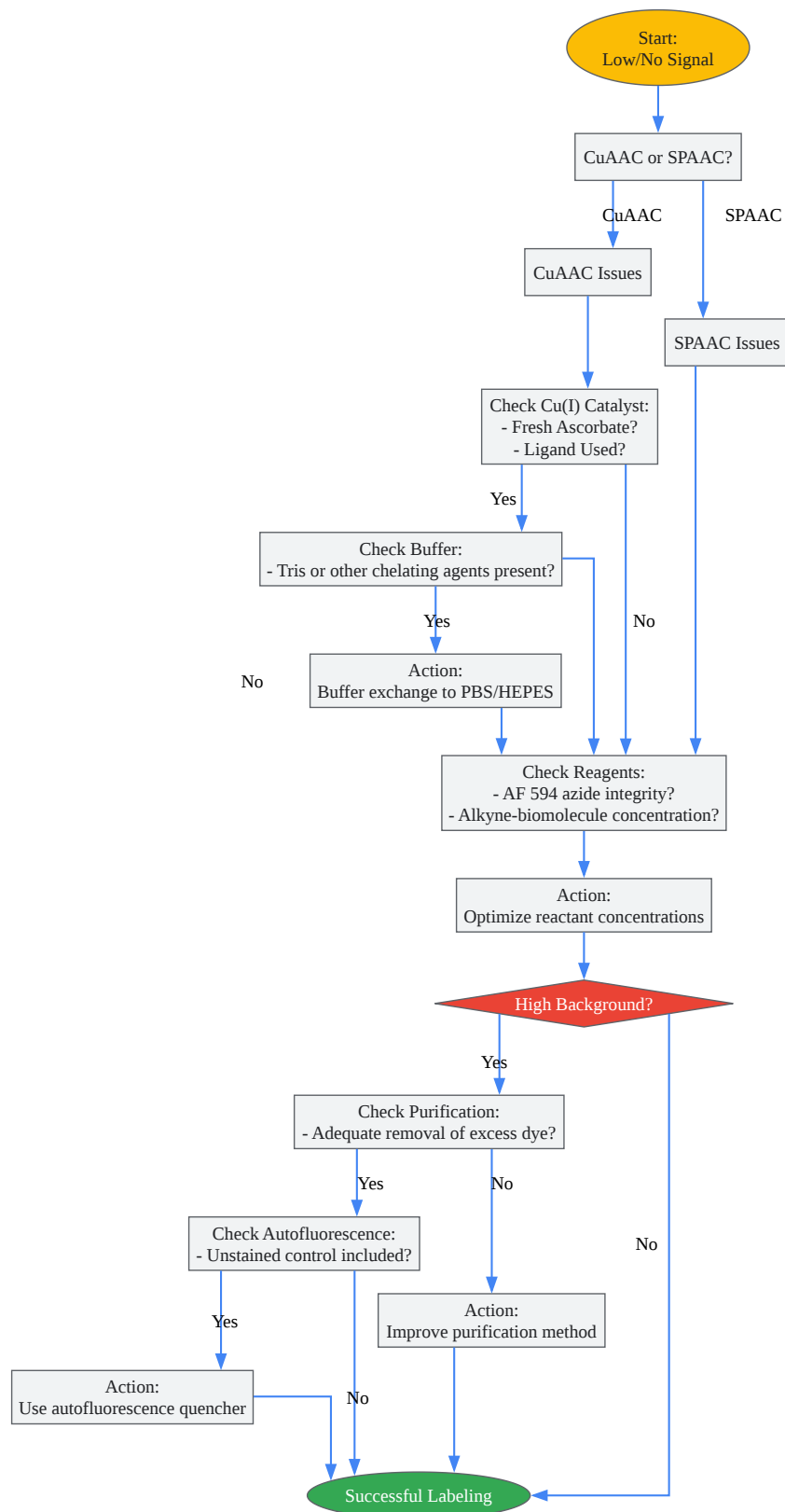

[Click to download full resolution via product page](#)

A troubleshooting decision tree for **AF 594 azide** labeling experiments.

## Experimental Protocols

### Protocol 1: Copper-Catalyzed Azide-Alkyne Cycloaddition (CuAAC) of a Protein

This protocol provides a general guideline for labeling an alkyne-modified protein with **AF 594 azide**.

Materials:

- Alkyne-modified protein in PBS (pH 7.4)
- **AF 594 azide**
- Anhydrous DMSO
- Copper(II) sulfate ( $\text{CuSO}_4$ )
- THPTA ligand
- Sodium Ascorbate
- Deionized water
- Purification column (e.g., size-exclusion)

Procedure:

- Prepare Stock Solutions:
  - Dissolve **AF 594 azide** in anhydrous DMSO to a concentration of 10 mM.
  - Prepare a 20 mM solution of  $\text{CuSO}_4$  in deionized water.
  - Prepare a 50 mM solution of THPTA in deionized water.

- Prepare a 100 mM solution of sodium ascorbate in deionized water. This solution should be prepared fresh.
- Reaction Setup:
  - In a microcentrifuge tube, add the alkyne-modified protein to a final concentration of 1-5 mg/mL in PBS.
  - Add the **AF 594 azide** stock solution to a final concentration that is in 2-5 fold molar excess to the protein.
  - In a separate tube, pre-mix the CuSO<sub>4</sub> and THPTA solutions. For a final copper concentration of 0.1 mM, use a 5-fold excess of ligand (0.5 mM final concentration).[\[15\]](#)
  - Add the copper/ligand mixture to the protein/azide solution.
  - Initiate the reaction by adding the freshly prepared sodium ascorbate solution to a final concentration of 1-5 mM.
- Incubation:
  - Incubate the reaction mixture for 1-2 hours at room temperature, protected from light.
- Purification:
  - Remove the unreacted **AF 594 azide** and other small molecules by passing the reaction mixture through a size-exclusion purification column pre-equilibrated with PBS.
  - Collect the fractions containing the labeled protein.
- Characterization:
  - Determine the degree of labeling by measuring the absorbance of the purified conjugate at 280 nm (for the protein) and 590 nm (for AF 594).

## Protocol 2: Strain-Promoted Azide-Alkyne Cycloaddition (SPAAC) of a Protein

This protocol is for labeling a protein modified with a strained alkyne (e.g., DBCO) with **AF 594 azide**.

Materials:

- Strained alkyne-modified protein in a suitable buffer (e.g., PBS or Tris, pH 7.4)
- **AF 594 azide**
- Anhydrous DMSO
- Purification column (e.g., size-exclusion)

Procedure:

- Prepare Stock Solution:
  - Dissolve **AF 594 azide** in anhydrous DMSO to a concentration of 10 mM.
- Reaction Setup:
  - In a microcentrifuge tube, add the strained alkyne-modified protein to a final concentration of 1-5 mg/mL.
  - Add the **AF 594 azide** stock solution to a final concentration that is in 2-5 fold molar excess to the protein.
- Incubation:
  - Incubate the reaction mixture for 4-12 hours at room temperature or overnight at 4°C, protected from light. Reaction times may need to be optimized depending on the specific strained alkyne used.
- Purification:
  - Purify the labeled protein using a size-exclusion purification column as described in the CuAAC protocol.

- Characterization:
  - Characterize the degree of labeling as described in the CuAAC protocol.

## Signaling Pathways and Workflows

### Experimental Workflow for CuAAC Labeling

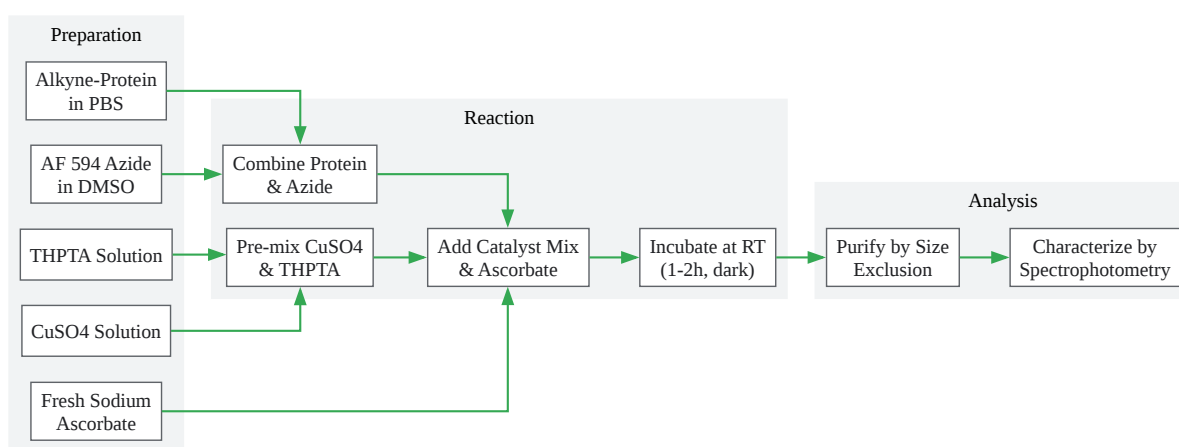

[Click to download full resolution via product page](#)

A generalized workflow for protein labeling using CuAAC with **AF 594 azide**.

## Logical Relationship of Buffer Components in CuAAC

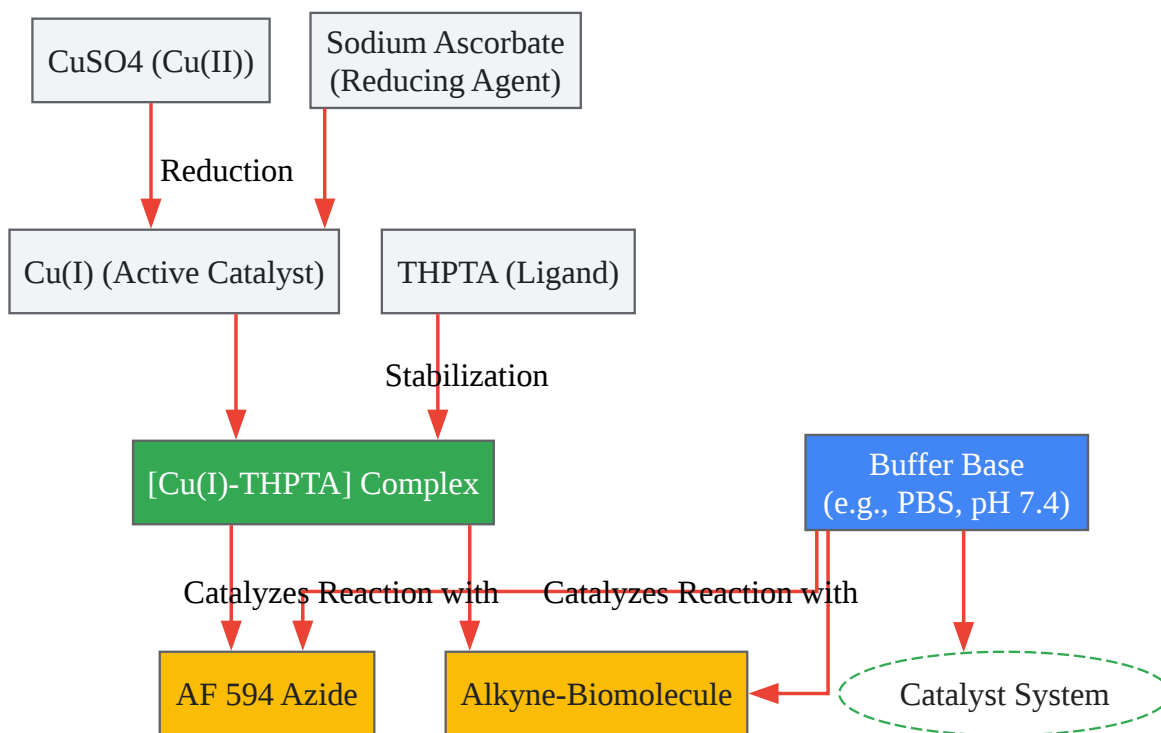

[Click to download full resolution via product page](#)

Interactions of buffer components in a typical CuAAC reaction.

### Need Custom Synthesis?

BenchChem offers custom synthesis for rare earth carbides and specific isotopic labeling.

Email: [info@benchchem.com](mailto:info@benchchem.com) or [Request Quote Online](#).

## References

- 1. FluoroFinder [[app.fluorofinder.com](http://app.fluorofinder.com)]
- 2. Alexa Fluor 594 Dye | Thermo Fisher Scientific - US [[thermofisher.com](http://thermofisher.com)]
- 3. bioconjugation.bocsci.com [[bioconjugation.bocsci.com](http://bioconjugation.bocsci.com)]
- 4. labinsights.nl [[labinsights.nl](http://labinsights.nl)]
- 5. Spectrum [Alexa Fluor 594] | AAT Bioquest [[aatbio.com](http://aatbio.com)]

- [6. cancer.iu.edu](http://cancer.iu.edu) [[cancer.iu.edu](http://cancer.iu.edu)]
- [7. Alexa Fluor Dyes Spanning the Visible and Infrared Spectrum—Section 1.3 | Thermo Fisher Scientific - TW](#) [[thermofisher.com](http://thermofisher.com)]
- [8. tools.thermofisher.com](http://tools.thermofisher.com) [[tools.thermofisher.com](http://tools.thermofisher.com)]
- [9. jenabioscience.com](http://jenabioscience.com) [[jenabioscience.com](http://jenabioscience.com)]
- [10. Analysis and Optimization of Copper-Catalyzed Azide–Alkyne Cycloaddition for Bioconjugation - PMC](#) [[pmc.ncbi.nlm.nih.gov](http://pmc.ncbi.nlm.nih.gov)]
- [11. benchchem.com](http://benchchem.com) [[benchchem.com](http://benchchem.com)]
- [12. vectorlabs.com](http://vectorlabs.com) [[vectorlabs.com](http://vectorlabs.com)]
- [13. Strain-promoted “click” chemistry for terminal labeling of DNA - PMC](#) [[pmc.ncbi.nlm.nih.gov](http://pmc.ncbi.nlm.nih.gov)]
- [14. pubs.acs.org](http://pubs.acs.org) [[pubs.acs.org](http://pubs.acs.org)]
- [15. researchgate.net](http://researchgate.net) [[researchgate.net](http://researchgate.net)]
- To cite this document: BenchChem. [AF 594 azide compatibility with different buffers]. BenchChem, [2026]. [Online PDF]. Available at: [<https://www.benchchem.com/product/b15555211/docs#af-594-azide-compatibility-with-different-buffers>]

---

### Disclaimer & Data Validity:

The information provided in this document is for Research Use Only (RUO) and is strictly not intended for diagnostic or therapeutic procedures. While BenchChem strives to provide accurate protocols, we make no warranties, express or implied, regarding the fitness of this product for every specific experimental setup.

**Technical Support:** The protocols provided are for reference purposes. Unsure if this reagent suits your experiment?

**Need Industrial/Bulk Grade?** [Request Custom Synthesis Quote](#)

# BenchChem

Our mission is to be the trusted global source of essential and advanced chemicals, empowering scientists and researchers to drive progress in science and industry.

## Contact

Address: 3281 E Guasti Rd

Ontario, CA 91761, United States

Phone: (601) 213-4426

Email: [info@benchchem.com](mailto:info@benchchem.com)

[Contact our Ph.D. Support Team for a compatibility check](#)