

# Validating the Neuroprotective Effects of Nimodipine in Primate Models: A Comparative Guide

**Author:** BenchChem Technical Support Team. **Date:** April 2026

## Compound of Interest

Compound Name: *Nimolinone*

Cat. No.: *B15554646*

[Get Quote](#)

For Researchers, Scientists, and Drug Development Professionals

This guide provides an objective comparison of the neuroprotective effects of Nimodipine in primate models of neurological injury, primarily focusing on cerebral ischemia and subarachnoid hemorrhage. It aims to equip researchers with the necessary data and methodologies to evaluate its efficacy against other potential neuroprotective agents.

## Nimodipine: Mechanism of Neuroprotection

Nimodipine, a dihydropyridine calcium channel blocker, is thought to exert its neuroprotective effects through a multi-faceted mechanism. Primarily, it blocks the L-type voltage-gated calcium channels, which are abundant in cerebral blood vessels. This action leads to vasodilation, improving cerebral blood flow and counteracting the vasospasm that often follows a subarachnoid hemorrhage.[1] Beyond its vasodilatory properties, Nimodipine is believed to have a direct neuroprotective role by preventing the influx of calcium into neurons during ischemic events.[1][2] This reduction in intracellular calcium overload helps to mitigate the downstream cascade of neurotoxic events, including apoptosis and neuronal death.

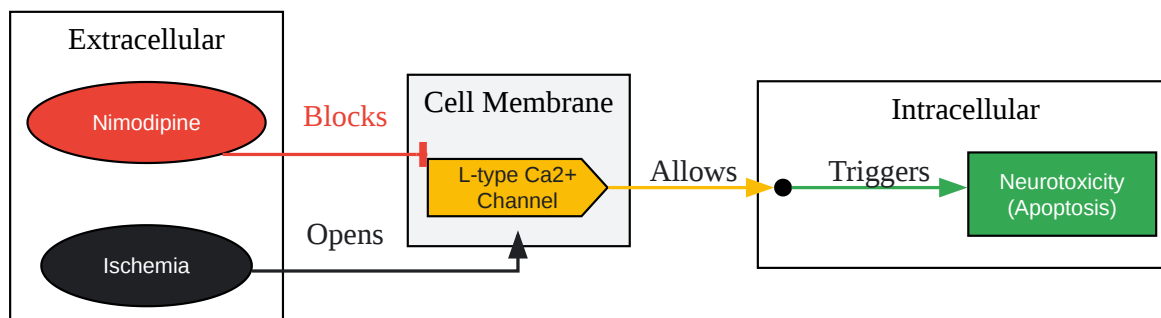

[Click to download full resolution via product page](#)

Caption: Nimodipine's primary mechanism of action.

## Comparative Efficacy of Nimodipine in Primate Models

Primate models of stroke and subarachnoid hemorrhage are crucial for preclinical validation due to their anatomical and physiological similarities to humans.[3][4] Studies in baboons and cynomolgus monkeys have been instrumental in evaluating the neuroprotective potential of Nimodipine.

### Nimodipine in Focal Cerebral Ischemia (Baboon Model)

A study investigating the effects of intravenous Nimodipine in a baboon model of focal cerebral ischemia, induced by temporary occlusion of the middle cerebral artery (MCAO), demonstrated a trend towards smaller areas of infarction in the treated group, although this difference was not statistically significant.[5] However, the neurological outcomes were significantly improved in the Nimodipine-treated animals at both 7 and 14 days post-stroke.[5]

Treatment Group	Neurological Score (Day 7)	Neurological Score (Day 14)	Infarct Volume
Nimodipine	Significantly better (p ≤ 0.01)	Significantly better (p ≤ 0.05)	Trend towards smaller volume (not statistically significant)
Control	-	-	-

Table 1: Efficacy of Intravenous Nimodipine in a Baboon Model of Focal Cerebral Ischemia.[5]

## Nimodipine in Subarachnoid Hemorrhage (Cynomolgus Monkey Model)

In a placebo-controlled trial using a cynomolgus monkey model of subarachnoid hemorrhage (SAH), oral Nimodipine was evaluated for its ability to prevent chronic cerebral vasospasm.[6] The study found no significant difference in the incidence or severity of vasospasm between the Nimodipine-treated and placebo groups.[6] Pathological examination revealed that while Nimodipine did not prevent vasospasm-related abnormalities, the severity of these changes was considered slightly less in the treated group.[7] Another study in baboons with experimentally induced SAH suggested that Nimodipine has a protective effect at a cellular level against the ionic changes associated with ischemia.[8]

Treatment Group	Incidence of Vasospasm	Severity of Vasospasm	Pathological Changes
Nimodipine (3, 6, or 12 mg/kg)	No significant difference	No significant difference	Slightly less severe
Placebo	-	-	-

Table 2: Efficacy of Oral Nimodipine in a Cynomolgus Monkey Model of Subarachnoid Hemorrhage.[6][7]

## Comparison with Alternative Neuroprotective Agents

While direct comparative studies of Nimodipine against other neuroprotective agents in the same primate model are scarce, several alternatives have been investigated independently.

Nicardipine, Cilostazol, and Clazosentan have been identified as potential alternatives to Nimodipine, with some studies suggesting they have more favorable pharmacokinetic profiles. [9][10] However, the number of preclinical trials in primates for these alternatives is significantly lower than for Nimodipine.[9]

- **Cilostazol:** A meta-analysis of animal studies (not limited to primates) has shown that cilostazol can significantly reduce infarct volume and improve neurofunctional deficits in cerebral ischemia models.[11] In a rat model of SAH, cilostazol was shown to attenuate cerebral vasospasm.[12]
- **Clazosentan:** This endothelin receptor antagonist has been investigated in clinical trials for preventing vasospasm after SAH, with some studies showing a reduction in vasospasm-related morbidity and mortality, though others have not found a significant effect on functional outcome.[13][14][15] Data from primate-specific studies are limited.

Due to the lack of head-to-head comparative data in primate models, a direct quantitative comparison of efficacy is not currently possible. The available data suggests that while Nimodipine shows some promise in improving neurological outcomes after ischemic stroke in primates, its efficacy in preventing vasospasm following SAH in these models is less clear. Further research, including direct comparative studies in non-human primates, is warranted to definitively establish the relative neuroprotective efficacy of Nimodipine and its alternatives.

## Experimental Protocols

Detailed methodologies are crucial for the replication and validation of these findings. Below are summarized protocols for key experiments cited in this guide.

### Primate Model of Focal Cerebral Ischemia (Middle Cerebral Artery Occlusion)

This protocol describes a common method for inducing a stroke in non-human primates.[16] [17][18]

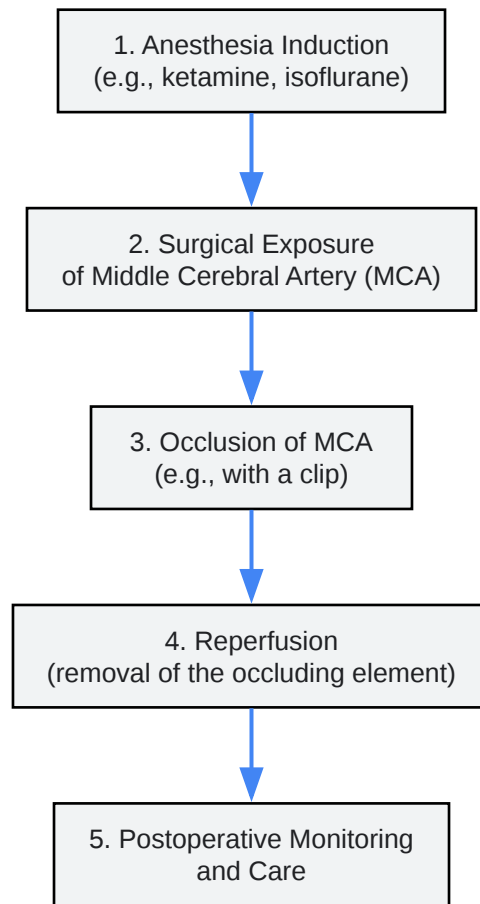

[Click to download full resolution via product page](#)

Caption: Experimental workflow for MCAO in primates.

- Animal Model: Baboons (*Papio*) or Macaques (*Macaca fascicularis*, *Macaca mulatta*) are commonly used.[3][5]
- Anesthesia: Animals are anesthetized, typically with an initial intramuscular injection followed by maintenance with an inhalant anesthetic.
- Surgical Procedure: A surgical approach, such as a transorbital or fronto-temporal craniotomy, is used to expose the middle cerebral artery (MCA).[16][19]
- Occlusion: The MCA is temporarily occluded using a microvascular clip or other methods for a defined period (e.g., 6 hours).[5]
- Reperfusion: The clip is removed to allow blood flow to return to the ischemic territory.

- Drug Administration: Nimodipine or the comparator agent is administered intravenously at a specified time relative to the occlusion.[5]
- Postoperative Monitoring: Physiological parameters such as intracranial pressure, blood pressure, and heart rate are monitored.[5]
- Neurological Assessment: Standardized neurological examinations are performed at set time points post-surgery to assess motor and sensory deficits.[3][5][20][21]
- Infarct Volume Measurement: At the end of the study period, animals are euthanized, and their brains are removed for histological analysis to quantify the volume of the infarct.[19][22][23]

## Primate Model of Subarachnoid Hemorrhage

This protocol outlines a method for inducing SAH in primates to study vasospasm.[6]

- Animal Model: Cynomolgus monkeys (*Macaca fascicularis*) are a frequently used species.[6][24]
- Anesthesia: Standard anesthetic procedures are followed.
- SAH Induction: An autologous blood clot is placed in the basal subarachnoid cisterns through a craniectomy.[6]
- Drug Administration: Oral Nimodipine or placebo is administered for a specified duration following the induction of SAH.[6]
- Angiography: Cerebral angiography is performed at baseline and at specified time points after SAH to assess the degree of vasospasm.[6]
- Neurological and Pathological Assessment: Neurological status is monitored, and upon completion of the study, brain tissue is collected for pathological examination.[6][7]

## Conclusion

The available evidence from primate models suggests that Nimodipine may offer a neuroprotective benefit in the context of ischemic stroke by improving neurological outcomes.

However, its efficacy in preventing cerebral vasospasm following subarachnoid hemorrhage in these models is not well-established. A significant limitation in the field is the lack of direct, head-to-head comparative studies of Nimodipine against newer neuroprotective agents in primate models. Such studies are essential to definitively determine the relative therapeutic potential of these compounds and to guide the selection of the most promising candidates for clinical translation. Researchers are encouraged to consider these gaps in the existing literature when designing future preclinical studies.

#### *Need Custom Synthesis?*

*BenchChem offers custom synthesis for rare earth carbides and specific isotopic labeling.*

*Email: [info@benchchem.com](mailto:info@benchchem.com) or [Request Quote Online](#).*

## References

- [1. taylorfrancis.com \[taylorfrancis.com\]](#)
- [2. Nimodipine Exerts Time-Dependent Neuroprotective Effect after Excitotoxic Damage in Organotypic Slice Cultures - PMC \[pmc.ncbi.nlm.nih.gov\]](#)
- [3. Nonhuman Primate Models of Stroke for Translational Neuroprotection Research - PMC \[pmc.ncbi.nlm.nih.gov\]](#)
- [4. Nonhuman primate models of stroke for translational neuroprotection research - PubMed \[pubmed.ncbi.nlm.nih.gov\]](#)
- [5. The efficacy of intravenous nimodipine in the treatment of focal cerebral ischemia in a primate model - PubMed \[pubmed.ncbi.nlm.nih.gov\]](#)
- [6. Nimodipine and chronic vasospasm in monkeys: Part 1. Clinical and radiological findings - PubMed \[pubmed.ncbi.nlm.nih.gov\]](#)
- [7. A randomized placebo-controlled double-blind trial of nimodipine after SAH in monkeys. Part 2: Pathological findings - PubMed \[pubmed.ncbi.nlm.nih.gov\]](#)
- [8. An experimental study of the effect of nimodipine in primate subarachnoid haemorrhage - PubMed \[pubmed.ncbi.nlm.nih.gov\]](#)
- [9. Beyond nimodipine: advanced neuroprotection strategies for aneurysmal subarachnoid hemorrhage vasospasm and delayed cerebral ischemia - PMC \[pmc.ncbi.nlm.nih.gov\]](#)
- [10. Beyond nimodipine: advanced neuroprotection strategies for aneurysmal subarachnoid hemorrhage vasospasm and delayed cerebral ischemia - PubMed](#)

[pubmed.ncbi.nlm.nih.gov]

- 11. Effect of Cilostazol in Animal Models of Cerebral Ischemia and Subarachnoid Hemorrhage: A Systematic Review and Meta-Analysis - PubMed [pubmed.ncbi.nlm.nih.gov]
- 12. Cilostazol attenuates cerebral vasospasm after experimental subarachnoid hemorrhage - PubMed [pubmed.ncbi.nlm.nih.gov]
- 13. Clazosentan, an endothelin receptor antagonist, in patients with aneurysmal subarachnoid haemorrhage undergoing surgical clipping: a randomised, double-blind, placebo-controlled phase 3 trial (CONSCIOUS-2) - PubMed [pubmed.ncbi.nlm.nih.gov]
- 14. The effectiveness and safety of clazosentan in treating aneurysmal subarachnoid hemorrhage: A systematic review and meta-analysis - PubMed [pubmed.ncbi.nlm.nih.gov]
- 15. Effect of clazosentan in patients with aneurysmal subarachnoid hemorrhage: a meta-analysis of randomized controlled trials - PubMed [pubmed.ncbi.nlm.nih.gov]
- 16. Development of a Middle Cerebral Artery Occlusion Model in the Nonhuman Primate and a Safety Study of I.V. Infusion of Human Mesenchymal Stem Cells | PLOS One [journals.plos.org]
- 17. An Enhanced Model of Middle Cerebral Artery Occlusion in Nonhuman Primates Using an Endovascular Trapping Technique - PMC [pmc.ncbi.nlm.nih.gov]
- 18. Nonhuman primate models of focal cerebral ischemia - PMC [pmc.ncbi.nlm.nih.gov]
- 19. Histochemical and morphometric investigation of the pathogenesis of acute brain infarction in primates - PubMed [pubmed.ncbi.nlm.nih.gov]
- 20. pubs.acs.org [pubs.acs.org]
- 21. ahajournals.org [ahajournals.org]
- 22. MAP2 Immunostaining in Thick Sections for Early Ischemic Stroke Infarct Volume in Non-Human Primate Brain - PMC [pmc.ncbi.nlm.nih.gov]
- 23. Temporal Evolution of Ischemic Lesions in Nonhuman Primates: A Diffusion and Perfusion MRI Study - PMC [pmc.ncbi.nlm.nih.gov]
- 24. Nimodipine and chronic vasospasm in monkeys: Part 2. Pharmacological studies of vessels in spasm - PubMed [pubmed.ncbi.nlm.nih.gov]
- To cite this document: BenchChem. [Validating the Neuroprotective Effects of Nimodipine in Primate Models: A Comparative Guide]. BenchChem, [2026]. [Online PDF]. Available at: [https://www.benchchem.com/product/b15554646/docs#validating-the-neuroprotective-effects-of-nimodipine-in-primate-models-a-comparative-guide]

**Disclaimer & Data Validity:**

The information provided in this document is for Research Use Only (RUO) and is strictly not intended for diagnostic or therapeutic procedures. While BenchChem strives to provide accurate protocols, we make no warranties, express or implied, regarding the fitness of this product for every specific experimental setup.

**Technical Support:** The protocols provided are for reference purposes. Unsure if this reagent suits your experiment?

**Need Industrial/Bulk Grade?** [Request Custom Synthesis Quote](#)

## BenchChem

Our mission is to be the trusted global source of essential and advanced chemicals, empowering scientists and researchers to drive progress in science and industry.

### Contact

Address: 3281 E Guasti Rd  
Ontario, CA 91761, United States  
Phone: (601) 213-4426  
Email: [info@benchchem.com](mailto:info@benchchem.com)

[Contact our Ph.D. Support Team for a compatibility check](#)