

Site-Specific Protein Labeling Using Sulfo-Cy5 Picolyl Azide: Application Notes and Protocols

Author: BenchChem Technical Support Team. **Date:** April 2026

Compound of Interest

Compound Name: Sulfo-Cy5 Picolyl Azide

Cat. No.: B15554612

[Get Quote](#)

For Researchers, Scientists, and Drug Development Professionals

Introduction

Site-specific protein labeling is a powerful tool in biological research and drug development, enabling precise studies of protein function, localization, and interactions.[1] This document provides detailed application notes and protocols for the site-specific labeling of proteins using **Sulfo-Cy5 Picolyl Azide**, a highly efficient fluorescent probe. This method leverages the principles of bioorthogonal click chemistry, specifically the copper(I)-catalyzed azide-alkyne cycloaddition (CuAAC), to attach the bright, far-red fluorescent dye Sulfo-Cy5 to a protein of interest with high specificity and efficiency.[2][3]

The use of a picolyl azide moiety in the Sulfo-Cy5 probe significantly enhances the CuAAC reaction. The picolyl group acts as a copper-chelating motif, which increases the effective concentration of the Cu(I) catalyst at the reaction site.[4][5] This results in a dramatically accelerated reaction rate, allowing for the use of lower copper concentrations, which improves the biocompatibility of the labeling procedure, a critical factor when working with sensitive biological systems.[4][5] Sulfo-Cy5 is a water-soluble and highly photostable cyanine dye,

making it an excellent choice for a wide range of applications, including fluorescence microscopy, flow cytometry, and in vivo imaging.[3]

Data Presentation

Table 1: Spectroscopic Properties of Sulfo-Cy5 Picolyl Azide

Property	Value	Reference
Excitation Maximum (λ_{exc})	~647-651 nm	[6][7][8][9]
Emission Maximum (λ_{em})	~663-671 nm	[7][8][9]
Extinction Coefficient (ϵ)	250,000 $\text{cm}^{-1}\text{M}^{-1}$	[4][7]
Molecular Weight	~953.11 g/mol	[4][7][8][9]
Solubility	Water, DMSO, DMF	[4][7][8][9]

Table 2: Comparison of Picolyl Azide-Mediated CuAAC with Conventional CuAAC

Feature	Picolyl Azide-Mediated CuAAC	Conventional CuAAC	Reference
Reaction Rate	Significantly faster	Slower	[4][5]
Required Copper Concentration	At least tenfold lower	Higher	[4][5]
Signal Intensity	Up to 40-fold increase reported	Lower	[5]
Biocompatibility	Improved due to lower copper	Potential for cytotoxicity	[10][11]

Experimental Protocols

Protocol 1: Introduction of an Alkyne Handle into the Target Protein

To utilize **Sulfo-Cy5 Picolyl Azide**, the target protein must first be modified to contain an alkyne group. This can be achieved through several methods, including metabolic labeling or enzymatic modification.

Method A: Metabolic Labeling with L-Homopropargylglycine (HPG)

This method is suitable for labeling newly synthesized proteins in cell culture.

Materials:

- Cells of interest
- Complete cell culture medium
- Methionine-free medium
- L-Homopropargylglycine (HPG)
- Phosphate-buffered saline (PBS)
- Cell lysis buffer (e.g., RIPA buffer)
- Protease inhibitors

Procedure:

- Culture cells to the desired confluency.
- Aspirate the complete medium and wash the cells once with warm PBS.
- Replace the medium with methionine-free medium and incubate for 1-2 hours to deplete endogenous methionine.
- Add HPG to the methionine-free medium to a final concentration of 25-50 μM .
- Incubate the cells for the desired period (e.g., 4-24 hours) to allow for HPG incorporation into newly synthesized proteins.
- Wash the cells twice with ice-cold PBS.

- Lyse the cells using a suitable lysis buffer containing protease inhibitors.
- Clarify the lysate by centrifugation and collect the supernatant containing the alkyne-modified proteome.

Method B: Enzymatic Labeling using Lipoic Acid Ligase (LplA)

This method allows for site-specific labeling of a protein containing a LplA acceptor peptide (LAP) tag.

Materials:

- Purified protein with a LAP tag
- Alkyne-modified substrate for LplA (e.g., an alkyne-containing lipoic acid analog)
- LplA enzyme
- ATP
- Reaction buffer (e.g., 50 mM Tris-HCl, pH 7.5, 10 mM MgCl₂)

Procedure:

- In a microcentrifuge tube, combine the purified LAP-tagged protein, the alkyne-modified substrate, LplA enzyme, and ATP in the reaction buffer.
- Incubate the reaction at the optimal temperature for the LplA enzyme (typically 30-37°C) for 1-2 hours.
- The alkyne-modified protein can then be purified from the reaction mixture using affinity chromatography if necessary.

Protocol 2: Click Chemistry Labeling with Sulfo-Cy5 Picolyl Azide

This protocol describes the CuAAC reaction between the alkyne-modified protein and **Sulfo-Cy5 Picolyl Azide**.

Materials:

- Alkyne-modified protein solution
- **Sulfo-Cy5 Picolyl Azide**
- Copper(II) sulfate (CuSO_4)
- Tris(3-hydroxypropyltriazolylmethyl)amine (THPTA) or other copper ligand
- Sodium ascorbate
- Reaction buffer (e.g., PBS or Tris buffer, pH 7.4)

Procedure:

- Prepare a stock solution of **Sulfo-Cy5 Picolyl Azide** in water or DMSO.
- Prepare fresh stock solutions of CuSO_4 , THPTA, and sodium ascorbate.
- In a microcentrifuge tube, add the alkyne-modified protein to the reaction buffer.
- Add **Sulfo-Cy5 Picolyl Azide** to the protein solution. A 5-10 fold molar excess of the azide over the protein is a good starting point.
- Premix the CuSO_4 and THPTA solutions. Add this mixture to the reaction tube. A final copper concentration of 50-100 μM is recommended.
- Initiate the click reaction by adding the sodium ascorbate solution (final concentration of 1-5 mM).
- Incubate the reaction for 1-2 hours at room temperature, protected from light.
- The reaction can be quenched by the addition of EDTA.

Protocol 3: Purification of the Labeled Protein

After the labeling reaction, it is essential to remove unreacted dye and other reaction components.

Method: Size Exclusion Chromatography (SEC)

Materials:

- Size exclusion chromatography column (e.g., Sephadex G-25)
- Equilibration and elution buffer (e.g., PBS)

Procedure:

- Equilibrate the SEC column with the chosen buffer.
- Carefully load the labeling reaction mixture onto the column.
- Elute the protein with the equilibration buffer. The labeled protein, being larger, will elute first, while the smaller, unreacted dye molecules will be retained longer on the column.
- Collect fractions and monitor the absorbance at 280 nm (for protein) and ~650 nm (for Sulfo-Cy5) to identify the fractions containing the labeled protein.
- Pool the fractions containing the purified, labeled protein.

Protocol 4: Characterization of the Labeled Protein

Method A: SDS-PAGE and In-Gel Fluorescence

Procedure:

- Separate the labeled protein from an unlabeled control using SDS-PAGE.
- Visualize the total protein by Coomassie blue or silver staining.
- Visualize the fluorescently labeled protein using a gel imager equipped with a Cy5-compatible excitation source and emission filter. A band should appear in the lane with the labeled protein at the expected molecular weight.

Method B: Mass Spectrometry

Mass spectrometry can be used to confirm the covalent attachment of the Sulfo-Cy5 label and to determine the labeling efficiency.

Visualizations

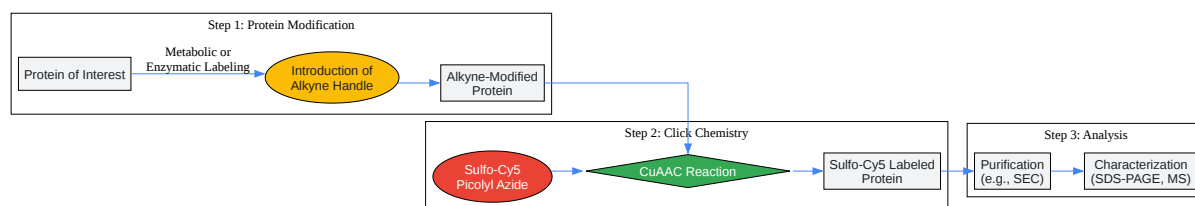

[Click to download full resolution via product page](#)

Caption: Experimental workflow for site-specific protein labeling.

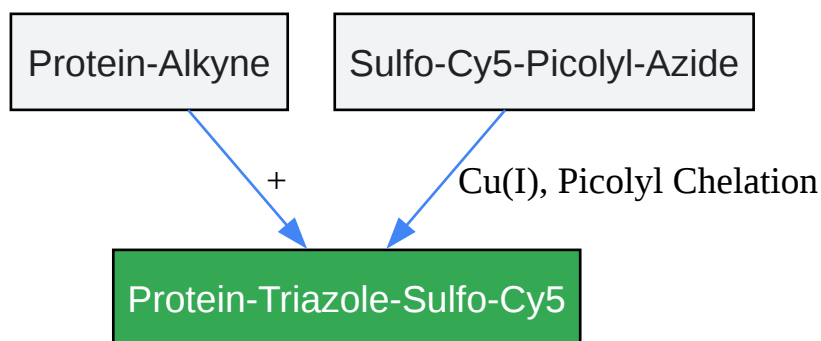

[Click to download full resolution via product page](#)

Caption: Copper-catalyzed azide-alkyne cycloaddition (CuAAC) reaction.

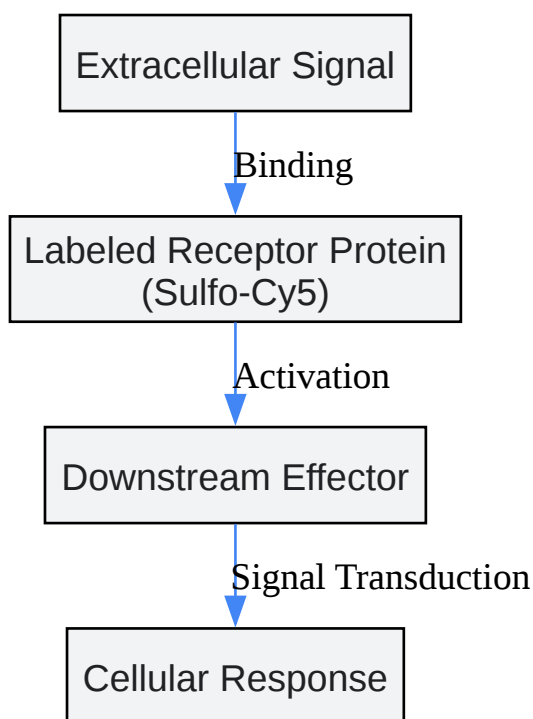

[Click to download full resolution via product page](#)

Caption: Example signaling pathway studied with a labeled protein.

Need Custom Synthesis?

BenchChem offers custom synthesis for rare earth carbides and specific isotopic labeling.

Email: info@benchchem.com or [Request Quote Online](#).

References

- [1. Protein Labeling: Methods and Mechanisms - Creative Proteomics \[creative-proteomics.com\]](#)
- [2. interchim.fr \[interchim.fr\]](#)
- [3. Sulfo Cyanine5 Dye | AxisPharm \[axispharm.com\]](#)
- [4. Sulfo Cy5 Picolyl Azide | AxisPharm \[axispharm.com\]](#)
- [5. vectorlabs.com \[vectorlabs.com\]](#)
- [6. medchemexpress.com \[medchemexpress.com\]](#)

- [7. Sulfo-Cy5 Picolyl Azide, 2669097-38-3 | BroadPharm \[broadpharm.com\]](#)
- [8. Picolyl-Azide-Sulfo-Cy5, Azide-containing Fluorescent Dyes - Jena Bioscience \[jenabioscience.com\]](#)
- [9. jenabioscience.com \[jenabioscience.com\]](#)
- [10. Click Chemistry—Section 3.1 | Thermo Fisher Scientific - JP \[thermofisher.com\]](#)
- [11. Frontiers | Specific and quantitative labeling of biomolecules using click chemistry \[frontiersin.org\]](#)
- To cite this document: BenchChem. [Site-Specific Protein Labeling Using Sulfo-Cy5 Picolyl Azide: Application Notes and Protocols]. BenchChem, [2026]. [Online PDF]. Available at: [\[https://www.benchchem.com/product/b15554612/docs#site-specific-protein-labeling-using-sulfo-cy5-picolyl-azide-application-notes-and-protocols\]](https://www.benchchem.com/product/b15554612/docs#site-specific-protein-labeling-using-sulfo-cy5-picolyl-azide-application-notes-and-protocols)

Disclaimer & Data Validity:

The information provided in this document is for Research Use Only (RUO) and is strictly not intended for diagnostic or therapeutic procedures. While BenchChem strives to provide accurate protocols, we make no warranties, express or implied, regarding the fitness of this product for every specific experimental setup.

Technical Support: The protocols provided are for reference purposes. Unsure if this reagent suits your experiment?

Need Industrial/Bulk Grade? [Request Custom Synthesis Quote](#)

BenchChem

Our mission is to be the trusted global source of essential and advanced chemicals, empowering scientists and researchers to drive progress in science and industry.

Contact

Address: 3281 E Guasti Rd
Ontario, CA 91761, United States
Phone: (601) 213-4426
Email: info@benchchem.com

Contact our Ph.D. Support Team for a compatibility check