

Nimodipine in Rodent Stroke Models: Detailed Application Notes and Protocols for Researchers

Author: BenchChem Technical Support Team. **Date:** April 2026

Compound of Interest

Compound Name: *Nimolinone*

Cat. No.: *B15554646*

[Get Quote](#)

For researchers, scientists, and drug development professionals, this document provides a comprehensive overview of the experimental use of nimodipine in rodent models of stroke. It includes detailed protocols, quantitative data summaries, and visualizations of relevant signaling pathways and experimental workflows.

Nimodipine, a dihydropyridine calcium channel blocker, has been extensively studied for its neuroprotective effects in the context of cerebral ischemia.^{[1][2]} Its primary mechanism of action involves the blockage of L-type voltage-gated calcium channels, which leads to cerebral vasodilation and may prevent neuronal calcium overload, a key event in the ischemic cascade.^{[2][3][4]} Animal models of stroke, primarily focal cerebral ischemia induced by middle cerebral artery occlusion (MCAO) and intracerebral hemorrhage (ICH), have been instrumental in elucidating the therapeutic potential and mechanisms of nimodipine.^{[5][6][7][8]}

Quantitative Data Summary

The following tables summarize the quantitative data from various studies on the use of nimodipine in rodent stroke models, focusing on dosage, administration route, timing, and key outcomes.

Table 1: Nimodipine Administration Protocols in Rodent Stroke Models

Rodent Model	Species	Nimodipine Dosage	Administration Route	Timing of Administration	Reference
Intracerebral Hemorrhage (ICH)	Mouse (ICR)	5 mg/kg	Intraperitoneal (i.p.)	Once daily, starting just before ICH induction, for a total of 4 doses	[1]
Middle Cerebral Artery Occlusion (MCAO)	Rat (Sprague Dawley)	30 μ g/hour/kg	Intravenous (i.v.) infusion	Started 5 minutes before MCAO	[5]
Middle Cerebral Artery Occlusion (MCAO)	Rat	Not specified	Not specified	1, 4, or 6 hours post-occlusion	[9]
Middle Cerebral Artery Occlusion (MCAO)	Rat (Fischer-344)	0.1 mg/kg	Subcutaneous (s.c.)	45 minutes before and 8 and 16 hours after MCAO	[7]
Ischemic Stroke	Rat	1 mg/kg/day	Not specified	Daily for 5 days post-stroke	[8]
Global Ischemia (11-VO)	Rat	0.025 μ g/100g/min	Local drip	During the 10-minute ischemic period	[6]

Focal Cerebral Ischemia	Rat	5 mg/kg	Intraperitoneal (i.p.)	30 min before, 1h during, or 3h after ischemia	[10]
Subarachnoid Hemorrhage	Rat	2 mg/kg/day	Intraperitoneal (i.p.)	30 min after induction	[11]

Table 2: Efficacy of Nimodipine in Rodent Stroke Models - Key Outcomes

Rodent Model	Species	Key Outcome Measure	Nimodipine Effect	Reference
Intracerebral Hemorrhage (ICH)	Mouse (ICR)	Cortical Blood Flow (CBF)	Markedly improved CBF	[1]
Forelimb Placing Performance	Improved performance	[1]		
Hematoma Volume & Brain Edema	No significant difference	[1]		
Middle Cerebral Artery Occlusion (MCAO)	Rat (Sprague Dawley)	Infarct Volume	Reduced from 20% to 15% of the brain	[5]
Middle Cerebral Artery Occlusion (MCAO)	Rat	Neurological Outcome	Improved neurological outcome when administered up to 6 hours post-occlusion	[9]
Infarct Size	Statistically smaller in nimodipine-treated groups	[9]		
Middle Cerebral Artery Occlusion (MCAO)	Rat (Fischer-344)	Infarct Size	No alteration at 6 hours, but considerable improvement at 12 and 24 hours	[7]
Brain Edema	Lower at 12 hours	[7]		
Ischemic Stroke	Rat	Cerebral Edema & BBB Integrity	Significant decrease in	[8]

cerebral edema
and maintenance
of BBB integrity

Cell Apoptosis, MMP-9 & ICAM- 1 Expression	Reduction in apoptosis and decreased expression	[8]		
Mitochondrial Function	Reduced mitochondrial swelling and ROS levels; restored mitochondrial membrane potential and SDH activity	[8]		
Subarachnoid Hemorrhage	Rat	Neurological Scores	Higher neurological scores	[11]
Brain Water Content	Lower brain water content	[11]		

Experimental Protocols

Middle Cerebral Artery Occlusion (MCAO) in Rats

This protocol describes the induction of focal cerebral ischemia via MCAO in rats, followed by the administration of nimodipine.

Materials:

- Male Sprague-Dawley rats (250-300g)
- Anesthesia: Ketamine and Xylazine, or Isoflurane
- Surgical instruments for craniotomy

- Microvascular clip (e.g., Biemer clip)
- Laser Doppler Flowmeter
- Nimodipine solution
- Infusion pump

Procedure:

- Anesthesia and Surgical Preparation: Anesthetize the rat (e.g., intraperitoneal injection of Xylazine and Ketamine).[5] Maintain body temperature at 37°C using a heating pad. Shave the surgical site and sterilize with an appropriate antiseptic.
- Surgical Procedure (Craniotomy): Perform a lateral craniotomy to expose the middle cerebral artery (MCA).[5]
- MCA Occlusion: Ligate the cerebral inferior vein and place a microvascular clip on the MCA near its origin for a predetermined duration (e.g., 60 minutes for transient MCAO).[5] Confirm successful occlusion by monitoring regional cerebral blood flow (rCBF) with a Laser Doppler Flowmeter. A significant drop in rCBF indicates successful occlusion.
- Nimodipine Administration:
 - Pre-treatment: Begin intravenous infusion of nimodipine (30 µg/hour/kg body-weight) 5 minutes before clipping the MCA.[5]
 - Post-treatment: Alternatively, administer nimodipine at specific time points (e.g., 1, 4, or 6 hours) after the onset of occlusion.[9]
- Reperfusion (for transient MCAO): After the occlusion period, remove the clip to allow for reperfusion. Confirm reperfusion by observing the restoration of rCBF.
- Post-operative Care: Suture the incision and provide post-operative analgesia as required. Monitor the animal for recovery.
- Outcome Assessment: At a predetermined time point (e.g., 24 hours post-MCAO), assess neurological deficits using a standardized scoring system. Subsequently, euthanize the

animal and perfuse the brain for histological analysis to determine the infarct volume.[5][9]

Intracerebral Hemorrhage (ICH) in Mice

This protocol outlines the induction of ICH in mice and subsequent treatment with nimodipine.

Materials:

- Male ICR mice (30-35g)
- Anesthesia: Chloral hydrate or Isoflurane
- Stereotaxic frame
- Hamilton syringe
- Autologous whole blood
- Nimodipine solution

Procedure:

- Anesthesia and Stereotaxic Fixation: Anesthetize the mouse and fix its head in a stereotaxic frame.
- ICH Induction:
 - Create a burr hole over the target brain region (e.g., caudate nucleus).
 - Slowly inject a specific volume of autologous whole blood (e.g., 30 μ L) into the caudate nucleus using a Hamilton syringe.[1]
- Nimodipine Administration: Administer nimodipine (5 mg/kg) via intraperitoneal injection immediately before the ICH induction and then every 24 hours for a total of four doses.[1]
- Post-operative Care: Remove the mouse from the stereotaxic frame and allow it to recover in a warm cage. Provide soft food and easy access to water.
- Outcome Assessment:

- Behavioral Testing: Perform behavioral tests (e.g., forelimb placing test) to assess neurological deficits at specific time points (e.g., 72 hours post-ICH).[1]
- Physiological Monitoring: Measure cortical blood flow using Laser Doppler Perfusion Measure (LDPM).[1]
- Histological Analysis: At the end of the experiment, euthanize the mouse, and remove the brain to determine hematoma volume and brain edema.[1]

Signaling Pathways and Experimental Workflow

Nimodipine's Neuroprotective Signaling Pathway

Nimodipine's neuroprotective effects are mediated, in part, through the activation of pro-survival signaling pathways. A key mechanism involves the activation of the PI3K/Akt and MEK/ERK pathways, leading to the phosphorylation and activation of the transcription factor CREB (cAMP response element-binding protein).[2][12] Activated CREB promotes the transcription of anti-apoptotic proteins (e.g., Bcl-2) and neurotrophic factors, while inhibiting the activity of pro-apoptotic proteins like caspases.[2]

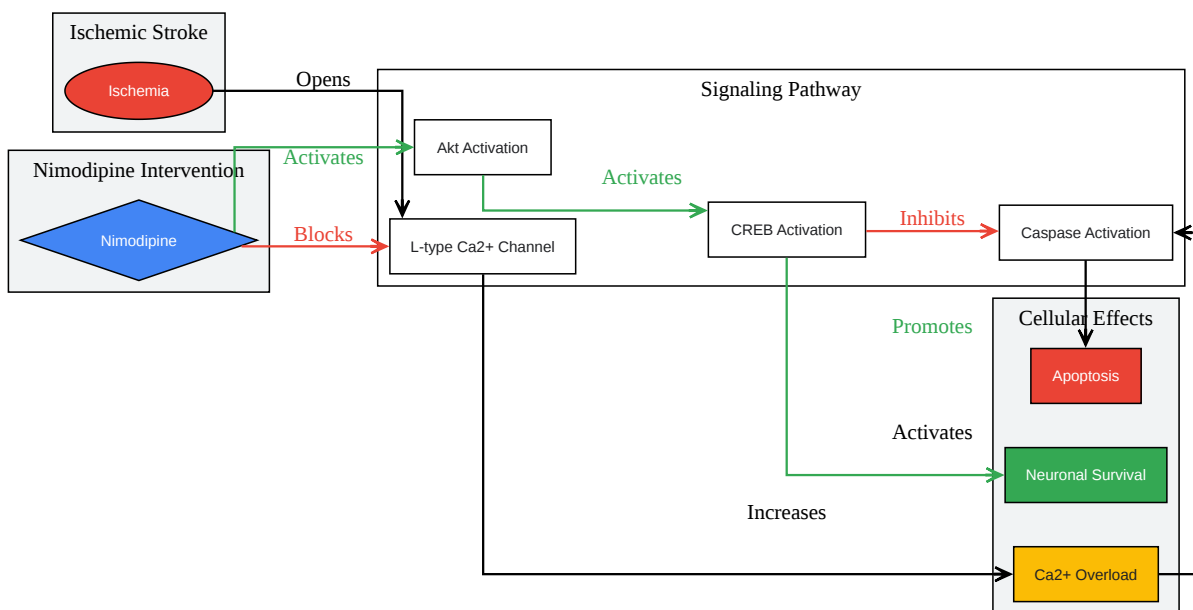

[Click to download full resolution via product page](#)

Caption: Nimodipine's neuroprotective signaling cascade in ischemic stroke.

Experimental Workflow for Nimodipine Testing in Rodent Stroke Models

The following diagram illustrates a typical experimental workflow for evaluating the efficacy of nimodipine in a rodent model of stroke.

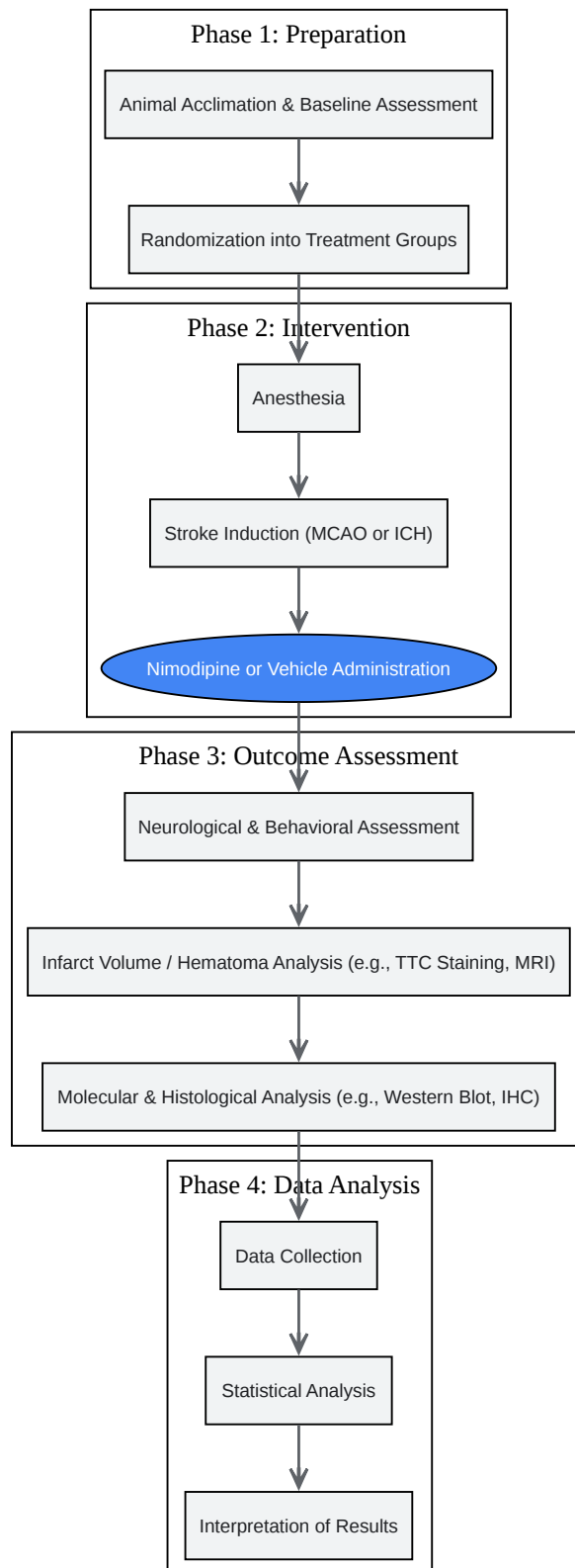

[Click to download full resolution via product page](#)

Caption: General experimental workflow for nimodipine studies in rodent stroke.

Need Custom Synthesis?

BenchChem offers custom synthesis for rare earth carbides and specific isotopic labeling.

Email: info@benchchem.com or [Request Quote Online](#).

References

- 1. Nimodipine treatment to assess a modified mouse model of intracerebral hemorrhage - PubMed [pubmed.ncbi.nlm.nih.gov]
- 2. [researchgate.net](https://www.researchgate.net) [[researchgate.net](https://www.researchgate.net)]
- 3. Nimodipine Protects Vascular and Cognitive Function in an Animal Model of Cerebral Small Vessel Disease - PMC [pubmed.ncbi.nlm.nih.gov]
- 4. [ahajournals.org](https://www.ahajournals.org) [[ahajournals.org](https://www.ahajournals.org)]
- 5. The effect of mannitol and nimodipine treatment in a rat model of temporary focal ischemia - PubMed [pubmed.ncbi.nlm.nih.gov]
- 6. [researchgate.net](https://www.researchgate.net) [[researchgate.net](https://www.researchgate.net)]
- 7. Effects of nimodipine on infarct size and cerebral acidosis after middle cerebral artery occlusion in the rat - PubMed [pubmed.ncbi.nlm.nih.gov]
- 8. reference.medscape.com [reference.medscape.com]
- 9. The therapeutic value of nimodipine in experimental focal cerebral ischemia. Neurological outcome and histopathological findings - PubMed [pubmed.ncbi.nlm.nih.gov]
- 10. Investigation of the Neuroprotective Impact of Nimodipine on Neuro2a Cells by Means of a Surgery-Like Stress Model - PMC [pubmed.ncbi.nlm.nih.gov]
- 11. [mdpi.com](https://www.mdpi.com) [[mdpi.com](https://www.mdpi.com)]
- 12. Nimodipine promotes neurite outgrowth and protects against neurotoxicity in PC12 cells - PMC [pubmed.ncbi.nlm.nih.gov]
- To cite this document: BenchChem. [Nimodipine in Rodent Stroke Models: Detailed Application Notes and Protocols for Researchers]. BenchChem, [2026]. [Online PDF]. Available at: [<https://www.benchchem.com/product/b15554646/docs#nimodipine-in-rodent-stroke-models-detailed-application-notes-and-protocols-for-researchers>]

Disclaimer & Data Validity:

The information provided in this document is for Research Use Only (RUO) and is strictly not intended for diagnostic or therapeutic procedures. While BenchChem strives to provide accurate protocols, we make no warranties, express or implied, regarding the fitness of this product for every specific experimental setup.

Technical Support: The protocols provided are for reference purposes. Unsure if this reagent suits your experiment?

Need Industrial/Bulk Grade? [Request Custom Synthesis Quote](#)

BenchChem

Our mission is to be the trusted global source of essential and advanced chemicals, empowering scientists and researchers to drive progress in science and industry.

Contact

Address: 3281 E Guasti Rd
Ontario, CA 91761, United States
Phone: (601) 213-4426
Email: info@benchchem.com

[Contact our Ph.D. Support Team for a compatibility check](#)