

5-TAMRA-DBCO for Fluorescence Microscopy: An In-Depth Technical Guide

Author: BenchChem Technical Support Team. **Date:** April 2026

Compound of Interest

Compound Name: 5-Tamra-dbcO

Cat. No.: B15554344

[Get Quote](#)

For Researchers, Scientists, and Drug Development Professionals

This guide provides a comprehensive overview of **5-TAMRA-DBCO**, a fluorescent probe widely utilized in fluorescence microscopy for the specific labeling of biomolecules. We will delve into its chemical properties, the underlying principles of its application in copper-free click chemistry, detailed experimental protocols, and data presentation for effective utilization in your research.

Introduction to 5-TAMRA-DBCO

5-TAMRA-DBCO is a fluorescent dye that combines the well-established fluorophore, 5-Carboxytetramethylrhodamine (5-TAMRA), with a dibenzocyclooctyne (DBCO) moiety. This unique combination makes it a powerful tool for bioorthogonal labeling. The TAMRA component provides a bright and photostable fluorescent signal, while the DBCO group enables highly specific and efficient covalent labeling of azide-modified molecules through a copper-free click chemistry reaction known as Strain-Promoted Azide-Alkyne Cycloaddition (SPAAC). This reaction is biocompatible, proceeding efficiently under physiological conditions without the need for a cytotoxic copper catalyst, making it ideal for live-cell imaging and in vivo studies.^{[1][2][3]}

The primary application of **5-TAMRA-DBCO** is the fluorescent labeling of proteins, peptides, nucleic acids, and other biomolecules that have been metabolically, enzymatically, or

chemically modified to contain an azide group.[3][4] Its bright fluorescence makes it suitable for a variety of applications, including fluorescence microscopy, flow cytometry, and immunofluorescence assays.[2]

Physicochemical and Spectroscopic Properties

Understanding the quantitative properties of **5-TAMRA-DBCO** is crucial for designing and interpreting fluorescence microscopy experiments. The key parameters are summarized in the table below. It is important to note that slight variations in these values can be found across different suppliers and experimental conditions.

Property	Value	Source(s)
Excitation Maximum (λ_{ex})	541 - 559 nm	[1][2][5][6][7]
Emission Maximum (λ_{em})	567 - 584 nm	[1][2][5][6][7]
Molar Extinction Coefficient (ϵ)	84,000 - 92,000 M ⁻¹ cm ⁻¹	[1][5][7]
Quantum Yield (Φ)	~0.1	[1][5]
Molecular Weight	~730.9 g/mol	[1]
Solubility	DMSO, DMF	[1][5]

The Chemistry of Labeling: Strain-Promoted Azide-Alkyne Cycloaddition (SPAAC)

The core of **5-TAMRA-DBCO**'s utility lies in its ability to participate in SPAAC. This reaction is a cornerstone of bioorthogonal chemistry, allowing for the specific chemical ligation of two molecules in a complex biological environment. The DBCO moiety of **5-TAMRA-DBCO** possesses significant ring strain, which drives a rapid and highly selective reaction with an azide-functionalized target molecule to form a stable triazole linkage.

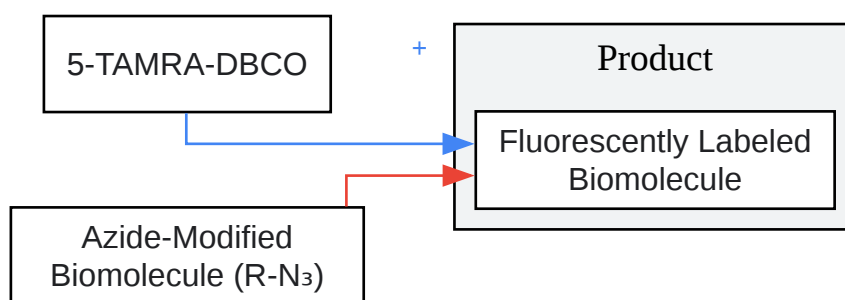

[Click to download full resolution via product page](#)

Diagram 1: The SPAAC reaction between **5-TAMRA-DBCO** and an azide-modified biomolecule.

This copper-free nature of the reaction is a significant advantage over the traditional copper-catalyzed click chemistry (CuAAC), as copper ions can be toxic to cells and interfere with biological processes.[8]

Experimental Protocols

The following are detailed protocols for the use of **5-TAMRA-DBCO** in labeling live cells and cell lysates. These are based on established methods for similar DBCO-fluorophore conjugates and should be optimized for your specific cell type and experimental setup.

Live Cell Labeling with 5-TAMRA-DBCO

This protocol is designed for labeling the surface of live cells that have been metabolically engineered to express azide groups on their glycans.

Materials:

- Mammalian cells cultured with an azide-derivatized metabolite (e.g., Ac₄ManNAz)
- **5-TAMRA-DBCO**
- Anhydrous DMSO or DMF
- Dulbecco's Phosphate-Buffered Saline (D-PBS) with 1% Fetal Bovine Serum (FBS)
- 4% Formaldehyde in D-PBS (for fixation)

- (Optional) Hoechst 33342 for nuclear counterstaining

Procedure:

- Cell Preparation: Grow mammalian cells in an appropriate medium containing an azide-derivatized metabolite (e.g., 25-50 μM Ac₄ManNAz) for 24-48 hours at 37°C in a 5% CO₂ incubator to allow for metabolic incorporation of the azide groups onto cell surface glycans.
- Washing: Gently wash the cells twice with pre-warmed D-PBS containing 1% FBS to remove any unincorporated azide sugars.
- Preparation of **5-TAMRA-DBCO** Stock Solution: Prepare a 5 mM stock solution of **5-TAMRA-DBCO** in anhydrous DMSO or DMF. For example, to prepare a 5 mM solution from 1 mg of **5-TAMRA-DBCO** (MW ~730.9 g/mol), dissolve it in approximately 274 μL of solvent. Vortex to ensure the solid is completely dissolved. This stock solution should be stored at -20°C, protected from light.
- Labeling Reaction: Dilute the **5-TAMRA-DBCO** stock solution in D-PBS with 1% FBS to a final working concentration of 5 to 30 μM . Add this labeling solution to the cells and incubate at room temperature in the dark for 30-60 minutes.^{[9][10]} The optimal concentration and incubation time should be determined empirically for each cell type and application.
- Washing: Wash the cells four times with D-PBS containing 1% FBS to remove any unreacted **5-TAMRA-DBCO**.
- Fixation: Fix the cells with 4% formaldehyde in D-PBS for 20 minutes at room temperature.
- Washing: Wash the cells twice with D-PBS.
- (Optional) Counterstaining: If desired, counterstain the cell nuclei by incubating with Hoechst 33342 in D-PBS for 15 minutes at room temperature.
- Washing: Wash the cells two times with D-PBS.
- Imaging: The cells are now ready for imaging using a fluorescence microscope with appropriate filters for the TAMRA fluorophore (Excitation/Emission ~541-559 nm / 567-584 nm).

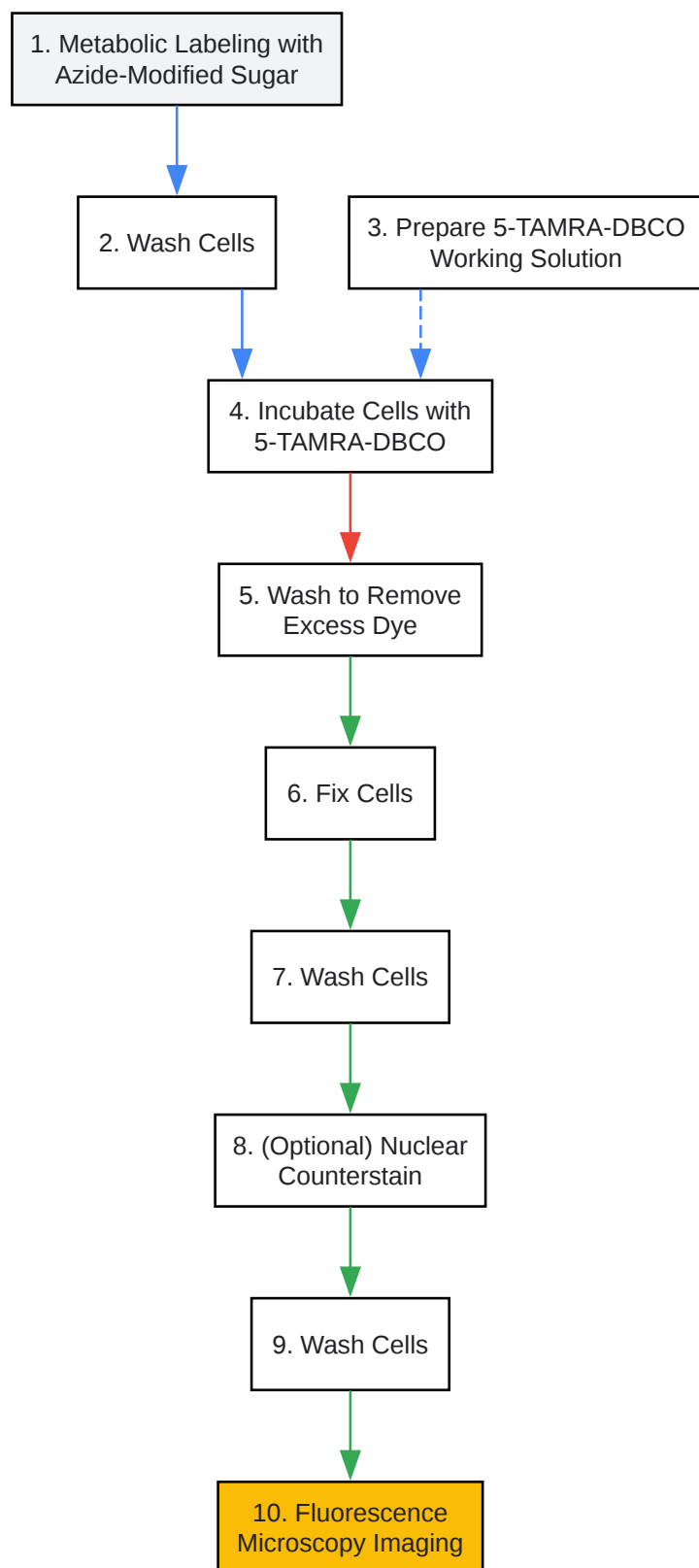

[Click to download full resolution via product page](#)

Need Custom Synthesis?

BenchChem offers custom synthesis for rare earth carbides and specific isotopic labeling.

Email: info@benchchem.com or [Request Quote Online](#).

References

- 1. TAMRA DBCO, 5-isomer, 1911598-65-6 | BroadPharm [broadpharm.com]
- 2. TAMRA DBCO, 5-isomer | CAS 1911598-65-6 (Equivalent of DyLight 549) | AxisPharm [axispharm.com]
- 3. medchemexpress.com [medchemexpress.com]
- 4. tenovapharma.com [tenovapharma.com]
- 5. lunanano.ca [lunanano.ca]
- 6. medchemexpress.com [medchemexpress.com]
- 7. prod-vector-labs-wordpress-media.s3.amazonaws.com [prod-vector-labs-wordpress-media.s3.amazonaws.com]
- 8. vectorlabs.com [vectorlabs.com]
- 9. static.igem.org [static.igem.org]
- 10. interchim.fr [interchim.fr]
- To cite this document: BenchChem. [5-TAMRA-DBCO for Fluorescence Microscopy: An In-Depth Technical Guide]. BenchChem, [2026]. [Online PDF]. Available at: [<https://www.benchchem.com/product/b15554344/docs#5-tamra-dbc0-for-fluorescence-microscopy-an-in-depth-technical-guide>]

Disclaimer & Data Validity:

The information provided in this document is for Research Use Only (RUO) and is strictly not intended for diagnostic or therapeutic procedures. While BenchChem strives to provide accurate protocols, we make no warranties, express or implied, regarding the fitness of this product for every specific experimental setup.

Technical Support: The protocols provided are for reference purposes. Unsure if this reagent suits your experiment?

Need Industrial/Bulk Grade? [Request Custom Synthesis Quote](#)

BenchChem

Our mission is to be the trusted global source of essential and advanced chemicals, empowering scientists and researchers to drive progress in science and industry.

Contact

Address: 3281 E Guasti Rd
Ontario, CA 91761, United States
Phone: (601) 213-4426
Email: info@benchchem.com

[Contact our Ph.D. Support Team for a compatibility check](#)