

Bodipy FL-C16 self-quenching and how to avoid it

Author: BenchChem Technical Support Team. **Date:** December 2025

Compound of Interest

Compound Name: Bodipy FL-C16

Cat. No.: B15553641

[Get Quote](#)

BODIPY™ FL C16 Technical Support Center

Welcome to the technical support center for BODIPY™ FL C16. This resource is designed to assist researchers, scientists, and drug development professionals in successfully utilizing this fluorescent fatty acid analog in their experiments. Here you will find troubleshooting guides, frequently asked questions (FAQs), detailed experimental protocols, and data to help you avoid common pitfalls such as self-quenching.

Frequently Asked Questions (FAQs)

Q1: What is BODIPY™ FL C16 and what is it used for?

BODIPY™ FL C16 is a fluorescently labeled long-chain fatty acid (palmitate) that is widely used in life sciences research. Its bright green fluorescence and fatty acid characteristics make it an excellent probe for studying cellular fatty acid uptake, lipid metabolism, and the localization of lipids within cells.[1][2] It is employed in various applications, including fluorescence microscopy, flow cytometry, and in vivo imaging to investigate metabolic processes in health and disease.

Q2: What is self-quenching and why does it occur with BODIPY™ FL C16?

Self-quenching, also known as aggregation-caused quenching (ACQ), is a phenomenon where the fluorescence intensity of a fluorophore decreases at high concentrations.[3] This occurs when the BODIPY™ FL C16 molecules are in close proximity to each other, leading to the

formation of non-fluorescent aggregates.[3] In these aggregates, the excited-state energy is dissipated through non-radiative pathways instead of being emitted as light, resulting in a diminished fluorescent signal.

Q3: How can I avoid BODIPY™ FL C16 self-quenching?

The most effective way to prevent self-quenching is to use the probe at an optimal, lower concentration. It is crucial to perform a concentration titration to determine the ideal concentration for your specific cell type and experimental setup. Additionally, ensuring the probe is fully solubilized and avoiding precipitation can help minimize aggregation. For in vitro studies, working concentrations are typically in the low micromolar range.

Q4: What are the excitation and emission wavelengths for BODIPY™ FL C16?

The approximate excitation and emission maxima for BODIPY™ FL C16 are 505 nm and 515 nm, respectively. These spectral properties make it compatible with standard green fluorescence filter sets, such as those for FITC.

Troubleshooting Guide

Issue	Possible Cause(s)	Recommended Solution(s)
<p>Weak or No Fluorescence Signal</p>	<p>1. Low Probe Concentration: The concentration of BODIPY™ FL C16 is too low for detection. 2. Inefficient Cellular Uptake: The cells are not taking up the probe effectively. 3. Photobleaching: The fluorophore has been damaged by excessive exposure to excitation light. 4. Incorrect Filter Set: The microscope filters do not match the excitation/emission spectra of the probe.</p>	<p>1. Optimize Concentration: Gradually increase the probe concentration. Refer to the recommended concentration table below. 2. Optimize Staining Conditions: Increase the incubation time or temperature. Ensure cells are healthy and metabolically active. 3. Minimize Light Exposure: Reduce the intensity of the excitation light and the duration of exposure. Use an anti-fade mounting medium for fixed cells. 4. Use Appropriate Filters: Ensure you are using a filter set suitable for green fluorescence (e.g., a standard FITC filter set).</p>
<p>High Background Fluorescence</p>	<p>1. Excess Probe: Unbound BODIPY™ FL C16 remains in the sample. 2. Probe Precipitation: The probe has formed aggregates that are non-specifically binding to surfaces. 3. Autofluorescence: The cells or medium have inherent fluorescence.</p>	<p>1. Thorough Washing: Increase the number and duration of washing steps with a suitable buffer (e.g., PBS) after incubation. 2. Ensure Solubilization: Prepare fresh working solutions and ensure the probe is fully dissolved. Consider using a carrier protein like fatty acid-free BSA. 3. Use Controls: Image unstained cells to determine the level of autofluorescence. Use a background subtraction algorithm if necessary.</p>

<p>Signal Appears Punctate or Aggregated</p>	<p>1. Probe Aggregation: BODIPY™ FL C16 has precipitated out of solution. 2. Localization to Lipid Droplets: The probe is accumulating in intracellular lipid droplets, which is a valid biological observation.</p>	<p>1. Improve Solubilization: Prepare the staining solution in a buffer containing a carrier, such as fatty acid-free bovine serum albumin (BSA), to improve solubility and facilitate cellular uptake. 2. Co-localization Studies: To confirm localization, co-stain with a known lipid droplet marker (e.g., Nile Red).</p>
--	--	---

<p>Inconsistent Results Between Experiments</p>	<p>1. Variability in Probe Preparation: Inconsistent preparation of stock and working solutions. 2. Differences in Cell Culture Conditions: Variations in cell density, health, or metabolic state. 3. Inconsistent Incubation Times or Temperatures: Fluctuations in experimental parameters.</p>	<p>1. Standardize Protocols: Prepare fresh solutions for each experiment and use precise pipetting techniques. 2. Maintain Consistent Cell Culture: Use cells at a consistent passage number and confluency. Ensure consistent growth conditions. 3. Control Experimental Parameters: Use a calibrated incubator and a timer to ensure consistent incubation conditions.</p>
---	--	--

Data Presentation

To avoid self-quenching, it is critical to use BODIPY™ FL C16 within its optimal concentration range. The following table provides recommended starting concentrations for various applications. It is highly recommended to perform a pilot experiment to determine the optimal concentration for your specific experimental conditions.

Application	Recommended Concentration Range	Notes
Live Cell Imaging	0.1 - 2 μ M	Start with a lower concentration and titrate up as needed. Higher concentrations can be cytotoxic.
Fixed Cell Staining	0.5 - 5 μ M	Higher concentrations may be tolerated by fixed cells, but can also lead to higher background.
Fatty Acid Uptake Assays (Plate Reader)	1 - 10 μ M	The optimal concentration will depend on the cell type and density.
In Vivo Imaging	200 μ M	This concentration has been optimized in some studies to achieve tissue-level concentrations that avoid self-quenching.[4][5][6]

Experimental Protocols

Protocol 1: Live-Cell Imaging of Fatty Acid Uptake

This protocol describes the staining of live cultured cells to visualize the uptake of BODIPY™ FL C16.

Materials:

- BODIPY™ FL C16 stock solution (e.g., 1 mM in DMSO)
- Live cells cultured in a suitable imaging dish or plate
- Serum-free cell culture medium
- Phosphate-buffered saline (PBS)

- Fatty acid-free Bovine Serum Albumin (BSA) (optional)

Procedure:

- Cell Preparation: Culture cells to the desired confluency (typically 70-80%) in a glass-bottom dish or chamber slide suitable for fluorescence microscopy.
- Prepare Staining Solution:
 - Prepare a working solution of BODIPY™ FL C16 in serum-free medium. A final concentration of 1-2 μM is a good starting point.
 - Optional: To enhance solubility and mimic physiological conditions, the BODIPY™ FL C16 can be complexed with fatty acid-free BSA. First, prepare a BSA-containing buffer and then add the BODIPY™ FL C16 stock solution.
- Cell Staining:
 - Remove the culture medium from the cells and wash once with warm PBS.
 - Add the BODIPY™ FL C16 staining solution to the cells.
 - Incubate at 37°C for 15-30 minutes. Protect from light.
- Washing:
 - Remove the staining solution and wash the cells 2-3 times with warm PBS to remove any unbound probe.
- Imaging:
 - Add fresh warm serum-free medium or PBS to the cells.
 - Image the cells immediately using a fluorescence microscope equipped with a standard FITC filter set (Excitation/Emission: ~488/515 nm).

Protocol 2: Staining of Fixed Cells

This protocol is for staining fixed cells to observe the intracellular distribution of the fatty acid analog.

Materials:

- BODIPY™ FL C16 stock solution (e.g., 1 mM in DMSO)
- Cells cultured on coverslips
- 4% Paraformaldehyde (PFA) in PBS
- PBS
- Mounting medium (preferably with an anti-fade reagent)

Procedure:

- Cell Fixation:
 - Remove the culture medium and wash the cells once with PBS.
 - Fix the cells by incubating with 4% PFA in PBS for 15 minutes at room temperature.
 - Wash the cells three times with PBS.
- Prepare Staining Solution:
 - Prepare a working solution of BODIPY™ FL C16 in PBS. A concentration of 1-5 μM is recommended.
- Staining:
 - Add the staining solution to the fixed cells and incubate for 20-30 minutes at room temperature, protected from light.
- Washing:
 - Remove the staining solution and wash the cells three times with PBS.

- Mounting and Imaging:
 - Mount the coverslips onto microscope slides using an anti-fade mounting medium.
 - Image using a fluorescence or confocal microscope.

Visualizations

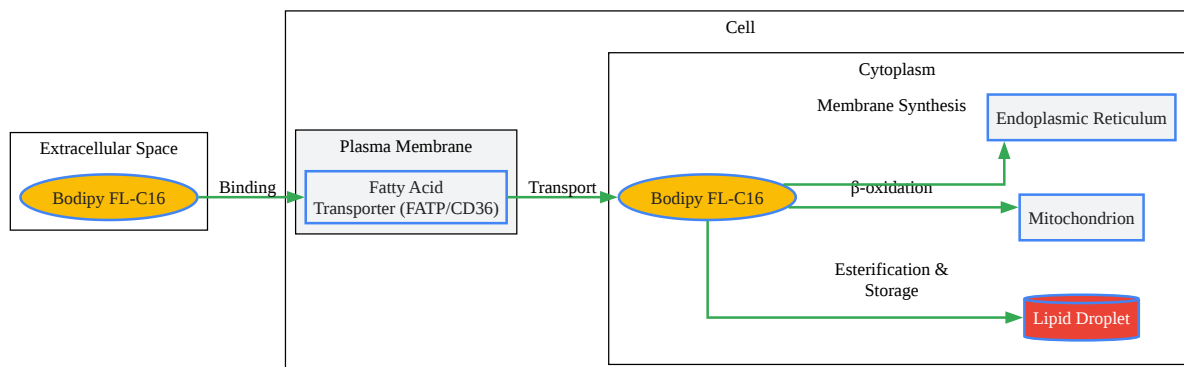

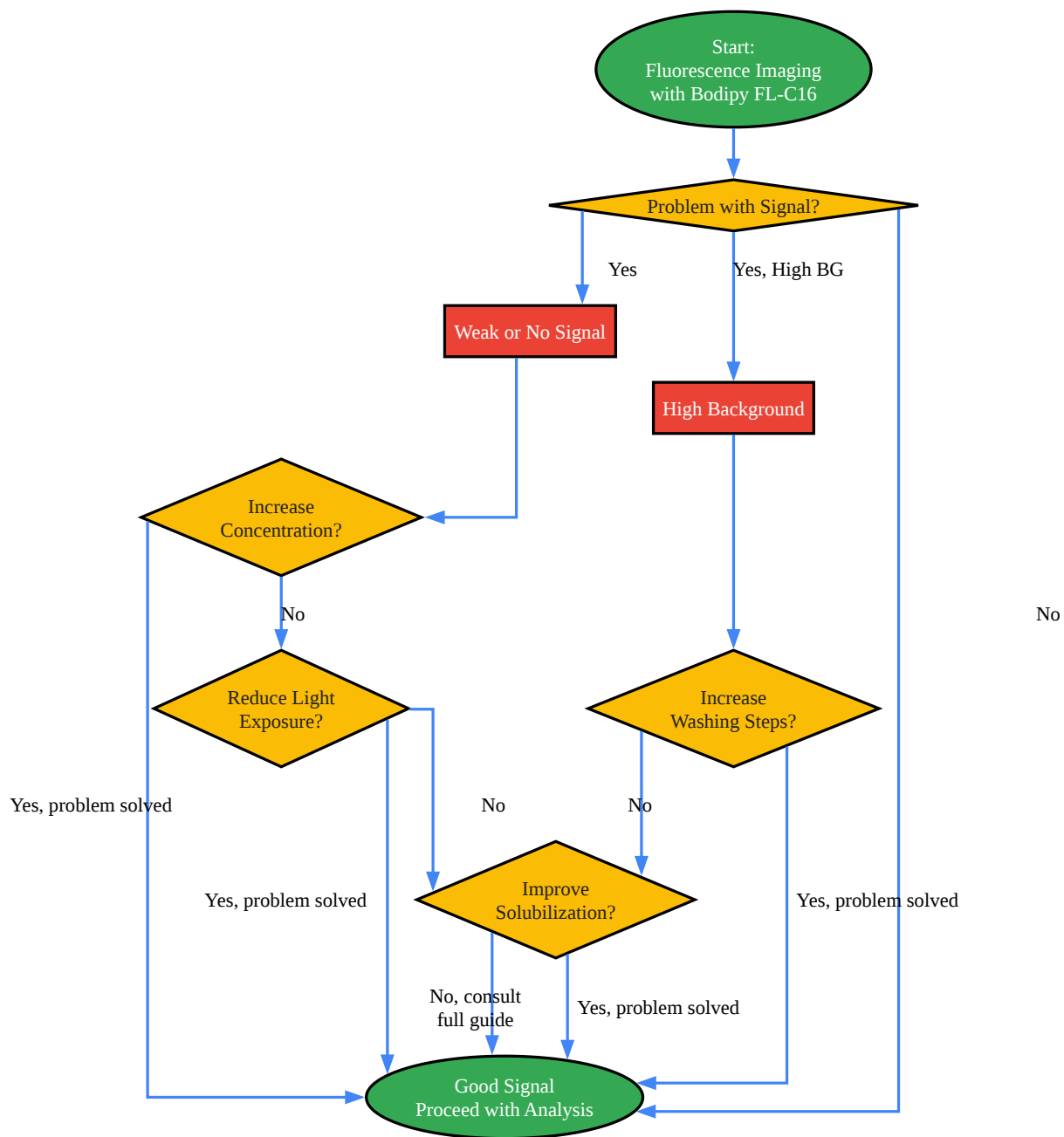

[Click to download full resolution via product page](#)

Need Custom Synthesis?

BenchChem offers custom synthesis for rare earth carbides and specific isotopic labeling.

Email: info@benchchem.com or [Request Quote Online](#).

References

- 1. BODIPY FL-C16 | Dye | Fatty acid | Lipid metabolism | TargetMol [targetmol.com]
- 2. medchemexpress.com [medchemexpress.com]
- 3. probes.bocsci.com [probes.bocsci.com]
- 4. researchgate.net [researchgate.net]
- 5. researchgate.net [researchgate.net]
- 6. researchgate.net [researchgate.net]
- To cite this document: BenchChem. [Bodipy FL-C16 self-quenching and how to avoid it]. BenchChem, [2025]. [Online PDF]. Available at: [<https://www.benchchem.com/product/b15553641#bodipy-fl-c16-self-quenching-and-how-to-avoid-it>]

Disclaimer & Data Validity:

The information provided in this document is for Research Use Only (RUO) and is strictly not intended for diagnostic or therapeutic procedures. While BenchChem strives to provide accurate protocols, we make no warranties, express or implied, regarding the fitness of this product for every specific experimental setup.

Technical Support: The protocols provided are for reference purposes. Unsure if this reagent suits your experiment? [[Contact our Ph.D. Support Team for a compatibility check](#)]

Need Industrial/Bulk Grade? [Request Custom Synthesis Quote](#)

BenchChem

Our mission is to be the trusted global source of essential and advanced chemicals, empowering scientists and researchers to drive progress in science and industry.

Contact

Address: 3281 E Guasti Rd

Ontario, CA 91761, United States

Phone: (601) 213-4426

Email: info@benchchem.com