

Application Notes and Protocols for AMCA-X SE Antibody Labeling

Author: BenchChem Technical Support Team. **Date:** April 2026

Compound of Interest

Compound Name: AMCA-X SE

Cat. No.: B15552252

[Get Quote](#)

For researchers, scientists, and drug development professionals, this document provides a detailed protocol for the covalent labeling of antibodies with **AMCA-X SE** (6-((7-Amino-4-methylcoumarin-3-acetyl)amino)hexanoic acid, succinimidyl ester), a blue fluorescent dye. The succinimidyl ester (SE) moiety readily reacts with primary amines on the antibody to form a stable carboxamide bond.

Introduction

AMCA-X SE is a derivative of the photostable and bright blue fluorophore, AMCA (7-amino-4-methylcoumarin-3-acetic acid). The "X" in its name refers to a six-carbon spacer that separates the fluorophore from its reactive group. This spacer helps to minimize potential quenching of the dye upon conjugation to a protein. **AMCA-X SE** is well-suited for multicolor fluorescence applications due to its distinct spectral properties, with an excitation maximum around 353 nm and an emission maximum around 442 nm.^{[1][2][3][4]} This protocol outlines the necessary steps for successful antibody conjugation, purification, and characterization.

Data Presentation

A summary of the key quantitative data for **AMCA-X SE** and its use in antibody labeling is provided in the table below for easy reference.

Parameter	Value
Molecular Weight of AMCA-X SE	443.46 g/mol [1][2][5]
Excitation Maximum (λ_{ex})	~353 nm[1][3][4]
Emission Maximum (λ_{em})	~442 nm[1][3][4]
Molar Extinction Coefficient of AMCA at 350 nm	19,000 M ⁻¹ cm ⁻¹
Molar Extinction Coefficient of AMCA at 280 nm	8,290 M ⁻¹ cm ⁻¹ [6]
Recommended Antibody Concentration	2 - 10 mg/mL
Recommended Molar Excess of Dye to Antibody (IgG)	10:1 to 20:1
Optimal Degree of Labeling (DOL)	2 - 10

Experimental Protocols

This section details the methodologies for antibody preparation, dye reconstitution, the conjugation reaction, and the purification and characterization of the labeled antibody.

Materials and Reagents

- Antibody to be labeled (at 2-10 mg/mL in an amine-free buffer)
- **AMCA-X SE**
- Anhydrous Dimethylformamide (DMF) or Dimethylsulfoxide (DMSO)
- Conjugation Buffer: 100 mM sodium bicarbonate or sodium borate buffer, pH 8.0-8.5
- Purification Resin: Gel filtration resin (e.g., Sephadex G-25) or a spin column
- Elution Buffer: Phosphate-buffered saline (PBS), pH 7.2-7.4
- Spectrophotometer
- Microcentrifuge tubes

Experimental Workflow

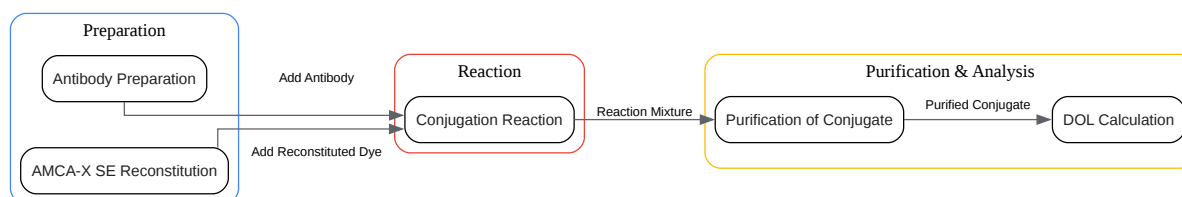

[Click to download full resolution via product page](#)

Caption: Experimental workflow for **AMCA-X SE** antibody labeling.

Detailed Protocol

- Antibody Preparation:
 - Ensure the antibody is in an amine-free buffer (e.g., PBS or MES). Buffers containing primary amines like Tris or glycine will compete with the antibody for reaction with the dye and should be avoided.[7]
 - The antibody concentration should be between 2 and 10 mg/mL for optimal labeling.
 - If necessary, exchange the buffer using dialysis or a desalting column.
 - Adjust the pH of the antibody solution to 8.0-8.5 by adding a small volume of 1 M sodium bicarbonate.
- **AMCA-X SE** Reconstitution:
 - Allow the vial of **AMCA-X SE** to warm to room temperature before opening to prevent moisture condensation.
 - Prepare a 10 mg/mL stock solution of **AMCA-X SE** in anhydrous DMF or DMSO. This should be done immediately before use as the succinimidyl ester is moisture-sensitive.[7]

- Conjugation Reaction:
 - Calculate the required volume of the **AMCA-X SE** stock solution to achieve the desired molar excess. A 10:1 to 20:1 molar ratio of dye to antibody is a good starting point for IgG.
 - Slowly add the calculated volume of the **AMCA-X SE** stock solution to the antibody solution while gently vortexing.
 - Incubate the reaction mixture for 1-2 hours at room temperature, protected from light.
- Purification of the Labeled Antibody:
 - Prepare a gel filtration column (e.g., Sephadex G-25) or a spin column according to the manufacturer's instructions, equilibrating with PBS.
 - Apply the reaction mixture to the top of the column.
 - Elute the labeled antibody with PBS. The labeled antibody will be in the first colored fraction to elute, while the smaller, unconjugated dye molecules will elute later.
 - Collect the fraction containing the labeled antibody.
- Characterization of the Labeled Antibody (Degree of Labeling Calculation):
 - Measure the absorbance of the purified antibody-dye conjugate at 280 nm (A280) and 350 nm (A350) using a spectrophotometer.
 - Calculate the concentration of the antibody and the degree of labeling (DOL) using the following equations:
 - Corrected A280 ($A_{280corr}$) = $A_{280} - (A_{350} \times 0.436)$
 - Where 0.436 is the correction factor ($CF = A_{280} \text{ of dye} / A_{350} \text{ of dye} = 8,290 / 19,000$)[6]
 - Antibody Concentration (M) = $A_{280corr} / \epsilon_{\text{antibody}}$

- Where $\epsilon_{\text{antibody}}$ is the molar extinction coefficient of the antibody at 280 nm (e.g., for IgG, $\epsilon \approx 210,000 \text{ M}^{-1}\text{cm}^{-1}$)
- Dye Concentration (M) = $A_{350} / \epsilon_{\text{dye}}$
- Where ϵ_{dye} is the molar extinction coefficient of AMCA-X at 350 nm (19,000 $\text{M}^{-1}\text{cm}^{-1}$)
- Degree of Labeling (DOL) = Dye Concentration (M) / Antibody Concentration (M)
- The optimal DOL is typically between 2 and 10.[8][9]
- Storage of the Labeled Antibody:
 - Store the purified, labeled antibody at 4°C for short-term storage (up to a few weeks) or at -20°C for long-term storage. Protect from light. Adding a cryoprotectant like glycerol to a final concentration of 50% is recommended for freezing.

Signaling Pathway and Reaction Mechanism

The following diagram illustrates the chemical reaction between the AMCA-X succinimidyl ester and a primary amine on the antibody.

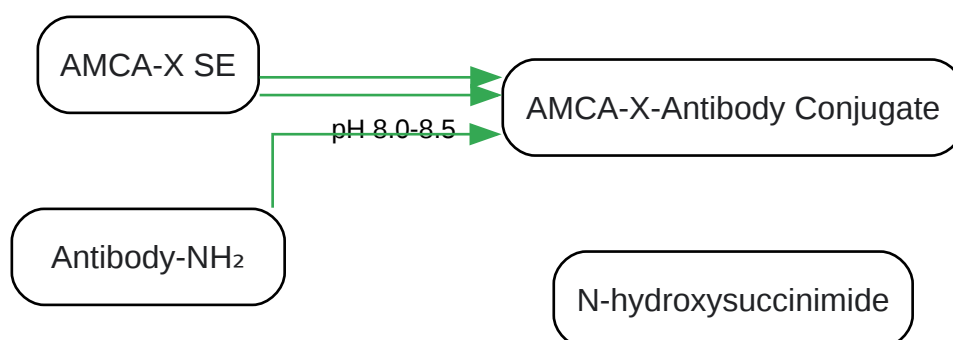

[Click to download full resolution via product page](#)

Caption: Reaction of **AMCA-X SE** with a primary amine on an antibody.

Need Custom Synthesis?

BenchChem offers custom synthesis for rare earth carbides and specific isotopic labeling.

Email: info@benchchem.com or [Request Quote Online](#).

References

- [1. biotium.com](https://www.biotium.com) [biotium.com]
- [2. abpbio.com](https://www.abpbio.com) [abpbio.com]
- [3. thomassci.com](https://www.thomassci.com) [thomassci.com]
- [4. AMCA-X, SE - Biotium](https://www.legacybiotium.com) [legacy.biotium.com]
- [5. abpbio.com](https://www.abpbio.com) [abpbio.com]
- [6. A spectrophotometric method for determination of fluorophore-to-protein ratios in conjugates of the blue fluorophore 7-amino-4-methylcoumarin-3-acetic acid \(AMCA\) - PubMed](#) [pubmed.ncbi.nlm.nih.gov]
- [7. medchemexpress.com](https://www.medchemexpress.com) [medchemexpress.com]
- [8. How to Determine the Degree of Labeling | AAT Bioquest](#) [aatbio.com]
- [9. Degree of Labeling \(DOL\) Calculator | AAT Bioquest](#) [aatbio.com]
- To cite this document: BenchChem. [Application Notes and Protocols for AMCA-X SE Antibody Labeling]. BenchChem, [2026]. [Online PDF]. Available at: [https://www.benchchem.com/product/b15552252/docs#application-notes-and-protocols-for-amca-x-se-antibody-labeling]

Disclaimer & Data Validity:

The information provided in this document is for Research Use Only (RUO) and is strictly not intended for diagnostic or therapeutic procedures. While BenchChem strives to provide accurate protocols, we make no warranties, express or implied, regarding the fitness of this product for every specific experimental setup.

Technical Support: The protocols provided are for reference purposes. Unsure if this reagent suits your experiment?

Need Industrial/Bulk Grade? [Request Custom Synthesis Quote](#)

BenchChem

Our mission is to be the trusted global source of essential and advanced chemicals, empowering scientists and researchers to drive progress in science and industry.

Contact

Address: 3281 E Guasti Rd
Ontario, CA 91761, United States
Phone: (601) 213-4426
Email: info@benchchem.com

[Contact our Ph.D. Support Team for a compatibility check](#)