

Technical Support Center: Aldox-D6 Ionization Efficiency and Matrix Effects

Author: BenchChem Technical Support Team. **Date:** April 2026

Compound of Interest

Compound Name: Aldox-D6
Cat. No.: B15551679

[Get Quote](#)

This technical support center provides researchers, scientists, and drug development professionals with comprehensive troubleshooting guides and frequently asked questions (FAQs) to address challenges related to matrix effects on **Aldox-D6** ionization efficiency in liquid chromatography-mass spectrometry (LC-MS/MS) analysis.

Frequently Asked Questions (FAQs)

Q1: What are matrix effects and how do they impact the analysis of **Aldox-D6**?

A1: Matrix effects are the alteration of ionization efficiency for a target analyte, such as **Aldox-D6**, due to the presence of co-eluting components from the sample matrix (e.g., plasma, urine, tissue extract).^{[1][2][3]} This interference can lead to either ion suppression (a decrease in signal) or, less commonly, ion enhancement (an increase in signal).^{[1][2]} Ultimately, uncorrected matrix effects can compromise the accuracy, precision, and sensitivity of the quantitative analysis of the target analyte that **Aldox-D6** is used to normalize.^{[4][5]}

Q2: I am using **Aldox-D6**, a stable isotope-labeled internal standard. Shouldn't that automatically correct for all matrix effects?

A2: Ideally, a stable isotope-labeled internal standard (SIL-IS) like **Aldox-D6** should co-elute with the unlabeled analyte and experience identical ionization suppression or enhancement, providing effective correction.[4][5] However, this is not always guaranteed. Minor differences in physicochemical properties between the analyte and its deuterated counterpart can sometimes lead to slight chromatographic separation.[2] If this separation occurs in a region of the chromatogram with varying matrix interferences, the analyte and **Aldox-D6** will be affected differently, leading to inaccurate quantification.[6]

Q3: My analyte/**Aldox-D6** peak area ratio is inconsistent across different biological samples. What is the likely cause?

A3: Inconsistent peak area ratios, despite using a SIL-IS, strongly suggest differential matrix effects.[2] This can occur if there is a slight retention time shift between your analyte and **Aldox-D6**, causing them to elute in regions with different levels of ion suppression.[2] Additionally, the composition and concentration of matrix components can vary significantly between different lots or sources of biological samples, leading to variable matrix effects.[7][8]

Q4: What are the primary sources of matrix effects in biological samples?

A4: In biological matrices such as plasma and serum, phospholipids are a major contributor to matrix effects, particularly ion suppression in electrospray ionization (ESI).[9][10] Other endogenous components like salts, proteins, and metabolites can also interfere with the ionization process.[1]

Troubleshooting Guide

This guide addresses specific issues you may encounter during your experiments in a question-and-answer format.

Problem 1: Low and inconsistent signal for **Aldox-D6** across different plasma lots.

- Possible Cause: Significant and variable ion suppression due to high concentrations of phospholipids and other endogenous components in different plasma lots.[8] Simple protein precipitation may not be sufficient to remove these interferences.[11]
- Recommended Actions:

- Optimize Sample Preparation: Implement more rigorous sample clean-up techniques to remove interfering matrix components.[4][12]
 - Liquid-Liquid Extraction (LLE): Can provide a cleaner extract than protein precipitation. [2]
 - Solid-Phase Extraction (SPE): Offers more selectivity in removing interferences.[10][11] Consider specialized SPE cartridges designed for phospholipid removal.[13]
- Chromatographic Optimization: Adjust the chromatographic method to separate **Aldox-D6** and the analyte from the regions of ion suppression.[4][14]
- Sample Dilution: Diluting the sample can reduce the concentration of interfering matrix components, but this is only feasible if the assay has sufficient sensitivity.[4][15]

Problem 2: Poor, asymmetric, or split peak shapes for both the analyte and **Aldox-D6**.

- Possible Cause: Issues with the analytical column, mobile phase composition, or sample solvent. Interactions with the stationary phase or system contamination can also lead to poor peak shapes.
- Recommended Actions:
 - Check Mobile Phase and Sample Solvent: Ensure the sample is dissolved in a solvent that is of similar or weaker strength than the initial mobile phase to avoid peak distortion.[16]
 - Evaluate Column Health: Contamination can lead to peak shape issues. Flush the system and consider using a guard column. If the problem persists, the analytical column may need to be replaced.
 - Adjust Mobile Phase: Modify the mobile phase composition or gradient to improve peak shape.

Problem 3: The retention times of the analyte and **Aldox-D6** are slightly different, leading to inconsistent results.

- Possible Cause: The "deuterium isotope effect" can sometimes cause a slight difference in retention time between the analyte and its deuterated internal standard on reversed-phase columns.[6]
- Recommended Actions:
 - Modify Mobile Phase Gradient: A shallower gradient around the elution time of the analyte and **Aldox-D6** can improve their co-elution.[2]
 - Change Organic Modifier: Switching from acetonitrile to methanol (or vice versa) can alter selectivity and may improve co-elution.[2]
 - Adjust Column Temperature: Modifying the column temperature can influence retention times and potentially improve co-elution.[2]

Experimental Protocols

Protocol 1: Quantitative Assessment of Matrix Effect (Post-Extraction Addition)

This method quantifies the extent of ion suppression or enhancement.[3][5]

Methodology:

- Prepare Three Sets of Samples:
 - Set A (Neat Solution): Prepare a standard solution of your analyte and **Aldox-D6** in the final mobile phase or reconstitution solvent at a known concentration (e.g., Low and High QC levels).
 - Set B (Post-Extraction Spike): Process at least six different lots of blank biological matrix through your entire sample preparation procedure. Spike the resulting blank extracts with the analyte and **Aldox-D6** to the same final concentration as Set A.[5][17]
 - Set C (Pre-Extraction Spike): Spike the blank biological matrix with the analyte and **Aldox-D6** at the same concentration as Set A before the extraction process. (This set is used for recovery calculation).

- LC-MS/MS Analysis: Analyze all three sets of samples using your established LC-MS/MS method.
- Data Analysis:
 - Calculate Matrix Factor (MF):
 - $MF = (\text{Peak Area in Set B}) / (\text{Peak Area in Set A})$
 - An MF value of 1 indicates no matrix effect.
 - An MF value < 1 indicates ion suppression.[8]
 - An MF value > 1 indicates ion enhancement.[8]
 - Calculate IS-Normalized Matrix Factor:
 - $\text{IS-Normalized MF} = (\text{MF of Analyte}) / (\text{MF of Aldox-D6})$
 - Calculate Recovery:
 - $\text{Recovery (\%)} = [(\text{Peak Area in Set C}) / (\text{Peak Area in Set B})] * 100$

Acceptance Criteria: The coefficient of variation (CV%) of the IS-Normalized Matrix Factor across the different lots of matrix should not be greater than 15%.[17]

Protocol 2: Qualitative Assessment of Matrix Effect (Post-Column Infusion)

This experiment identifies at which retention times matrix effects occur.[3][4]

Methodology:

- System Setup: Infuse a standard solution of your analyte at a constant flow rate into the MS detector, post-column, using a T-connector.
- Injection: While the analyte solution is being infused, inject a blank, extracted matrix sample onto the LC column.

- Data Acquisition: Monitor the signal intensity of the infused analyte over the entire chromatographic run.
- Data Analysis:
 - A stable, flat baseline indicates no matrix effect.
 - Any dips in the baseline correspond to regions of ion suppression, while peaks indicate ion enhancement.[3]
 - Compare the retention time of your analyte and **Aldox-D6** with the regions of ion suppression/enhancement to assess the potential for impact on your results.

Data Presentation

Table 1: Hypothetical Matrix Factor (MF) and Recovery Data for Analyte X and **Aldox-D6**

Lot ID	Analyte MF	Aldox-D6 MF	IS-Normalized MF	Analyte Recovery (%)
Plasma 1	0.65	0.68	0.96	88.2
Plasma 2	0.72	0.75	0.96	90.1
Plasma 3	0.59	0.63	0.94	85.6
Plasma 4	0.81	0.83	0.98	92.5
Plasma 5	0.68	0.70	0.97	89.3
Plasma 6	0.75	0.79	0.95	91.0
Mean	0.70	0.73	0.96	89.5
%CV	11.5	9.8	1.5	2.9

This table illustrates significant but consistent ion suppression for both the analyte and **Aldox-D6** across different plasma lots. The low %CV for the IS-Normalized MF demonstrates that **Aldox-D6** effectively compensates for the matrix effect.

Visualizations

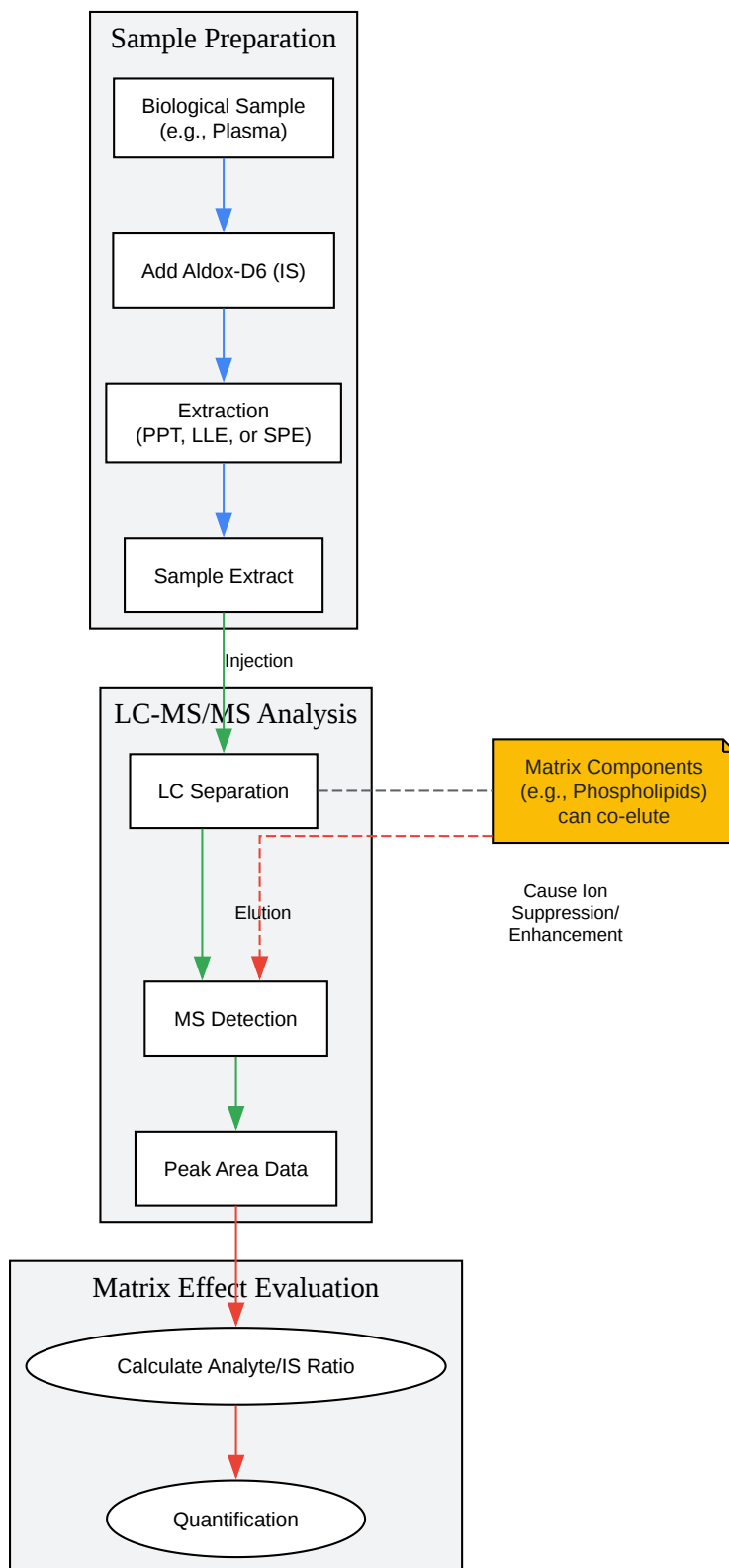

[Click to download full resolution via product page](#)

Caption: Workflow for bioanalysis and the point of interference from matrix components.

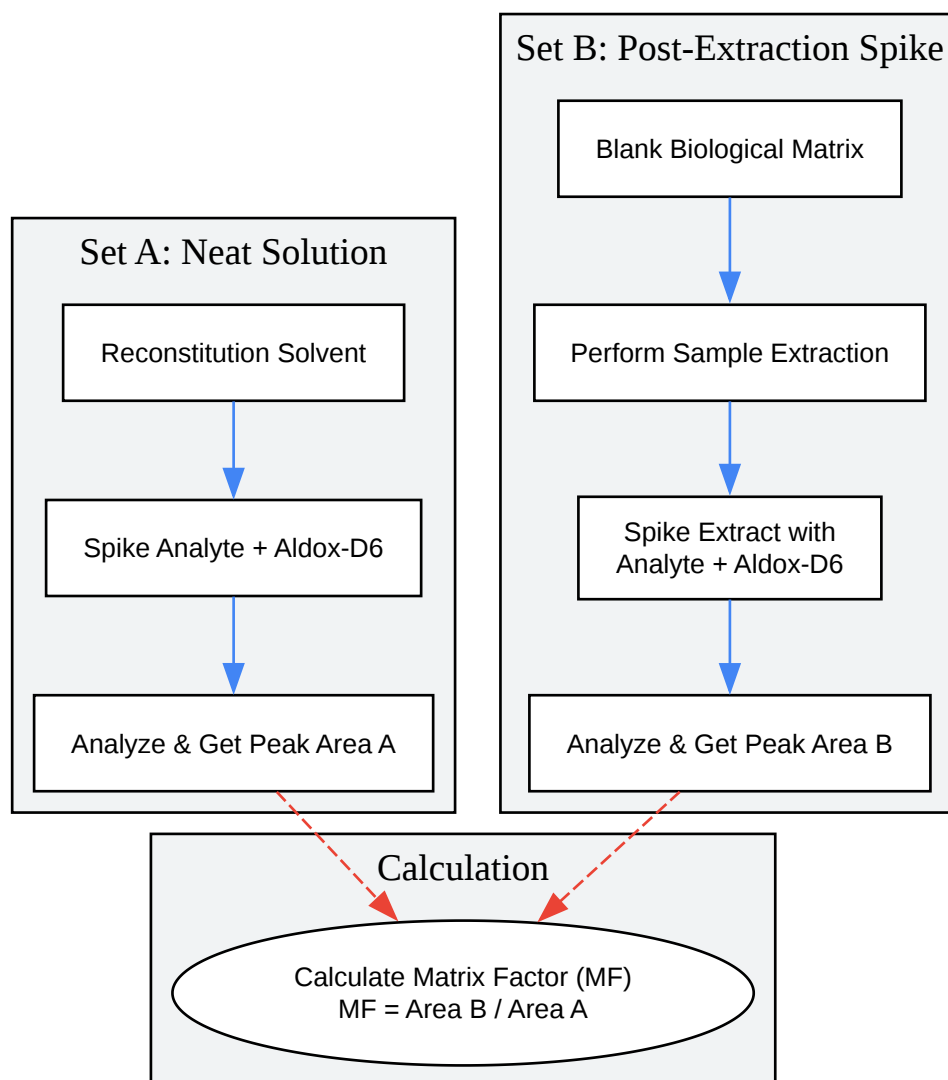

[Click to download full resolution via product page](#)

Caption: Experimental workflow for the quantitative assessment of matrix effects.

Need Custom Synthesis?

BenchChem offers custom synthesis for rare earth carbides and specific isotopic labeling.

Email: info@benchchem.com or [Request Quote Online](#).

References

- 1. longdom.org [longdom.org]
- 2. benchchem.com [benchchem.com]
- 3. benchchem.com [benchchem.com]
- 4. chromatographyonline.com [chromatographyonline.com]
- 5. benchchem.com [benchchem.com]
- 6. researchgate.net [researchgate.net]
- 7. A stable isotope-labeled internal standard is essential for correcting for the interindividual variability in the recovery of lapatinib from cancer patient plasma in quantitative LC-MS/MS analysis - PMC [pmc.ncbi.nlm.nih.gov]
- 8. benchchem.com [benchchem.com]
- 9. Matrix effects caused by phospholipids in multi-residue analysis for beta-agonists with liquid chromatography-electrospray tandem mass spectrometry - RSC Advances (RSC Publishing) [pubs.rsc.org]
- 10. americanpharmaceuticalreview.com [americanpharmaceuticalreview.com]
- 11. benchchem.com [benchchem.com]
- 12. chromatographyonline.com [chromatographyonline.com]
- 13. HybridSPE: A novel technique to reduce phospholipid-based matrix effect in LC-ESI-MS Bioanalysis - PubMed [pubmed.ncbi.nlm.nih.gov]
- 14. documents.thermofisher.com [documents.thermofisher.com]
- 15. Compensate for or Minimize Matrix Effects? Strategies for Overcoming Matrix Effects in Liquid Chromatography-Mass Spectrometry Technique: A Tutorial Review - PMC [pmc.ncbi.nlm.nih.gov]
- 16. benchchem.com [benchchem.com]
- 17. e-b-f.eu [e-b-f.eu]
- To cite this document: BenchChem. [Technical Support Center: Aldox-D6 Ionization Efficiency and Matrix Effects]. BenchChem, [2026]. [Online PDF]. Available at: [<https://www.benchchem.com/product/b15551679/docs#technical-support-center-aldox-d6-ionization-efficiency-and-matrix-effects>]

Disclaimer & Data Validity:

The information provided in this document is for Research Use Only (RUO) and is strictly not intended for diagnostic or therapeutic procedures. While BenchChem strives to provide accurate protocols, we make no warranties, express or implied, regarding the fitness of this product for every specific experimental setup.

Technical Support: The protocols provided are for reference purposes. Unsure if this reagent suits your experiment?

Need Industrial/Bulk Grade? [Request Custom Synthesis Quote](#)

BenchChem

Our mission is to be the trusted global source of essential and advanced chemicals, empowering scientists and researchers to drive progress in science and industry.

Contact

Address: 3281 E Guasti Rd
Ontario, CA 91761, United States
Phone: (601) 213-4426
Email: info@benchchem.com

[Contact our Ph.D. Support Team for a compatibility check](#)