

Pentadecaprenol vs. Dolichol: A Comparative Guide to Glycosylation Efficiency

Author: BenchChem Technical Support Team. **Date:** December 2025

Compound of Interest

Compound Name: Pentadecaprenol

Cat. No.: B15548959

[Get Quote](#)

For Researchers, Scientists, and Drug Development Professionals

The efficiency of N-linked glycosylation, a critical post-translational modification influencing protein folding, stability, and function, is highly dependent on the lipid carrier molecule that transports the oligosaccharide precursor. In eukaryotes, this role is primarily fulfilled by dolichol, an α -saturated polyisoprenoid. This guide provides a comparative analysis of the glycosylation efficiency of **pentadecaprenol**, a C75 polyprenol, and dolichol, supported by available experimental insights.

Executive Summary

Experimental evidence indicates that mammalian glycosyltransferases exhibit a distinct preference for dolichol-phosphate over polyprenol-phosphate as a substrate for oligosaccharide synthesis. This preference translates to a higher glycosylation efficiency for dolichol-based carriers. While specific kinetic data for **pentadecaprenol** (C75) is not readily available, studies on general polyprenols reveal that their unsaturated α -isoprene unit leads to less favorable enzyme kinetics compared to the saturated α -unit of dolichols.

Data Presentation: Kinetic Parameters

The following table summarizes the qualitative comparison of the apparent kinetic parameters (K_m and V_{max}) of key glycosyltransferases involved in N-linked glycosylation when utilizing either dolichol-phosphate or polyprenol-phosphate based substrates. A lower K_m indicates higher enzyme affinity for the substrate, while a higher V_{max} indicates a faster reaction rate.

Glycosyltransferase	Substrate	Apparent Km	Apparent Vmax	Implication for Efficiency
dolichyl-P-mannose:Man5(GlcNAc)2-PP-dolichol mannosyltransferase	Dolichyl-P-mannose	Lower	Higher	Higher Efficiency
Polyprenyl-P-mannose	Higher	Lower	Lower	Lower Efficiency
dolichyl-P-glucose:Man9(GlcNAc)2-PP-dolichol glucosyltransferase	Dolichyl-P-glucose	Lower	Higher	Higher Efficiency
Polyprenyl-P-glucose	Higher	Lower	Lower	Lower Efficiency

Table 1: Qualitative comparison of kinetic parameters for glycosyltransferases with dolichol and polyprenol-based substrates. Data is based on findings that show mammalian glycosyltransferases have higher apparent Kms and lower apparent Vmaxs for polyprenyl-P-monosaccharides[1].

Experimental Protocols

While the precise, detailed protocol from the direct comparative study is not publicly available, a general methodology for an in vitro glycosylation assay to compare the efficiency of **pentadecaprenol** and dolichol as glycosyl carriers can be outlined as follows.

Objective: To determine the kinetic parameters (Km and Vmax) of a specific glycosyltransferase (e.g., mannosyltransferase) using either pentadecaprenyl-phosphate-mannose or dolichyl-phosphate-mannose as the donor substrate.

Materials:

- Microsomal preparations from a suitable cell line (e.g., CHO cells) as a source of glycosyltransferases.
- **Pentadecaprenol** and dolichol standards.
- Radiolabeled sugar nucleotide (e.g., GDP-[¹⁴C]Mannose).
- Acceptor substrate (e.g., Man5(GlcNAc)₂-PP-dolichol).
- Buffer solutions (e.g., Tris-HCl with appropriate pH).
- Detergent (e.g., Triton X-100) for solubilizing lipids and enzymes.
- Thin-layer chromatography (TLC) plates and solvent systems.
- Scintillation counter.

Methodology:

- Preparation of Donor Substrates: Synthesize pentadecaprenyl-phosphate and dolichyl-phosphate. Subsequently, generate the mannosylated forms (pentadecaprenyl-P-mannose and dolichyl-P-mannose) enzymatically using a mannosyltransferase and GDP-Mannose.
- Enzyme Assay:
 - Set up reaction mixtures containing:
 - Microsomal enzyme preparation.
 - A fixed concentration of the acceptor substrate.
 - Varying concentrations of the donor substrate (either [¹⁴C]pentadecaprenyl-P-mannose or [¹⁴C]dolichyl-P-mannose).
 - Reaction buffer containing a detergent.
 - Incubate the reactions at an optimal temperature (e.g., 37°C) for a defined period.

- Stop the reaction by adding a solvent mixture (e.g., chloroform/methanol).
- Product Separation and Quantification:
 - Extract the lipid-linked oligosaccharides.
 - Separate the radiolabeled product from the unreacted donor substrate using TLC.
 - Quantify the amount of product formed by scintillation counting of the corresponding spots on the TLC plate.
- Data Analysis:
 - Plot the initial reaction velocities against the varying concentrations of the donor substrate.
 - Determine the apparent K_m and V_{max} values for each donor substrate by fitting the data to the Michaelis-Menten equation using a suitable software (e.g., Lineweaver-Burk or non-linear regression analysis).

Mandatory Visualization

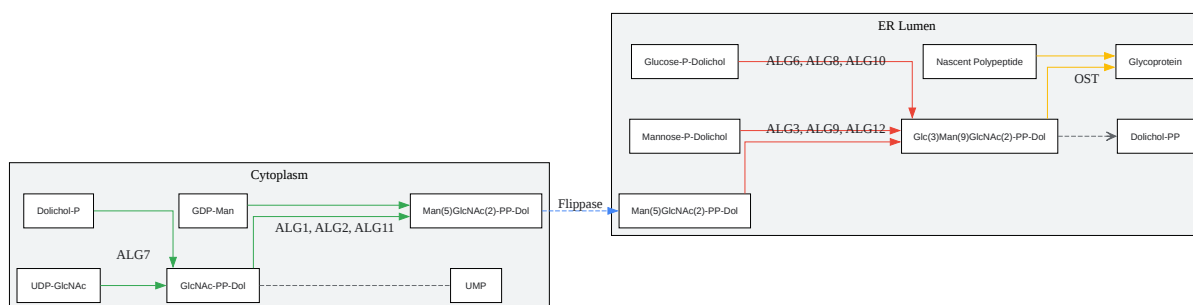

[Click to download full resolution via product page](#)

Caption: N-Linked Glycosylation Pathway.

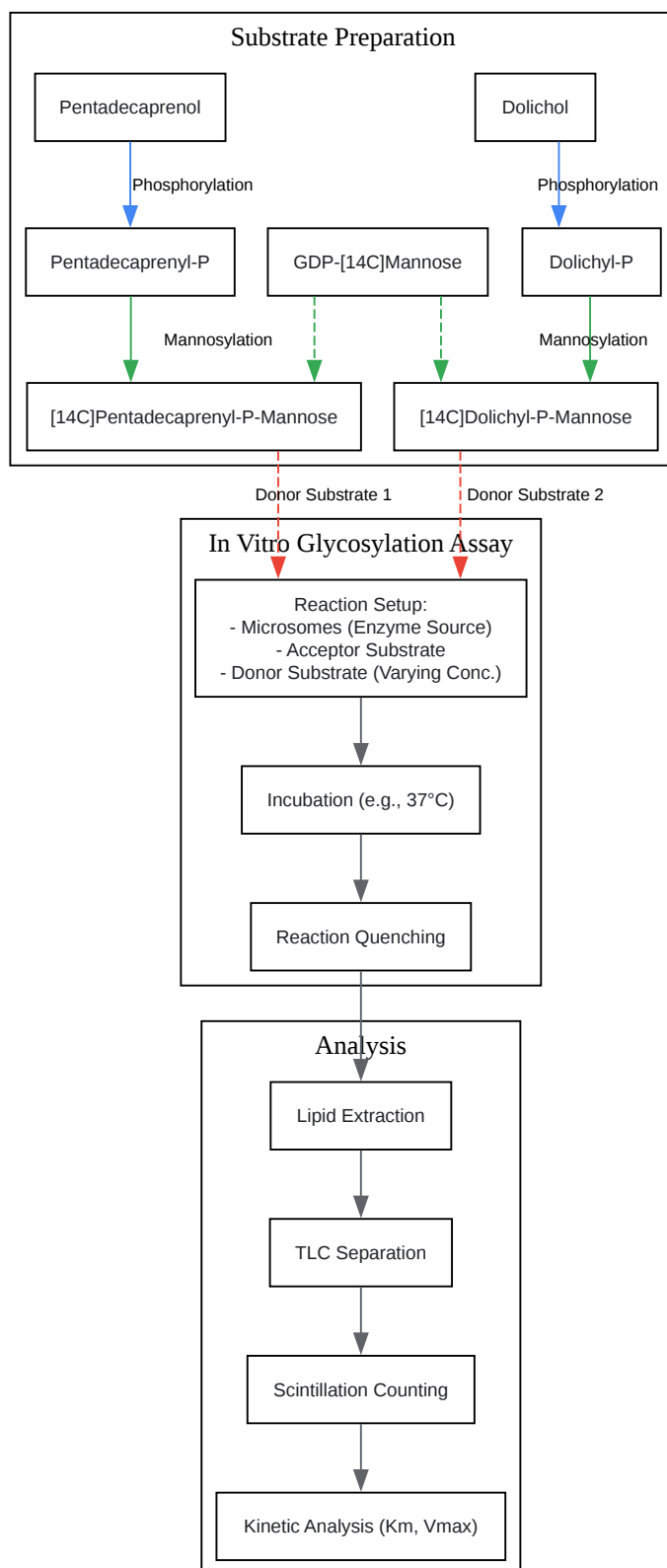

[Click to download full resolution via product page](#)

Caption: In Vitro Glycosylation Assay Workflow.

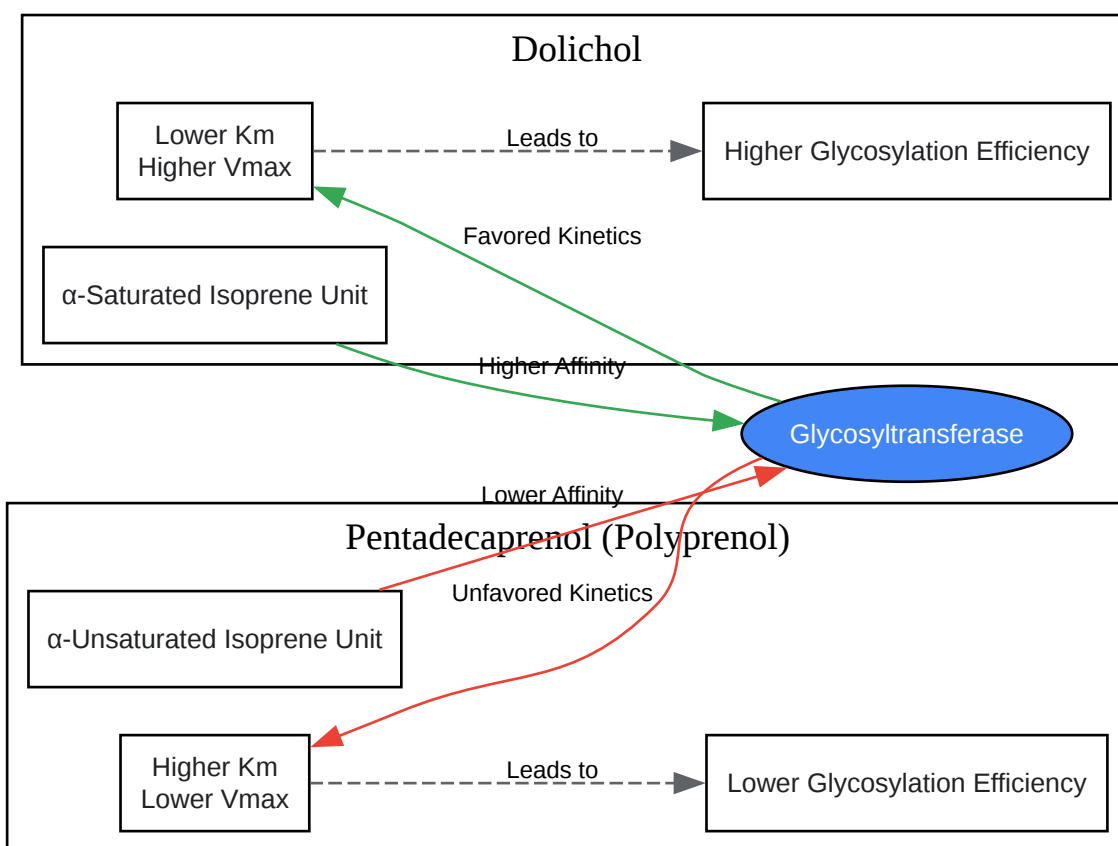

[Click to download full resolution via product page](#)

Caption: Dolichol vs. **Pentadecaprenol** Efficiency.

Need Custom Synthesis?

BenchChem offers custom synthesis for rare earth carbides and specific isotopic labeling.

Email: info@benchchem.com or [Request Quote Online](#).

References

- 1. Mammalian glycosyltransferases prefer glycosyl phosphoryl dolichols rather than glycosyl phosphoryl polyprenols as substrates for oligosaccharyl synthesis - PubMed [pubmed.ncbi.nlm.nih.gov]
- To cite this document: BenchChem. [Pentadecaprenol vs. Dolichol: A Comparative Guide to Glycosylation Efficiency]. BenchChem, [2025]. [Online PDF]. Available at:

[<https://www.benchchem.com/product/b15548959#comparing-pentadecaprenol-and-dolichol-in-glycosylation-efficiency>]

Disclaimer & Data Validity:

The information provided in this document is for Research Use Only (RUO) and is strictly not intended for diagnostic or therapeutic procedures. While BenchChem strives to provide accurate protocols, we make no warranties, express or implied, regarding the fitness of this product for every specific experimental setup.

Technical Support: The protocols provided are for reference purposes. Unsure if this reagent suits your experiment? [[Contact our Ph.D. Support Team for a compatibility check](#)]

Need Industrial/Bulk Grade? [Request Custom Synthesis Quote](#)

BenchChem

Our mission is to be the trusted global source of essential and advanced chemicals, empowering scientists and researchers to drive progress in science and industry.

Contact

Address: 3281 E Guasti Rd
Ontario, CA 91761, United States
Phone: (601) 213-4426
Email: info@benchchem.com