

# Application Note: Using Peptide K to Stimulate T-cells In Vitro

**Author:** BenchChem Technical Support Team. **Date:** April 2026

## Compound of Interest

Compound Name: Peptide K

Cat. No.: B15547009

[Get Quote](#)

For Research Use Only. Not for use in diagnostic procedures.

## Introduction

T-cell activation is a critical event in the adaptive immune response, initiated by the interaction of the T-cell receptor (TCR) with a specific peptide-major histocompatibility complex (pMHC) on an antigen-presenting cell (APC).[1][2][3] In vitro stimulation of T-cells with specific peptides is a fundamental technique in immunology research, enabling the study of T-cell signaling, effector functions, and the development of immunotherapies.[4][5] This application note provides a detailed protocol for the in vitro stimulation of human T-cells using **Peptide K**, a synthetic peptide designed to elicit an antigen-specific T-cell response. The protocol covers T-cell isolation, stimulation, and downstream analysis of activation markers and cytokine production.

## Principle of the Method

**Peptide K**, when presented by APCs, is recognized by specific CD4+ or CD8+ T-cells, leading to their activation, proliferation, and differentiation into effector cells. Activated T-cells upregulate surface markers such as CD25 and CD69 and secrete cytokines like Interferon-gamma (IFN- $\gamma$ ) and Tumor Necrosis Factor-alpha (TNF- $\alpha$ ).[6][7] This protocol utilizes peripheral

blood mononuclear cells (PBMCs) as a source of both T-cells and APCs. The activation of antigen-specific T-cells is quantified by measuring cytokine production via Enzyme-Linked Immunosorbent Spot (ELISpot) and intracellular cytokine staining (ICS) followed by flow cytometry.[6][8]

## Materials and Methods

### Reagents and Materials

- Human Peripheral Blood Mononuclear Cells (PBMCs)
- **Peptide K**
- RPMI 1640 medium
- Fetal Bovine Serum (FBS)
- Penicillin-Streptomycin solution
- Phosphate-Buffered Saline (PBS)
- DMSO (for peptide reconstitution)
- Human IFN- $\gamma$  ELISpot kit
- Human TNF- $\alpha$  ELISpot kit
- Flow cytometry antibodies: Anti-Human CD3, CD4, CD8, CD25, CD69, IFN- $\gamma$ , TNF- $\alpha$
- Brefeldin A
- Phorbol 12-myristate 13-acetate (PMA) and Ionomycin (Positive Control)
- Cell viability dye

### Equipment

- Cell culture plates (96-well and 24-well)

- Centrifuge
- Incubator (37°C, 5% CO<sub>2</sub>)
- Flow cytometer
- ELISpot reader
- Pipettes and tips
- Biosafety cabinet

## Experimental Protocols

### Protocol 1: Preparation of Peptide K and PBMCs

- **Peptide K Reconstitution:** Reconstitute lyophilized **Peptide K** in sterile DMSO to create a stock solution of 1 mg/mL. Further dilute in cell culture medium to the desired working concentrations. The final DMSO concentration in the cell culture should not exceed 1% (v/v) to avoid toxicity.[6]
- **PBMC Isolation:** Isolate PBMCs from whole blood using Ficoll-Paque density gradient centrifugation.
- **Cell Counting and Viability:** Wash the isolated PBMCs with PBS and resuspend in complete RPMI 1640 medium (supplemented with 10% FBS and 1% Penicillin-Streptomycin). Determine cell concentration and viability using a hemocytometer and trypan blue exclusion or an automated cell counter.

### Protocol 2: In Vitro T-cell Stimulation for ELISpot Assay

- Pre-wet the ELISpot plate with 35% ethanol, wash with sterile PBS, and coat with capture antibody overnight at 4°C.
- Wash the plate and block with RPMI 1640 medium containing 10% FBS for at least 1 hour at room temperature.
- Seed  $2.5 \times 10^5$  PBMCs per well.[6]

- Add **Peptide K** to the wells at various concentrations (e.g., 1, 5, 10 µg/mL).
- Include a negative control (medium with DMSO vehicle) and a positive control (PMA/Ionomycin).
- Incubate the plate at 37°C with 5% CO<sub>2</sub> for 18-24 hours.
- Wash the plate and add the biotinylated detection antibody.
- Incubate, wash, and add streptavidin-HRP.
- Develop the spots with the substrate solution and count the spots using an ELISpot reader. Each spot represents a single cytokine-secreting cell.[6]

### Protocol 3: In Vitro T-cell Stimulation for Flow Cytometry

- Seed  $1 \times 10^6$  PBMCs per well in a 24-well plate.
- Add **Peptide K** at the desired concentration (e.g., 10 µg/mL).
- Include negative and positive controls as in the ELISpot assay.
- Incubate at 37°C with 5% CO<sub>2</sub> for 6 hours.
- Add Brefeldin A during the last 4 hours of incubation to block cytokine secretion.[6]
- Harvest the cells and wash with PBS.
- Stain for cell viability and surface markers (CD3, CD4, CD8, CD25, CD69) for 30 minutes on ice.
- Fix and permeabilize the cells using a commercial kit.
- Stain for intracellular cytokines (IFN-γ, TNF-α) for 30 minutes at room temperature.
- Wash the cells and acquire data on a flow cytometer.

### Data Presentation

The following tables summarize expected quantitative data from T-cell stimulation experiments with **Peptide K**.

 Table 1: IFN- $\gamma$  and TNF- $\alpha$  Production Measured by ELISpot

Treatment	Peptide K Concentration ( $\mu\text{g/mL}$ )	IFN- $\gamma$ Spot Forming Units (SFU) / $10^6$ PBMCs	TNF- $\alpha$ Spot Forming Units (SFU) / $10^6$ PBMCs
Negative Control	0	$5 \pm 2$	$3 \pm 1$
Peptide K	1	$50 \pm 8$	$45 \pm 6$
Peptide K	5	$150 \pm 15$	$130 \pm 12$
Peptide K	10	$250 \pm 20$	$220 \pm 18$
Positive Control	PMA/Ionomycin	$1500 \pm 100$	$1300 \pm 90$

Table 2: T-cell Activation Markers and Intracellular Cytokines by Flow Cytometry

T-cell Subset	Treatment	% CD25+	% CD69+	% IFN- $\gamma$ +	% TNF- $\alpha$ +
CD4+ T-cells	Negative Control	$2.1 \pm 0.5$	$1.5 \pm 0.3$	$0.1 \pm 0.05$	$0.2 \pm 0.08$
Peptide K (10 $\mu\text{g/mL}$ )	$15.3 \pm 2.1$	$20.8 \pm 2.5$	$5.2 \pm 0.7$	$4.8 \pm 0.6$	
CD8+ T-cells	Negative Control	$1.8 \pm 0.4$	$1.2 \pm 0.2$	$0.2 \pm 0.07$	$0.3 \pm 0.09$
Peptide K (10 $\mu\text{g/mL}$ )	$25.6 \pm 3.2$	$30.1 \pm 3.5$	$8.9 \pm 1.1$	$7.5 \pm 0.9$	

## Visualizations

### T-cell Activation Signaling Pathway

The following diagram illustrates the general signaling cascade initiated by TCR engagement with a peptide-MHC complex.

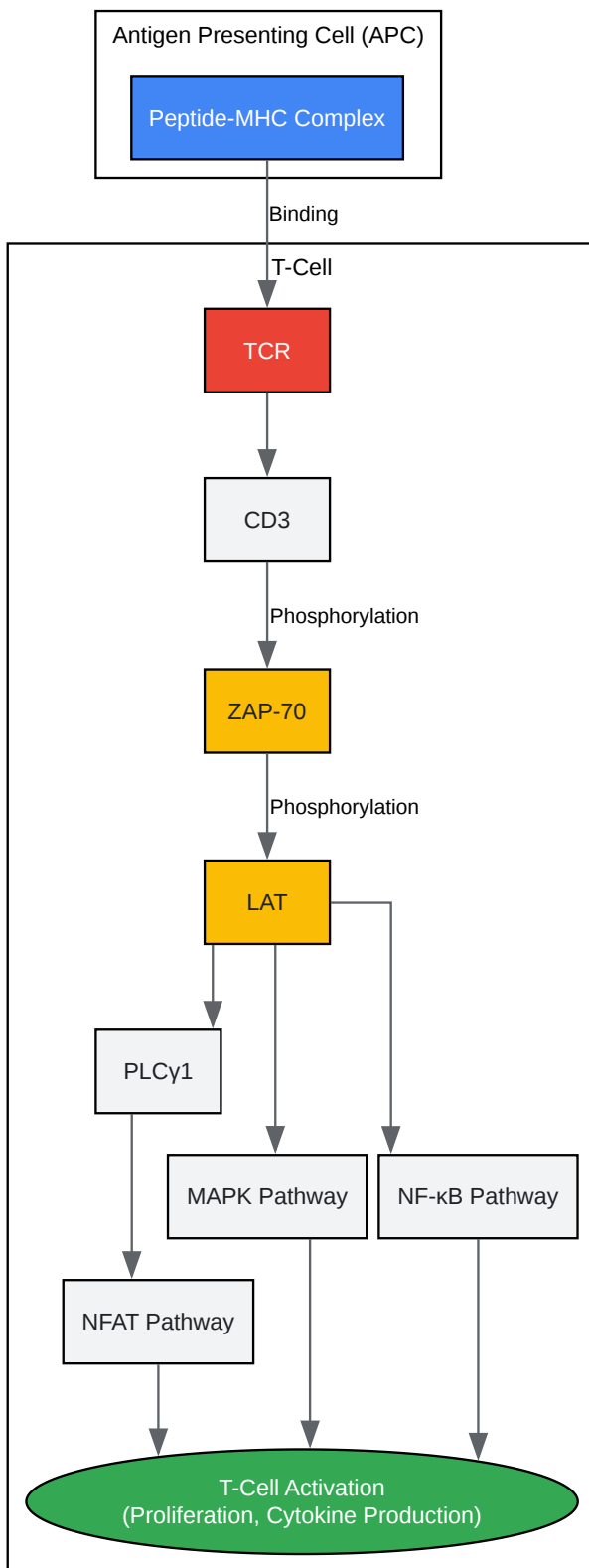

[Click to download full resolution via product page](#)

*Simplified T-cell activation signaling cascade.*

## Experimental Workflow for T-cell Stimulation

The diagram below outlines the key steps in the in vitro T-cell stimulation and analysis workflow.

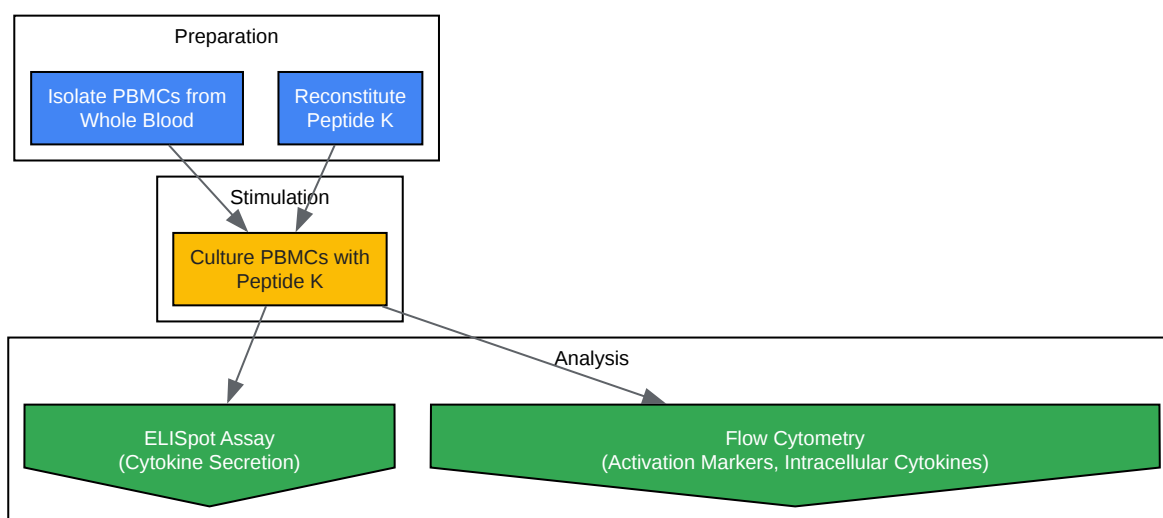

[Click to download full resolution via product page](#)

*Workflow for in vitro T-cell stimulation and analysis.*

## Troubleshooting

Issue	Possible Cause	Solution
Low/No T-cell response	Suboptimal peptide concentration	Titrate Peptide K concentration.
Poor PBMC viability	Use freshly isolated, healthy PBMCs.	
Incorrect incubation time	Optimize incubation time for your specific assay.	
High background in negative control	Contamination	Maintain sterile technique.
Non-specific stimulation	Ensure reagents are free of endotoxins.	
High variability between replicates	Pipetting errors	Use calibrated pipettes and ensure proper mixing.
Uneven cell distribution	Gently resuspend cells before plating.	

## Conclusion

This application note provides a comprehensive protocol for the in vitro stimulation of T-cells using **Peptide K**. The described methods for ELISpot and flow cytometry allow for the robust quantification of antigen-specific T-cell responses. By following these protocols, researchers can effectively study the mechanisms of T-cell activation and evaluate the immunogenicity of specific peptides.

### Need Custom Synthesis?

BenchChem offers custom synthesis for rare earth carbides and specific isotopic labeling.

Email: [info@benchchem.com](mailto:info@benchchem.com) or [Request Quote Online](#).

## References

- 1. A role for “self” in T-cell activation - PMC [[pmc.ncbi.nlm.nih.gov](https://pubmed.ncbi.nlm.nih.gov/)]

- [2. m.youtube.com \[m.youtube.com\]](https://m.youtube.com)
- [3. ascopubs.org \[ascopubs.org\]](https://ascopubs.org)
- [4. In Vitro T Cell Assays - T Cell Assays - ICE Bioscience \[en.ice-biosci.com\]](https://en.ice-biosci.com)
- [5. viraxbiolabs.com \[viraxbiolabs.com\]](https://viraxbiolabs.com)
- [6. stemcell.com \[stemcell.com\]](https://stemcell.com)
- [7. In vitro assays for effector T cell functions and activity of immunomodulatory antibodies - PMC \[pmc.ncbi.nlm.nih.gov\]](https://pubmed.ncbi.nlm.nih.gov/)
- [8. files01.core.ac.uk \[files01.core.ac.uk\]](https://files01.core.ac.uk)
- To cite this document: BenchChem. [Application Note: Using Peptide K to Stimulate T-cells In Vitro]. BenchChem, [2026]. [Online PDF]. Available at: [\[https://www.benchchem.com/product/b15547009/docs#application-note-using-peptide-k-to-stimulate-t-cells-in-vitro\]](https://www.benchchem.com/product/b15547009/docs#application-note-using-peptide-k-to-stimulate-t-cells-in-vitro)

---

#### Disclaimer & Data Validity:

The information provided in this document is for Research Use Only (RUO) and is strictly not intended for diagnostic or therapeutic procedures. While BenchChem strives to provide accurate protocols, we make no warranties, express or implied, regarding the fitness of this product for every specific experimental setup.

**Technical Support:** The protocols provided are for reference purposes. Unsure if this reagent suits your experiment?

**Need Industrial/Bulk Grade?** [Request Custom Synthesis Quote](#)

## BenchChem

Our mission is to be the trusted global source of essential and advanced chemicals, empowering scientists and researchers to drive progress in science and industry.

#### Contact

Address: 3281 E Guasti Rd

Ontario, CA 91761, United States

Phone: (601) 213-4426

Email: [info@benchchem.com](mailto:info@benchchem.com)

Contact our Ph.D. Support Team for a compatibility check