

# A Researcher's Guide to the Efficiency of Bioorthogonal Labeling Techniques

**Author:** BenchChem Technical Support Team. **Date:** April 2026

## Compound of Interest

Compound Name: *DBCO-Tetraacetyl mannosamine*

Cat. No.: *B15547900*

[Get Quote](#)

In the intricate world of molecular biology and drug development, the ability to visualize and track biomolecules in their native environment is paramount. Bioorthogonal chemistry provides a powerful toolkit for this purpose, offering a suite of chemical reactions that can occur within living systems without interfering with innate biochemical processes.<sup>[1]</sup> For researchers, scientists, and drug development professionals, selecting the most appropriate bioorthogonal labeling technique is a critical decision that hinges on a variety of factors, with reaction efficiency being a primary consideration. This guide provides a comprehensive comparison of the leading bioorthogonal labeling techniques, supported by quantitative data and detailed experimental protocols.

Bioorthogonal reactions are characterized by their high selectivity, ability to form stable products in high yields, and capacity to proceed rapidly at low concentrations under physiological conditions.<sup>[1]</sup> The most widely utilized of these reactions include the Staudinger ligation, copper(I)-catalyzed azide-alkyne cycloaddition (CuAAC), strain-promoted azide-alkyne cycloaddition (SPAAC), and the inverse-electron-demand Diels-Alder (iEDDA) reaction, often referred to as tetrazine ligation.<sup>[1][2]</sup> Each of these methods presents a unique set of advantages and disadvantages, particularly concerning their reaction kinetics and biocompatibility.<sup>[1]</sup>

## Quantitative Comparison of Reaction Kinetics

The efficiency of a bioorthogonal reaction is best quantified by its second-order rate constant ( $k_2$ ), which reflects how quickly the reactants are converted into the final product. A higher  $k_2$  value indicates a faster reaction, a crucial attribute when dealing with low-abundance biomolecules or tracking dynamic biological processes.[3]

Bioorthogonal Reaction	Typical Second-Order Rate Constant ( $k_2$ ) [ $M^{-1}s^{-1}$ ]	Key Advantages	Key Disadvantages
Staudinger Ligation	$\sim 10^{-3}$	Highly biocompatible, azide is a small and inert reporter.[4][5]	Slow kinetics can lead to inefficient labeling.[4][5]
CuAAC	$\sim 10 - 100$	Fast reaction rates.[6]	Requires a copper catalyst, which can be toxic to living cells.[7][8]
SPAAC	$\sim 10^{-3} - 1$	No catalyst required, good biocompatibility.[6][9]	Generally slower than CuAAC and iEDDA; some strained alkynes can have off-target reactivity.[6][7]
iEDDA (Tetrazine Ligation)	$\sim 1 - 10^6$	Exceptionally fast kinetics, highly bioorthogonal.[3][10]	Some tetrazines can have limited stability in aqueous solutions.[4]

## Reaction Mechanisms and Experimental Workflows

To provide a clearer understanding of these techniques, the following diagrams illustrate their fundamental reaction mechanisms and a generalized experimental workflow for bioorthogonal labeling.

### Reaction Mechanisms

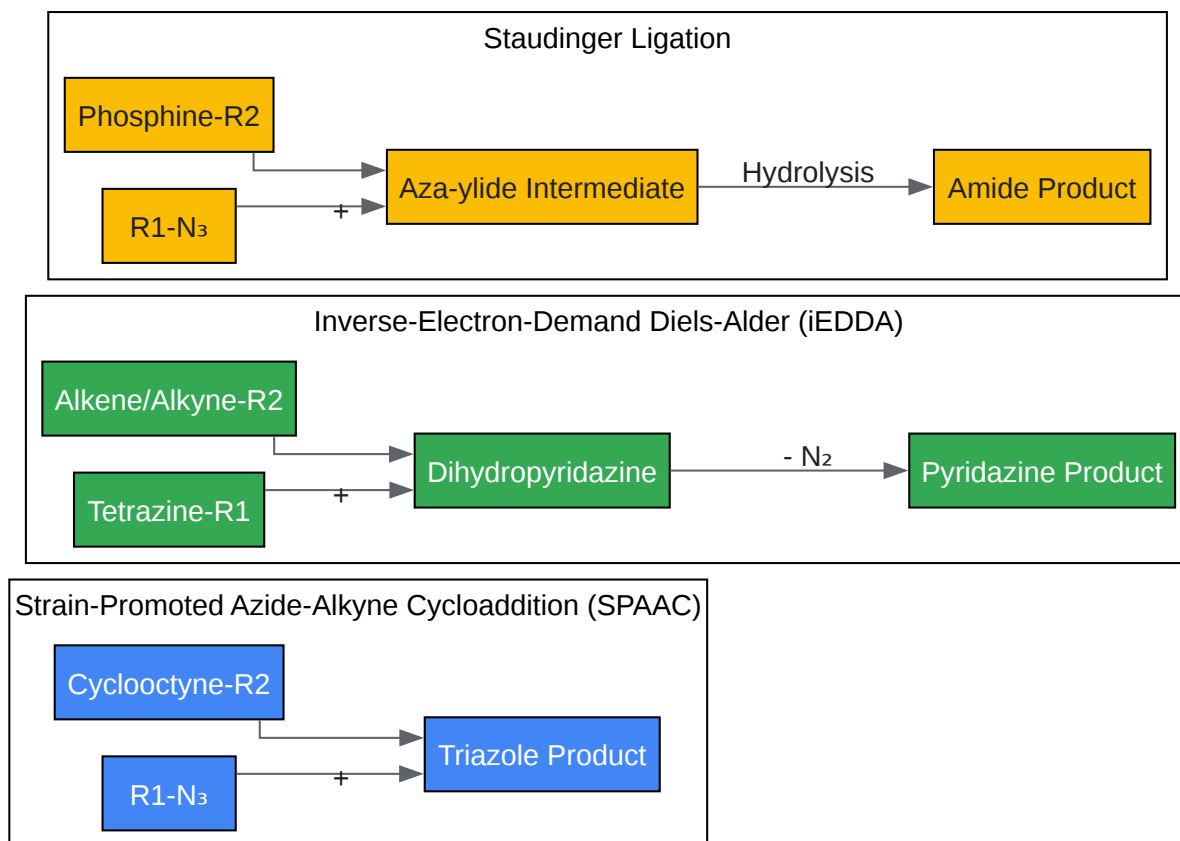

[Click to download full resolution via product page](#)

Reaction mechanisms of common bioorthogonal labeling techniques.

## Generalized Experimental Workflow

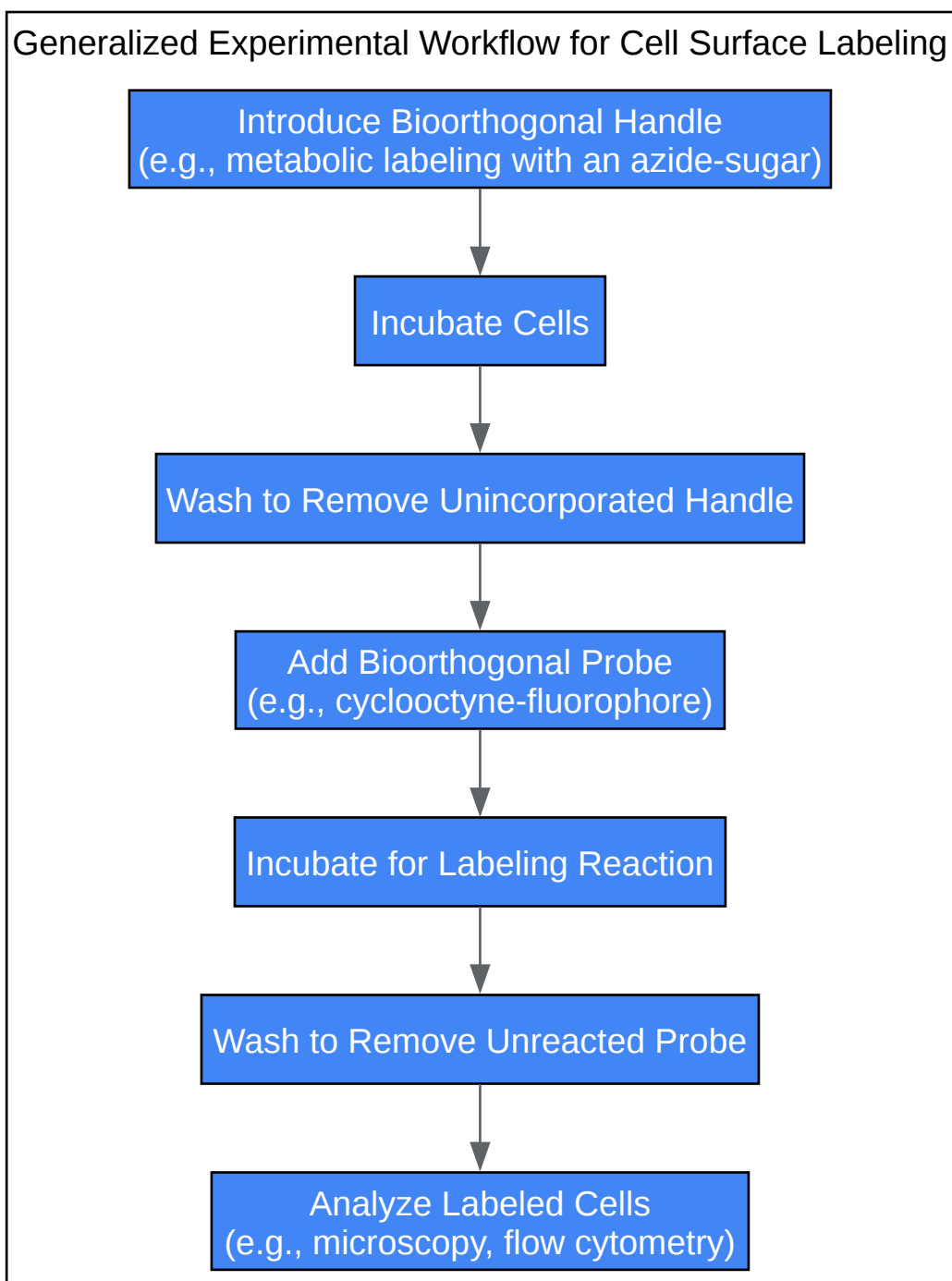

[Click to download full resolution via product page](#)

A typical workflow for a bioorthogonal labeling experiment.

# Detailed Experimental Protocol: Cell Surface Protein Labeling via iEDDA

This protocol provides a method for labeling cell surface proteins using a norbornene-modified antibody and a tetrazine-conjugated probe, a common application of the highly efficient iEDDA reaction.[\[11\]](#)

## Materials:

- Cells expressing the target cell surface protein
- Complete cell culture medium
- Phosphate-buffered saline (PBS)
- Blocking buffer (e.g., PBS with 1% BSA)
- Norbornene-modified antibody specific to the target protein
- Tetrazine-conjugated probe (e.g., tetrazine-fluorophore)
- DMSO (for dissolving the probe)

## Procedure:

- **Cell Preparation:** Culture cells to the desired confluency in a suitable format (e.g., multi-well plate, chamber slide).
- **Blocking:** Wash the cells once with PBS and then incubate with blocking buffer for 30 minutes at room temperature to minimize non-specific antibody binding.
- **Antibody Incubation:** Dilute the norbornene-modified antibody to its optimal concentration in blocking buffer. Remove the blocking buffer and add the diluted antibody solution to the cells. Incubate for 1 hour at 4°C or 37°C. Incubation at 4°C can help to minimize receptor internalization.[\[11\]](#)
- **Washing:** Wash the cells three times with PBS to remove any unbound antibody.

- **Probe Preparation:** Prepare a stock solution of the tetrazine-conjugated probe in DMSO. Immediately before use, dilute the probe to the desired final concentration (typically 1-50  $\mu\text{M}$ ) in serum-free cell culture medium or PBS.[\[11\]](#) Ensure the final DMSO concentration is low (e.g., <0.5%) to avoid cell toxicity.[\[11\]](#)
- **Labeling Reaction:** Add the diluted tetrazine-probe solution to the cells. Incubate for 15-60 minutes at room temperature or 37°C, protected from light if using a fluorescent probe.[\[11\]](#)
- **Final Washing:** Wash the cells three to five times with PBS to remove any unreacted tetrazine-probe.[\[11\]](#)
- **Analysis:** The cells are now ready for analysis by methods such as fluorescence microscopy or flow cytometry.

## Troubleshooting:

Issue	Possible Cause	Suggested Solution
Low or no signal	- Inefficient antibody binding- Low probe concentration- Short incubation time	- Optimize antibody concentration and incubation time- Increase probe concentration or incubation time- Ensure reagents are fresh and properly stored <a href="#">[11]</a>
High background	- Non-specific binding of antibody or probe- Incomplete washing	- Ensure blocking step is included- Increase the number and duration of wash steps- Titrate antibody and probe to the lowest effective concentration <a href="#">[11]</a>
Cell toxicity	- High concentration of the tetrazine-probe or solvent	- Perform a dose-response curve to determine the optimal, non-toxic probe concentration- Ensure the final solvent concentration is minimal <a href="#">[7]</a> <a href="#">[11]</a>

## Choosing the Right Technique

The selection of a bioorthogonal labeling technique is highly dependent on the specific experimental context.<sup>[1]</sup> For applications demanding rapid labeling, such as in vivo imaging with short-lived probes or tracking fast cellular processes, the exceptionally fast kinetics of tetrazine ligation make it the preferred method.<sup>[1][2]</sup> SPAAC offers a good balance of biocompatibility and reactivity for many live-cell imaging applications, eliminating the concern of copper-induced toxicity associated with CuAAC.<sup>[7][9]</sup> While the Staudinger ligation has the slowest kinetics, its high biocompatibility and the small size of the azide reporter group can be advantageous in certain contexts where minimal perturbation to the biological system is critical.<sup>[4]</sup> As the field of bioorthogonal chemistry continues to evolve, researchers are presented with an expanding array of powerful tools to unravel the complexities of biology.<sup>[2][12]</sup>

### *Need Custom Synthesis?*

*BenchChem offers custom synthesis for rare earth carbides and specific isotopic labeling.*

*Email: [info@benchchem.com](mailto:info@benchchem.com) or [Request Quote Online](#).*

## References

- [1. benchchem.com \[benchchem.com\]](#)
- [2. eurjchem.com \[eurjchem.com\]](#)
- [3. benchchem.com \[benchchem.com\]](#)
- [4. pubs.acs.org \[pubs.acs.org\]](#)
- [5. pubs.acs.org \[pubs.acs.org\]](#)
- [6. IEDDA: An Attractive Bioorthogonal Reaction for Biomedical Applications - PMC \[pmc.ncbi.nlm.nih.gov\]](#)
- [7. benchchem.com \[benchchem.com\]](#)
- [8. Bioorthogonal chemistry - Wikipedia \[en.wikipedia.org\]](#)
- [9. Designing Bioorthogonal Reactions for Biomedical Applications - PMC \[pmc.ncbi.nlm.nih.gov\]](#)
- [10. researchgate.net \[researchgate.net\]](#)
- [11. benchchem.com \[benchchem.com\]](#)

- [12. Cutting-edge bioorthogonal chemistry: Innovations, practical applications, and emerging trends | European Journal of Chemistry \[eurjchem.com\]](#)
- To cite this document: BenchChem. [A Researcher's Guide to the Efficiency of Bioorthogonal Labeling Techniques]. BenchChem, [2026]. [Online PDF]. Available at: [<https://www.benchchem.com/product/b15547900/docs#a-researcher-s-guide-to-the-efficiency-of-bioorthogonal-labeling-techniques>]

---

### Disclaimer & Data Validity:

The information provided in this document is for Research Use Only (RUO) and is strictly not intended for diagnostic or therapeutic procedures. While BenchChem strives to provide accurate protocols, we make no warranties, express or implied, regarding the fitness of this product for every specific experimental setup.

**Technical Support:** The protocols provided are for reference purposes. Unsure if this reagent suits your experiment?

**Need Industrial/Bulk Grade?** [Request Custom Synthesis Quote](#)

## BenchChem

Our mission is to be the trusted global source of essential and advanced chemicals, empowering scientists and researchers to drive progress in science and industry.

### Contact

Address: 3281 E Guasti Rd  
Ontario, CA 91761, United States  
Phone: (601) 213-4426  
Email: [info@benchchem.com](mailto:info@benchchem.com)

[Contact our Ph.D. Support Team for a compatibility check](#)