

Technical Support Center: Quantification of Low-Abundance 25-Methyhexacosanoyl-CoA

Author: BenchChem Technical Support Team. **Date:** December 2025

Compound of Interest

Compound Name: 25-methyhexacosanoyl-CoA

Cat. No.: B15545029

[Get Quote](#)

This technical support center provides troubleshooting guidance and frequently asked questions (FAQs) for researchers, scientists, and drug development professionals working on the quantification of low-abundance **25-methyhexacosanoyl-CoA** and other very-long-chain fatty acyl-CoAs (VLCFA-CoAs).

Frequently Asked Questions (FAQs)

Q1: What is the most sensitive and specific method for quantifying low-abundance **25-methyhexacosanoyl-CoA**?

A1: Liquid chromatography coupled with tandem mass spectrometry (LC-MS/MS) is the most widely accepted method for the sensitive and selective quantification of acyl-CoAs, including **25-methyhexacosanoyl-CoA**.^{[1][2][3]} This technique provides high specificity through methods like multiple reaction monitoring (MRM), which tracks specific precursor-to-product ion transitions for each acyl-CoA species.^{[4][5]}

Q2: Why are my **25-methyhexacosanoyl-CoA** samples degrading, and how can I prevent this?

A2: Acyl-CoAs are inherently unstable and susceptible to hydrolysis, especially in alkaline or strongly acidic aqueous solutions. To minimize degradation, it is crucial to process samples quickly on ice and store them at -80°C, preferably as a dry pellet. For reconstitution before analysis, using a buffered solution such as 50 mM ammonium acetate at a neutral pH or

resuspending in a methanol-water mixture can enhance stability compared to unbuffered aqueous solutions.[4]

Q3: What are the characteristic fragmentation patterns for **25-methyhexacosanoyl-CoA** and other VLCFA-CoAs in positive ion mode MS/MS?

A3: In positive ion mode, acyl-CoAs exhibit a common and predictable fragmentation pattern. This is characterized by a neutral loss of the 3'-phospho-ADP moiety, which corresponds to a mass difference of 507 Da.[6] This allows for the use of neutral loss scans to identify a broad range of acyl-CoA species within a sample. Another frequently observed fragment ion is at m/z 428, which results from cleavage between the 5' diphosphates.[4][6]

Q4: How can I improve the chromatographic separation of very-long-chain acyl-CoAs?

A4: Achieving good chromatographic separation is critical to minimize ion suppression and ensure accurate quantification. For VLCFA-CoAs, reversed-phase chromatography, typically with a C18 or C8 column, is commonly used.[1] Using ion-pairing agents or operating at a high pH (e.g., pH 10.5 with ammonium hydroxide) can significantly improve peak shape and resolution for these amphiphilic molecules.[1][2]

Q5: What are suitable internal standards for the quantification of **25-methyhexacosanoyl-CoA**?

A5: The ideal internal standard is a stable isotope-labeled version of the analyte (e.g., ^{13}C -labeled **25-methyhexacosanoyl-CoA**). However, these are often not commercially available. A practical alternative is to use an odd-chain very-long-chain fatty acyl-CoA that is not endogenously present in the sample, such as C23:0-CoA or C25:0-CoA.[1] This helps to account for variability in extraction efficiency and matrix effects.

Troubleshooting Guides

This section addresses specific issues that may arise during the quantification of **25-methyhexacosanoyl-CoA**.

Issue 1: Low or No Signal Detected

Possible Cause	Troubleshooting Steps
Analyte Degradation	<ul style="list-style-type: none">- Ensure all sample preparation steps are performed on ice or at 4°C.- Minimize the time samples spend in aqueous solutions.- Store extracted samples as dry pellets at -80°C until analysis.[4]
Poor Extraction Recovery	<ul style="list-style-type: none">- Optimize the extraction solvent. An 80% methanol solution has been shown to be effective for a broad range of acyl-CoAs.- For tissue samples, ensure complete homogenization.- Consider solid-phase extraction (SPE) with a mixed-mode or C18 cartridge to enrich for acyl-CoAs, but be aware that this can lead to loss of more hydrophilic species.
Ion Suppression	<ul style="list-style-type: none">- Improve chromatographic separation to resolve 25-methylhexacosanoyl-CoA from co-eluting matrix components.- Dilute the sample extract to reduce the concentration of interfering species.- Utilize a stable isotope-labeled internal standard if available to compensate for matrix effects.
Adsorption to Surfaces	<ul style="list-style-type: none">- The phosphate groups of acyl-CoAs can adhere to glass and metal surfaces. Using glass vials instead of plastic and adding additives to the reconstitution solvent can help minimize signal loss.[7]

Issue 2: High Variability Between Replicates

Possible Cause	Troubleshooting Steps
Inconsistent Sample Preparation	<ul style="list-style-type: none">- Ensure precise and consistent volumes are used for all reagents and solvents.- Standardize homogenization and extraction times for all samples.- Use a reliable internal standard added at the very beginning of the sample preparation process to account for extraction variability.^[1]
Sample Inhomogeneity	<ul style="list-style-type: none">- For tissue samples, ensure the portion taken for analysis is representative of the whole sample.- For cell pellets, ensure complete and consistent lysis.
LC-MS/MS System Instability	<ul style="list-style-type: none">- Equilibrate the LC column thoroughly before starting the analytical run.- Monitor system suitability by injecting a standard solution at regular intervals throughout the sample sequence.

Issue 3: Inaccurate or Imprecise Quantification

Possible Cause	Troubleshooting Steps
Poor Chromatographic Peak Shape	<ul style="list-style-type: none">- Optimize the mobile phase composition. The use of high pH with ammonium hydroxide can improve peak shape for acyl-CoAs.[2] - Consider a column with a different chemistry (e.g., C8 instead of C18).
Non-Linearity of Calibration Curve	<ul style="list-style-type: none">- Construct calibration curves using a matrix that closely matches the study samples to account for matrix effects. - Use a weighted linear regression (e.g., 1/x) for calibration curves to improve accuracy at lower concentrations.
Lack of a Suitable Internal Standard	<ul style="list-style-type: none">- If a stable isotope-labeled standard is unavailable, use an odd-chain acyl-CoA that has a similar chain length and chemical properties to 25-methyhexacosanoyl-CoA.[1]

Quantitative Data

Due to the extremely low abundance of **25-methyhexacosanoyl-CoA**, specific quantitative data in the public domain is scarce. The following table presents representative concentrations of other very-long-chain acyl-CoAs in cultured cells to provide a general understanding of the expected concentration range.

Table 1: Representative Concentrations of Very-Long-Chain Acyl-CoAs in Cultured Mammalian Cells

Acyl-CoA Species	Cell Type	Concentration (pmol/10 ⁶ cells)
C22:0-CoA	RAW264.7	~ 0.1 - 0.5
C24:0-CoA	RAW264.7	~ 0.2 - 1.0
C26:0-CoA	RAW264.7	~ 0.1 - 0.4
C24:0-CoA	MCF7	~ 0.05 - 0.2
C26:0-CoA	MCF7	~ 0.02 - 0.1

Data is illustrative and compiled from trends reported in the literature. Actual concentrations can vary significantly based on cell type, culture conditions, and analytical methodology.

Experimental Protocols

Protocol 1: Extraction of VLCFA-CoAs from Cultured Cells

- **Cell Harvesting:** a. Aspirate the culture medium and wash the cells once with ice-cold phosphate-buffered saline (PBS). b. Scrape the cells in a minimal volume of ice-cold PBS and transfer to a microcentrifuge tube. c. Centrifuge at 1,000 x g for 5 minutes at 4°C.
- **Lysis and Deproteinization:** a. Aspirate the supernatant and add 300 µL of ice-cold deionized water containing 0.6% formic acid to the cell pellet. b. Add the internal standard (e.g., C25:0-CoA) to each sample. c. Resuspend the cell pellet and add 270 µL of acetonitrile. d. Vortex vigorously and/or sonicate to ensure homogeneity.
- **Extraction:** a. Centrifuge at 16,000 x g for 10 minutes at 4°C to pellet the protein precipitate. b. Carefully transfer the supernatant to a new tube.
- **Sample Concentration:** a. Dry the supernatant under a stream of nitrogen gas. b. Store the dried extract at -80°C until LC-MS/MS analysis. c. Reconstitute the sample in a suitable

solvent (e.g., 50% methanol with 10 mM ammonium acetate) prior to injection.

Protocol 2: General LC-MS/MS Method for VLCFA-CoAs

- Liquid Chromatography:
 - Column: Reversed-phase C18 or C8 column (e.g., 2.1 x 150 mm, 1.7 μ m).
 - Mobile Phase A: 15 mM ammonium hydroxide in water (pH ~10.5).
 - Mobile Phase B: 15 mM ammonium hydroxide in acetonitrile.
 - Flow Rate: 0.4 mL/min.
 - Gradient: Start at 20% B, increase to 95% B over 10 minutes, hold for 2 minutes, then return to initial conditions.
- Mass Spectrometry (Tandem Quadrupole):
 - Ionization Mode: Positive Electrospray Ionization (ESI+).
 - Scan Type: Multiple Reaction Monitoring (MRM).
 - Precursor Ion $[M+H]^+$: Calculate the mass of **25-methyhexacosanoyl-CoA** + H^+ .
 - Product Ions: Monitor the transition to the fragment resulting from the neutral loss of 507 Da, and optionally the fragment at m/z 428.
 - Collision Energy: Optimize for the specific instrument and analyte.

Visualizations

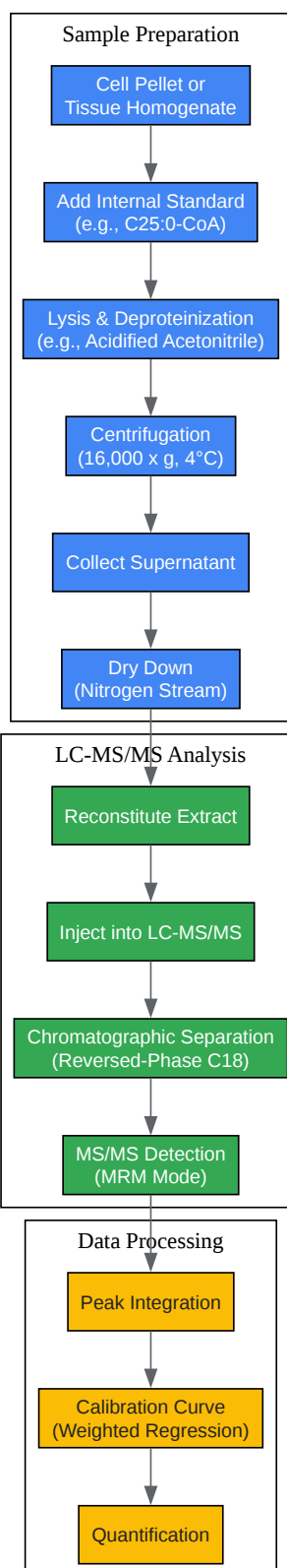

[Click to download full resolution via product page](#)

Caption: Experimental workflow for quantifying **25-methyhexacosanoyl-CoA**.

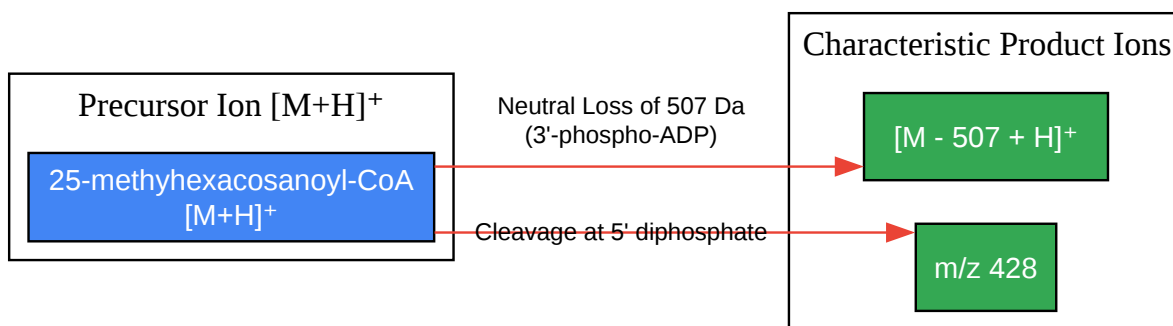

[Click to download full resolution via product page](#)

Caption: Characteristic MS/MS fragmentation of Acyl-CoAs.

Need Custom Synthesis?

BenchChem offers custom synthesis for rare earth carbides and specific isotopic labeling.

Email: info@benchchem.com or [Request Quote Online](#).

References

1. Quantitation of fatty acyl-coenzyme As in mammalian cells by liquid chromatography-electrospray ionization tandem mass spectrometry - PMC [pmc.ncbi.nlm.nih.gov]
2. Comprehensive quantitative analysis of fatty-acyl-Coenzyme A species in biological samples by ultra-high performance liquid chromatography-tandem mass spectrometry harmonizing hydrophilic interaction and reversed phase chromatography - PubMed [pubmed.ncbi.nlm.nih.gov]
3. A Single LC-MS/MS Analysis to Quantify CoA Biosynthetic Intermediates and Short-Chain Acyl CoAs - PubMed [pubmed.ncbi.nlm.nih.gov]
4. researchgate.net [researchgate.net]
5. researchgate.net [researchgate.net]
6. A Single LC-MS/MS Analysis to Quantify CoA Biosynthetic Intermediates and Short-Chain Acyl CoAs - PMC [pmc.ncbi.nlm.nih.gov]
7. medchemexpress.com [medchemexpress.com]

- To cite this document: BenchChem. [Technical Support Center: Quantification of Low-Abundance 25-Methyhexacosanoyl-CoA]. BenchChem, [2025]. [Online PDF]. Available at: [<https://www.benchchem.com/product/b15545029#challenges-in-quantifying-low-abundance-25-methyhexacosanoyl-coa>]

Disclaimer & Data Validity:

The information provided in this document is for Research Use Only (RUO) and is strictly not intended for diagnostic or therapeutic procedures. While BenchChem strives to provide accurate protocols, we make no warranties, express or implied, regarding the fitness of this product for every specific experimental setup.

Technical Support: The protocols provided are for reference purposes. Unsure if this reagent suits your experiment? [[Contact our Ph.D. Support Team for a compatibility check](#)]

Need Industrial/Bulk Grade? [Request Custom Synthesis Quote](#)

BenchChem

Our mission is to be the trusted global source of essential and advanced chemicals, empowering scientists and researchers to drive progress in science and industry.

Contact

Address: 3281 E Guasti Rd

Ontario, CA 91761, United States

Phone: (601) 213-4426

Email: info@benchchem.com