

Investigating the Anti-Cancer Activity of SKL2001: A Technical Guide

Author: BenchChem Technical Support Team. **Date:** April 2026

Compound of Interest

Compound Name: SKL2001
Cat. No.: B15545171

[Get Quote](#)

For Researchers, Scientists, and Drug Development Professionals

Abstract

SKL2001 is a small molecule compound identified as a potent agonist of the Wnt/ β -catenin signaling pathway. While aberrant activation of this pathway is commonly implicated in tumorigenesis, **SKL2001** exhibits a paradoxical anti-cancer activity in specific contexts, particularly in three-dimensional (3D) cancer models. This technical guide provides an in-depth overview of the anti-cancer properties of **SKL2001**, focusing on its mechanism of action, experimental data, and detailed protocols for its investigation. The information presented herein is intended to facilitate further research into the therapeutic potential of modulating the Wnt/ β -catenin pathway with **SKL2001**.

Introduction

The Wnt/ β -catenin signaling pathway plays a crucial role in embryonic development and adult tissue homeostasis. Its dysregulation is a hallmark of numerous cancers, most notably colorectal cancer. The central event in this pathway is the stabilization and nuclear translocation of β -catenin, which then acts as a transcriptional co-activator of target genes involved in cell proliferation, differentiation, and survival.

SKL2001 was discovered through high-throughput screening as a chemical activator of the Wnt/ β -catenin pathway.[1] Its primary mechanism of action involves the disruption of the Axin/ β -catenin interaction, a critical step in the formation of the β -catenin destruction complex.[1][2] This disruption prevents the phosphorylation and subsequent proteasomal degradation of β -catenin, leading to its accumulation and the activation of downstream signaling.[1][3]

Despite its role as a Wnt agonist, studies have revealed that **SKL2001** can suppress the growth of colon cancer spheroids.[4][5][6] This finding suggests a complex, context-dependent role for Wnt/ β -catenin signaling in cancer progression and highlights **SKL2001** as a valuable tool for dissecting these intricacies.

Mechanism of Action

SKL2001's primary molecular target is the protein-protein interaction between Axin and β -catenin. By binding to β -catenin, **SKL2001** sterically hinders its association with Axin, a scaffold protein essential for the β -catenin destruction complex.[2] This complex, which also includes adenomatous polyposis coli (APC), glycogen synthase kinase 3 β (GSK-3 β), and casein kinase 1 α (CK1 α), is responsible for phosphorylating β -catenin, marking it for ubiquitination and degradation.

The key effects of **SKL2001** on the Wnt/ β -catenin signaling pathway are:

- Disruption of the Axin/ β -catenin interaction.[2]
- Inhibition of β -catenin phosphorylation at residues Ser33, Ser37, Thr41, and Ser45.[1][3]
- Stabilization and accumulation of intracellular β -catenin.[5]
- Nuclear translocation of β -catenin and activation of TCF/LEF-mediated transcription.[5]

In the context of colon cancer spheroids, the activation of Wnt/ β -catenin signaling by **SKL2001** leads to an unexpected anti-proliferative effect. This is associated with the upregulation of E-cadherin expression and the induction of cell cycle arrest in the G0/G1 phase, with a concomitant reduction in c-myc levels.[4]

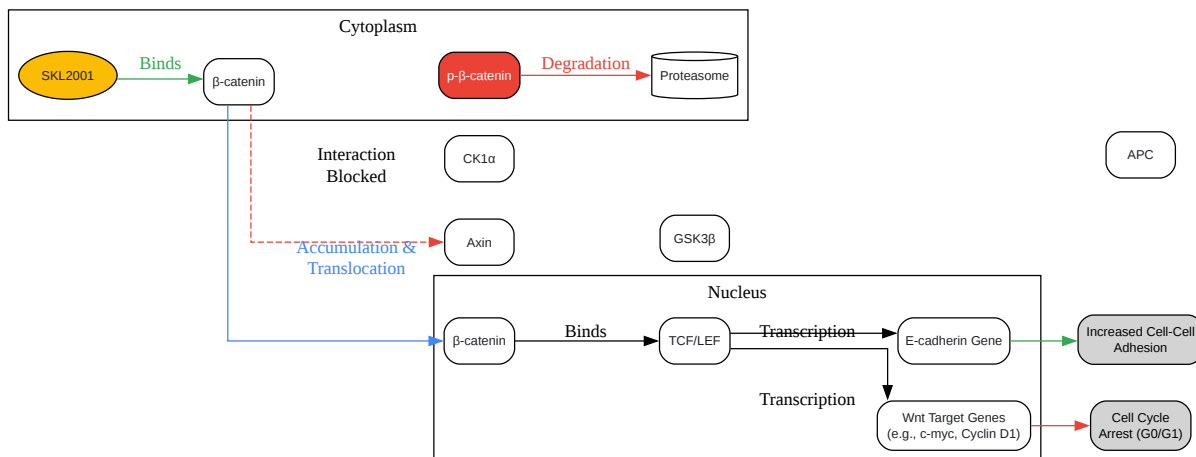

[Click to download full resolution via product page](#)

Caption: Mechanism of **SKL2001** Action.

Quantitative Data

While comprehensive quantitative data for **SKL2001** across a wide range of cancer cell lines is not readily available in the public domain, the following tables summarize the reported effects in specific experimental contexts.

Table 1: Effect of **SKL2001** on HCT116 Colon Cancer Spheroids

Parameter	Concentration	Observation	Reference
Proliferation	40 μ M	Significant inhibition of spheroid growth	[4][5]
Cell Cycle	40 μ M	Accumulation of cells in the G0/G1 phase	[4]
Protein Expression	40 μ M	Upregulation of E-cadherin	[4][5]
Protein Expression	40 μ M	Reduction of c-myc levels	[4]

 Table 2: Effect of **SKL2001** on Wnt/ β -catenin Signaling

Cell Line	Concentration	Effect	Reference
HEK293 reporter cells	10 and 30 μ M	Inhibition of β -catenin phosphorylation	[1]
Gastric Cancer (BGC-823)	40 μ M	Enhanced expression of Cyclin D1, c-Myc, and nuclear β -catenin	[5]
3T3-L1 preadipocytes	5, 10, and 30 μ M	Stabilization of intracellular β -catenin	[5]

Experimental Protocols

This section provides detailed methodologies for key experiments used to investigate the anti-cancer activity of **SKL2001**.

3D Spheroid Culture of HCT116 Cells

This protocol is adapted from spheroid formation assays used for colorectal cancer cell lines.[3][7][8][9]

Materials:

- HCT116 human colorectal carcinoma cell line (ATCC® CCL-247™)
- McCoy's 5a Medium (e.g., GIBCO #16600)
- Fetal Bovine Serum (FBS)
- Penicillin-Streptomycin
- PBS (Phosphate-Buffered Saline)
- Trypsin-EDTA
- Corning® Spheroid Microplates (e.g., 96-well) or other ultra-low attachment plates
- **SKL2001** (dissolved in DMSO)

Procedure:

- Culture HCT116 cells in McCoy's 5a medium supplemented with 10% FBS and 1% penicillin-streptomycin in a 37°C, 5% CO₂ incubator.
- Harvest cells at 70-90% confluency using Trypsin-EDTA.
- Neutralize trypsin with complete growth medium and centrifuge the cell suspension.
- Resuspend the cell pellet in fresh growth medium and perform a cell count.
- Seed a specific number of cells (e.g., 1,000 to 5,000 cells/well) in 100 µL of growth medium into each well of a 96-well spheroid microplate.
- Centrifuge the plate at a low speed (e.g., 200 x g) for 5 minutes to facilitate cell aggregation at the bottom of the well.
- Incubate the plate at 37°C and 5% CO₂. Spheroid formation should be observable within 24-72 hours.
- For drug treatment, prepare serial dilutions of **SKL2001** in growth medium. Add the desired final concentrations to the wells containing spheroids. Include a vehicle control (DMSO).

- Monitor spheroid growth over time (e.g., daily for 7 days) by capturing images using an inverted microscope.
- Spheroid size can be quantified using image analysis software (e.g., ImageJ) by measuring the diameter or area.
- Cell viability within the spheroids can be assessed using assays like the CellTiter-Glo® 3D Cell Viability Assay.

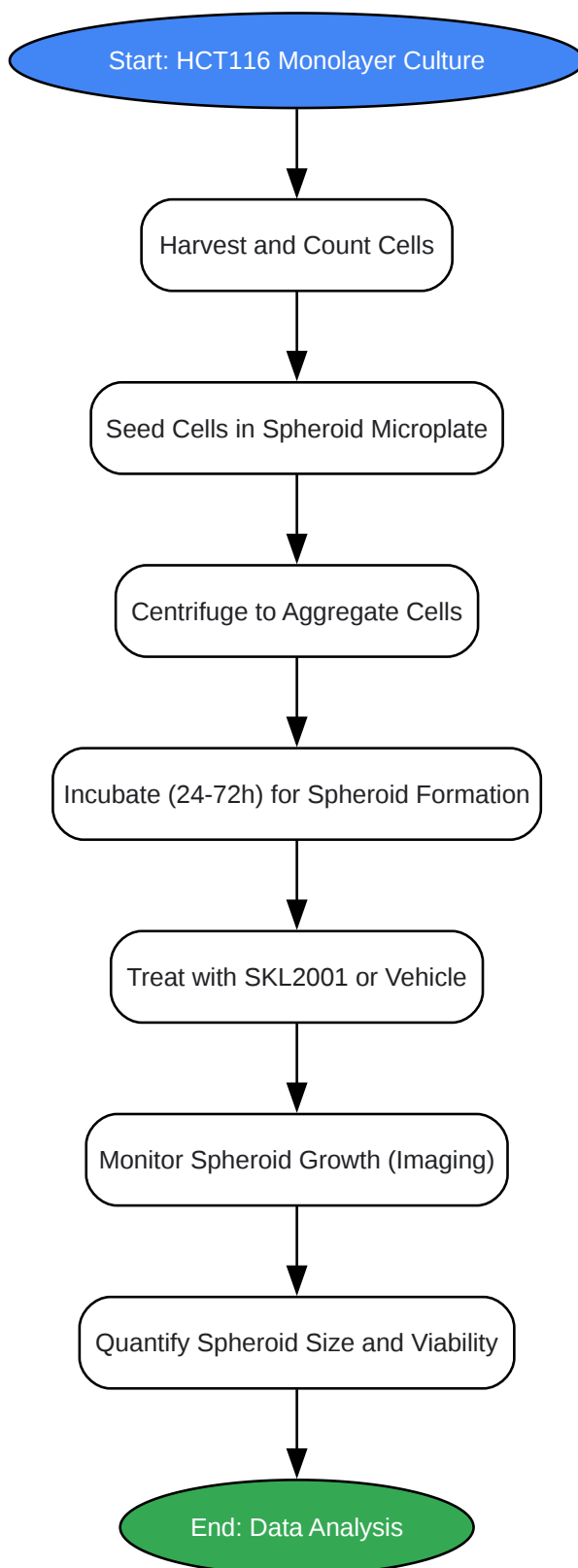

[Click to download full resolution via product page](#)

Caption: 3D Spheroid Culture and Treatment Workflow.

Luciferase Reporter Assay for Wnt/ β -catenin Signaling

This protocol is based on standard luciferase reporter assays for Wnt signaling.[\[10\]](#)[\[11\]](#)[\[12\]](#)[\[13\]](#)
[\[14\]](#)

Materials:

- HEK293T cells (or other suitable cell line)
- TOPFlash/FOPFlash reporter plasmids (TCF/LEF responsive luciferase reporter and a negative control)
- Renilla luciferase plasmid (for normalization)
- Transfection reagent (e.g., Lipofectamine)
- DMEM with 10% FBS
- **SKL2001**
- Dual-Luciferase® Reporter Assay System
- Luminometer

Procedure:

- Co-transfect HEK293T cells with TOPFlash (or FOPFlash) and Renilla luciferase plasmids using a suitable transfection reagent.
- 24 hours post-transfection, treat the cells with various concentrations of **SKL2001** or a vehicle control (DMSO).
- After the desired incubation period (e.g., 15-24 hours), lyse the cells using the passive lysis buffer provided in the Dual-Luciferase® Reporter Assay System.
- Measure the firefly luciferase activity in the cell lysate using a luminometer.
- Subsequently, measure the Renilla luciferase activity in the same sample.

- Normalize the firefly luciferase activity to the Renilla luciferase activity to account for variations in transfection efficiency and cell number.
- Express the results as fold induction over the vehicle-treated control.

Co-Immunoprecipitation of Axin and β -catenin

This protocol is adapted from methods used to study the Axin/ β -catenin interaction.[2][15][16]

Materials:

- HEK293 cells
- Plasmids for expressing tagged Axin and β -catenin (e.g., Myc-Axin and HA- β -catenin)
- Transfection reagent
- Cell lysis buffer (e.g., RIPA buffer with protease and phosphatase inhibitors)
- Antibody against one of the tags (e.g., anti-Myc antibody)
- Protein A/G agarose beads
- Wash buffer
- SDS-PAGE sample buffer
- Antibody against the other tag (e.g., anti-HA antibody) for Western blotting

Procedure:

- Co-transfect HEK293 cells with plasmids expressing tagged Axin and β -catenin.
- 24 hours post-transfection, treat the cells with **SKL2001** or a vehicle control for the desired time.
- Lyse the cells in cold lysis buffer.
- Clarify the cell lysates by centrifugation.

- Incubate the supernatant with an antibody against one of the protein tags (e.g., anti-Myc for Axin) to form an antibody-antigen complex.
- Add Protein A/G agarose beads to the lysate to capture the antibody-antigen complex.
- Wash the beads several times with wash buffer to remove non-specific binding proteins.
- Elute the protein complexes from the beads by boiling in SDS-PAGE sample buffer.
- Analyze the eluted proteins by Western blotting using an antibody against the other protein tag (e.g., anti-HA for β -catenin).

Western Blotting

This is a general protocol for analyzing protein expression levels.[\[17\]](#)[\[18\]](#)[\[19\]](#)[\[20\]](#)

Materials:

- Treated HCT116 cells (from 2D or 3D culture)
- RIPA buffer with protease and phosphatase inhibitors
- BCA protein assay kit
- SDS-PAGE gels
- PVDF membrane
- Transfer buffer
- Blocking buffer (e.g., 5% non-fat milk or BSA in TBST)
- Primary antibodies (e.g., anti- β -catenin, anti-E-cadherin, anti-c-myc, anti-GAPDH)
- HRP-conjugated secondary antibodies
- ECL Western blotting substrate
- Chemiluminescence imaging system

Procedure:

- Lyse the cells in RIPA buffer and determine the protein concentration using a BCA assay.
- Denature equal amounts of protein from each sample by boiling in SDS-PAGE sample buffer.
- Separate the proteins by SDS-PAGE.
- Transfer the separated proteins to a PVDF membrane.
- Block the membrane in blocking buffer for 1 hour at room temperature.
- Incubate the membrane with the primary antibody overnight at 4°C.
- Wash the membrane with TBST.
- Incubate the membrane with the HRP-conjugated secondary antibody for 1 hour at room temperature.
- Wash the membrane with TBST.
- Add ECL substrate and detect the chemiluminescent signal using an imaging system.
- Quantify the band intensities and normalize to a loading control (e.g., GAPDH).

Cell Cycle Analysis by Flow Cytometry

This protocol is based on standard methods for cell cycle analysis.[\[21\]](#)[\[22\]](#)[\[23\]](#)

Materials:

- Treated HCT116 cells
- PBS
- Cold 70% ethanol
- Propidium Iodide (PI) staining solution containing RNase A

- Flow cytometer

Procedure:

- Harvest the treated cells and wash with PBS.
- Fix the cells by dropwise addition of cold 70% ethanol while vortexing, and incubate at -20°C for at least 2 hours.
- Wash the fixed cells with PBS to remove the ethanol.
- Resuspend the cells in PI staining solution and incubate in the dark for 30 minutes at room temperature.
- Analyze the DNA content of the cells using a flow cytometer.
- Use cell cycle analysis software to determine the percentage of cells in the G0/G1, S, and G2/M phases of the cell cycle.

Conclusion

SKL2001 presents a fascinating case of a Wnt/ β -catenin pathway agonist with context-dependent anti-cancer properties. Its ability to inhibit the growth of colon cancer spheroids by inducing cell cycle arrest and upregulating E-cadherin suggests that the simplistic view of Wnt activation being solely pro-tumorigenic requires refinement. The experimental protocols detailed in this guide provide a framework for researchers to further investigate the paradoxical activities of **SKL2001** and to explore the therapeutic potential of nuanced Wnt pathway modulation in cancer. Further studies are warranted to establish a comprehensive profile of **SKL2001**'s efficacy across a broader range of cancer types and to elucidate the precise molecular determinants of its anti-proliferative effects in 3D tumor models. The lack of extensive in vivo data remains a significant gap, and future research should prioritize the evaluation of **SKL2001** in relevant animal models of cancer.

Need Custom Synthesis?

BenchChem offers custom synthesis for rare earth carbides and specific isotopic labeling.

Email: info@benchchem.com or [Request Quote Online](#).

References

- [1. Flow cytometric analysis identifies changes in S and M phases as novel cell cycle alterations induced by the splicing inhibitor isoginkgetin | PLOS One \[journals.plos.org\]](#)
- [2. Small molecule-based disruption of the Axin/ \$\beta\$ -catenin protein complex regulates mesenchymal stem cell differentiation - PMC \[pmc.ncbi.nlm.nih.gov\]](#)
- [3. 3D Cell Culture of Human Colon Cancer Cells \(HCT116\) on VitroGel® System | TheWell Bioscience \[thewellbio.com\]](#)
- [4. SKL2001 suppresses colon cancer spheroid growth through regulation of the E-cadherin/ \$\beta\$ -Catenin complex - PubMed \[pubmed.ncbi.nlm.nih.gov\]](#)
- [5. medchemexpress.com \[medchemexpress.com\]](#)
- [6. medchemexpress.com \[medchemexpress.com\]](#)
- [7. corning.com \[corning.com\]](#)
- [8. thewellbio.com \[thewellbio.com\]](#)
- [9. Maintenance of HCT116 colon cancer cell line conforms to a stochastic model but not a cancer stem cell model - PMC \[pmc.ncbi.nlm.nih.gov\]](#)
- [10. resources.amsbio.com \[resources.amsbio.com\]](#)
- [11. Protocol for a Wnt reporter assay to measure its activity in human neural stem cells derived from induced pluripotent stem cells - PMC \[pmc.ncbi.nlm.nih.gov\]](#)
- [12. med.emory.edu \[med.emory.edu\]](#)
- [13. protocols.io \[protocols.io\]](#)
- [14. assaygenie.com \[assaygenie.com\]](#)
- [15. Domains of Axin Involved in Protein–Protein Interactions, Wnt Pathway Inhibition, and Intracellular Localization - PMC \[pmc.ncbi.nlm.nih.gov\]](#)
- [16. assaygenie.com \[assaygenie.com\]](#)
- [17. researchgate.net \[researchgate.net\]](#)
- [18. Wnt Signaling and Cadherin Expressions in Different Staging of Colorectal Cancer as Biomarkers for Metastasis: Study of SW480, COLO 320DM, and HCT116 Cellines | Open Access Macedonian Journal of Medical Sciences \[oamjms.eu\]](#)
- [19. pdfs.semanticscholar.org \[pdfs.semanticscholar.org\]](#)
- [20. \$\beta\$ -catenin activation down-regulates cell-cell junction-related genes and induces epithelial-to-mesenchymal transition in colorectal cancers - PubMed](#)

[\[pubmed.ncbi.nlm.nih.gov\]](https://pubmed.ncbi.nlm.nih.gov)

- [21. researchgate.net \[researchgate.net\]](https://researchgate.net)
- [22. researchgate.net \[researchgate.net\]](https://researchgate.net)
- [23. Assaying cell cycle status using flow cytometry - PMC \[pmc.ncbi.nlm.nih.gov\]](https://pmc.ncbi.nlm.nih.gov)
- To cite this document: BenchChem. [Investigating the Anti-Cancer Activity of SKL2001: A Technical Guide]. BenchChem, [2026]. [Online PDF]. Available at: [\[https://www.benchchem.com/product/b15545171/docs#investigating-the-anti-cancer-activity-of-skl2001-a-technical-guide\]](https://www.benchchem.com/product/b15545171/docs#investigating-the-anti-cancer-activity-of-skl2001-a-technical-guide)

Disclaimer & Data Validity:

The information provided in this document is for Research Use Only (RUO) and is strictly not intended for diagnostic or therapeutic procedures. While BenchChem strives to provide accurate protocols, we make no warranties, express or implied, regarding the fitness of this product for every specific experimental setup.

Technical Support: The protocols provided are for reference purposes. Unsure if this reagent suits your experiment?

Need Industrial/Bulk Grade? [Request Custom Synthesis Quote](#)

BenchChem

Our mission is to be the trusted global source of essential and advanced chemicals, empowering scientists and researchers to drive progress in science and industry.

Contact

Address: 3281 E Guasti Rd
Ontario, CA 91761, United States
Phone: (601) 213-4426
Email: info@benchchem.com

[Contact our Ph.D. Support Team for a compatibility check](#)

