

Commercial Sources and Availability of Ospemifene-d4: A Technical Guide

Author: BenchChem Technical Support Team. **Date:** April 2026

Compound of Interest

Compound Name: *Ospemifene-d4*

Cat. No.: *B15545300*

[Get Quote](#)

For Researchers, Scientists, and Drug Development Professionals

This technical guide provides an in-depth overview of the commercial sources, availability, and key technical data for **Ospemifene-d4**. This deuterated analog of Ospemifene serves as a critical internal standard for its quantification in various biological matrices, facilitating pharmacokinetic and metabolic studies.

Commercial Availability

Ospemifene-d4 is available from several specialized chemical suppliers. The following table summarizes the offerings from prominent vendors. Please note that pricing and stock availability are subject to change and should be verified directly with the suppliers.

Supplier	Catalog Number	Purity	Available Unit Sizes	Price (USD)
Simson Pharma Limited	-	Certificate of Analysis provided	Contact for details	Contact for quote
Sussex Research Laboratories Inc.	SI150070	>95% (HPLC), >95% Isotopic Enrichment	5 mg, 10 mg, 25 mg	\$1,350.00 (for 25mg)
Lotusfeet Pharma	LF-O000427	-	Contact for details	Contact for quote
Veeprho	DVE001159	-	Contact for details	Contact for quote
Cayman Chemical	-	≥99% deuterated forms (d1-d4)	Contact for details	Contact for quote
AXEL	461663	Highly Purified	2.5mg	¥119,000

Synthesis and Manufacturing

The synthesis of **Ospemifene-d4** typically involves the introduction of deuterium atoms into the ethanol moiety of the Ospemifene molecule. A plausible synthetic route is adapted from the known synthesis of Ospemifene.

Proposed Synthetic Pathway

A likely synthetic route for **Ospemifene-d4** would involve the reaction of a suitable precursor with a deuterated reagent. For instance, (Z)-4-(4-chloro-1,2-diphenylbut-1-enyl)phenol could be reacted with a deuterated 2-haloethanol (e.g., 2-bromoethanol-d4) in the presence of a base to yield **Ospemifene-d4**.

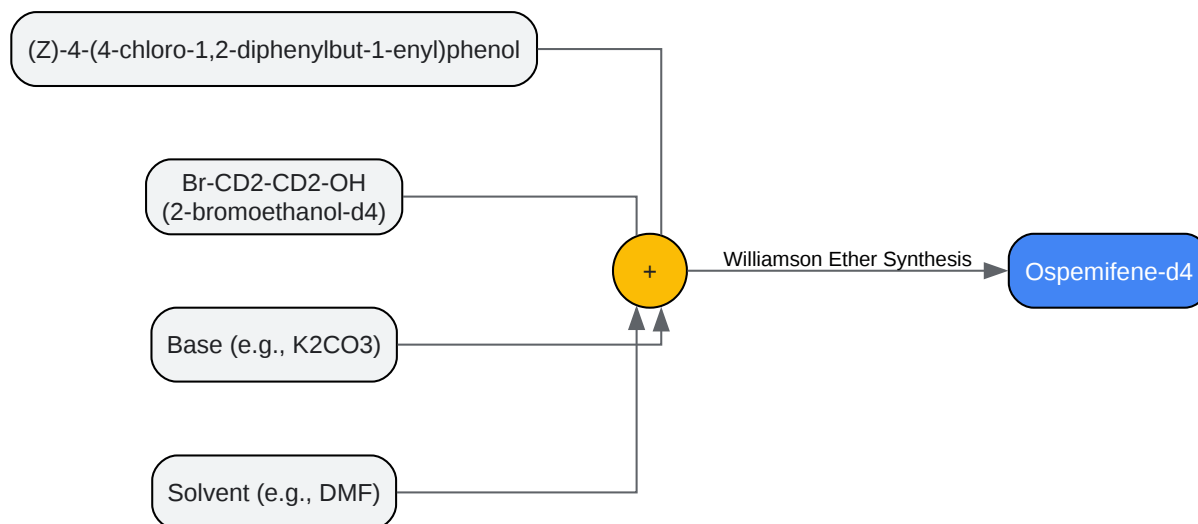

[Click to download full resolution via product page](#)

A proposed synthetic route for **Ospemifene-d₄**.

Experimental Protocols

Analytical Method for Quantification of Ospemifene using Ospemifene-d₄

A highly sensitive and specific liquid chromatography-tandem mass spectrometry (LC-MS/MS) method has been developed for the determination of Ospemifene in human plasma, utilizing **Ospemifene-d₄** as an internal standard.^{[1][2][3]}

1. Sample Preparation (Solid-Phase Extraction)^{[1][2]}

- Extraction Cartridges: Phenomenex Strata X-33 μm polymeric sorbent cartridges (30 mg/1 mL).
- Procedure:
 - Condition the cartridges with methanol followed by water.
 - Load the plasma sample (pre-spiked with **Ospemifene-d₄** internal standard).

- Wash the cartridges to remove interferences.
- Elute the analyte and internal standard with a suitable organic solvent.
- Evaporate the eluate to dryness and reconstitute in the mobile phase.

2. LC-MS/MS System and Conditions^{[1][2]}

- Liquid Chromatograph: Agilent or equivalent HPLC system.
- Mass Spectrometer: API-4500 MS/MS or equivalent.
- Analytical Column: Agilent Eclipse XDB-Phenyl, 4.6 × 75 mm, 3.5 μm.^{[1][2]}
- Mobile Phase: Methanol and 20 mM ammonium formate buffer (90:10, v/v).^{[1][2]}
- Flow Rate: 0.9 mL/min.^{[1][2]}
- Ionization Mode: Electrospray Ionization (ESI) in positive ion mode.
- Detection: Multiple Reaction Monitoring (MRM).

3. Method Validation

- The method should be validated according to FDA guidelines, demonstrating linearity, accuracy, precision, and stability. A linear calibration curve over the concentration range of 5.02-3025 ng/mL has been reported.^{[1][2]}

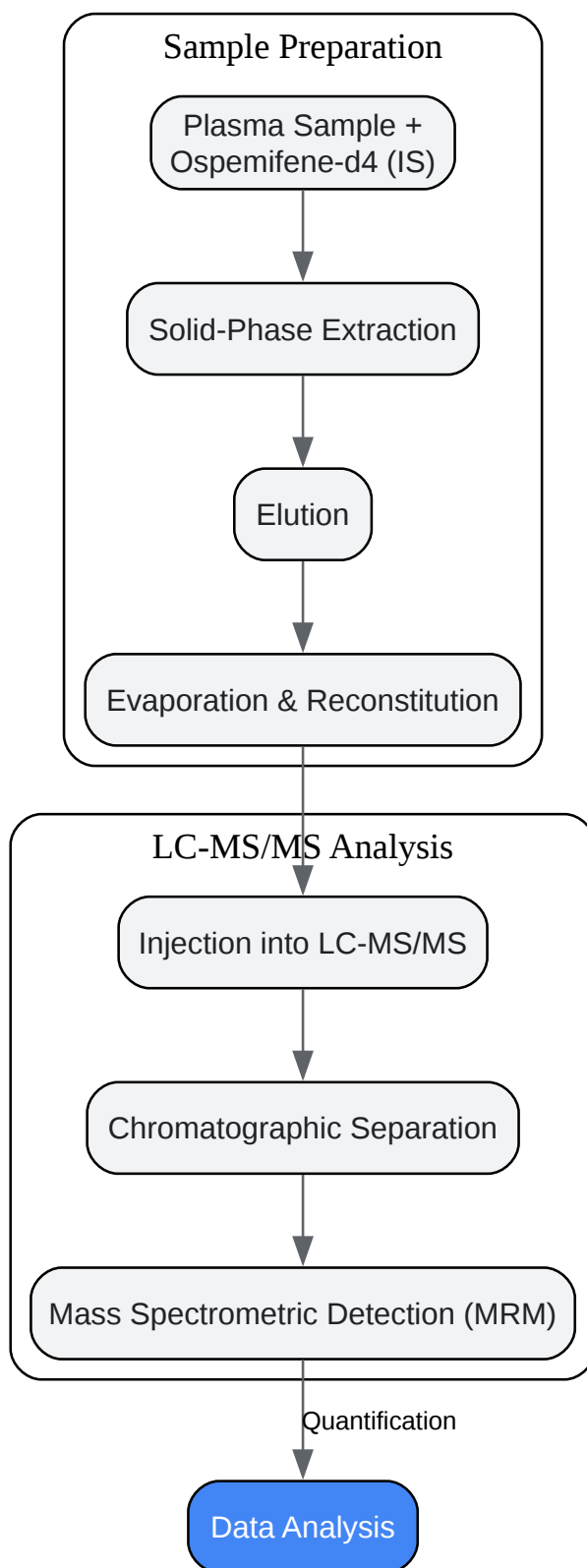

[Click to download full resolution via product page](#)

Workflow for the quantification of Ospemifene using **Ospemifene-d4**.

Mechanism of Action and Signaling Pathway

Ospemifene is a selective estrogen receptor modulator (SERM).[4] Its biological effects are mediated through binding to estrogen receptors (ER α and ER β), leading to tissue-selective agonist or antagonist activities.[5]

- **Vaginal Tissue (Agonist Effect):** In the vaginal epithelium, Ospemifene acts as an estrogen agonist.[5] This action restores the vaginal epithelium, increases lubrication, and improves tissue elasticity and thickness.[5]
- **Bone (Agonist Effect):** Ospemifene exhibits estrogenic effects on bone, which can contribute to maintaining bone density.[5]
- **Breast and Endometrium (Antagonist/Mixed Agonist Effect):** In breast tissue, it has an antagonistic effect, counteracting the proliferative effects of estrogen.[5] In the endometrium, it does not stimulate proliferation to the same extent as estrogen.[5]

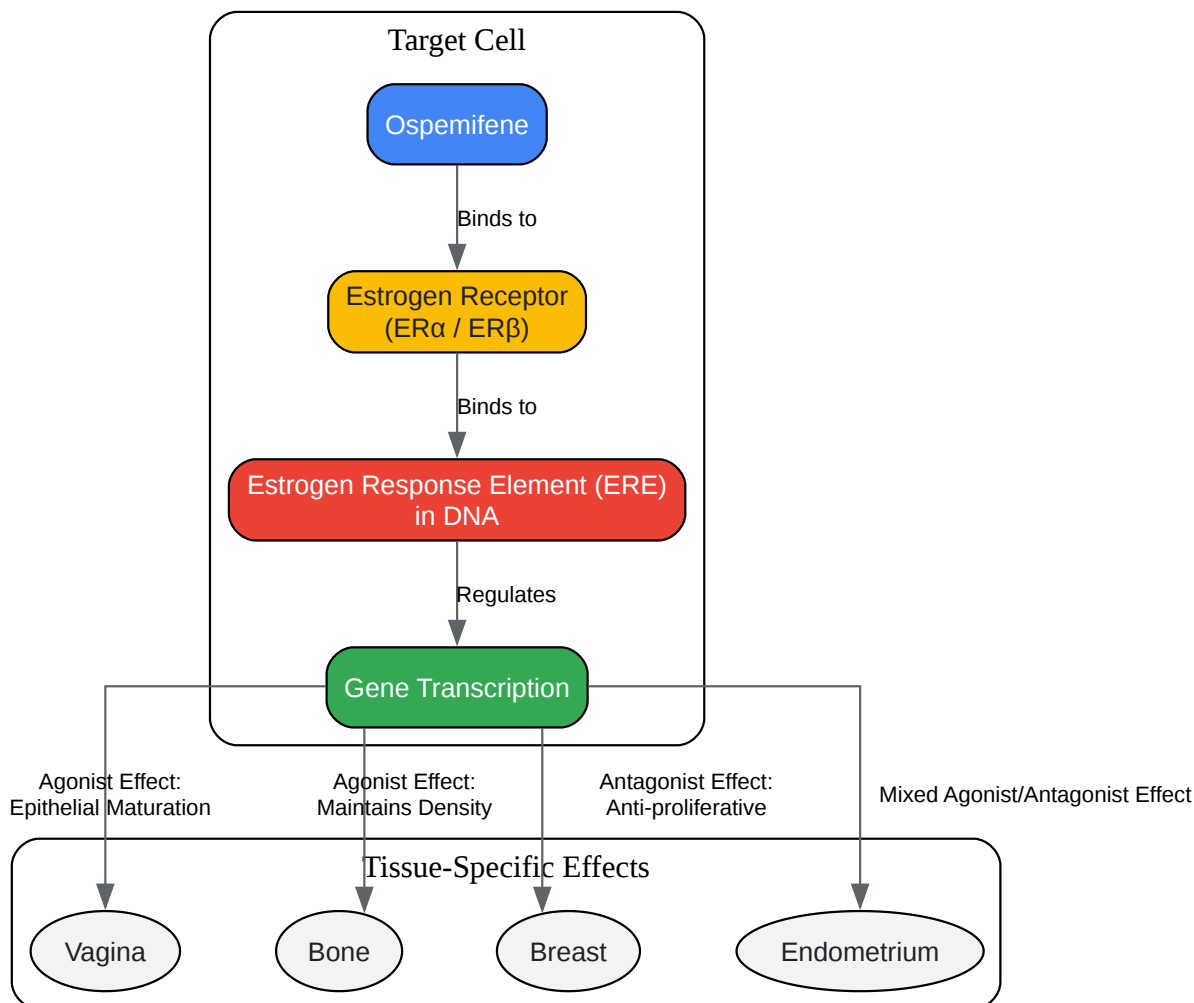

[Click to download full resolution via product page](#)

Signaling pathway of Ospemifene as a SERM.

Need Custom Synthesis?

BenchChem offers custom synthesis for rare earth carbides and specific isotopic labeling.

Email: info@benchchem.com or [Request Quote Online](#).

References

- [1. Determination of ospemifene in human plasma by LC-MS/MS and its application to a human pharmacokinetic study - PubMed \[pubmed.ncbi.nlm.nih.gov\]](#)
- [2. researchgate.net \[researchgate.net\]](#)
- [3. Determination of ospemifene in human plasma by LC-MS/MS and its application to a human pharmacokinetic study. \(2018\) | Siva Sankara Rao Yadlapalli | 1 Citations \[scispace.com\]](#)
- [4. go.drugbank.com \[go.drugbank.com\]](#)
- [5. What is the mechanism of Ospemifene? \[synapse.patsnap.com\]](#)
- [To cite this document: BenchChem. \[Commercial Sources and Availability of Ospemifene-d4: A Technical Guide\]. BenchChem, \[2026\]. \[Online PDF\]. Available at: \[https://www.benchchem.com/product/b15545300/docs#commercial-sources-and-availability-of-ospemifene-d4-a-technical-guide\]](#)

Disclaimer & Data Validity:

The information provided in this document is for Research Use Only (RUO) and is strictly not intended for diagnostic or therapeutic procedures. While BenchChem strives to provide accurate protocols, we make no warranties, express or implied, regarding the fitness of this product for every specific experimental setup.

Technical Support: The protocols provided are for reference purposes. Unsure if this reagent suits your experiment?

Need Industrial/Bulk Grade? [Request Custom Synthesis Quote](#)

BenchChem

Our mission is to be the trusted global source of essential and advanced chemicals, empowering scientists and researchers to drive progress in science and industry.

Contact

Address: 3281 E Guasti Rd
Ontario, CA 91761, United States
Phone: (601) 213-4426
Email: info@benchchem.com

Contact our Ph.D. Support Team for a compatibility check