

Application Notes and Protocols for SKL2001 Powder

Author: BenchChem Technical Support Team. **Date:** April 2026

Compound of Interest

Compound Name: SKL2001
Cat. No.: B15545171

[Get Quote](#)

For Researchers, Scientists, and Drug Development Professionals

Product Information

SKL2001 is a small molecule agonist of the Wnt/ β -catenin signaling pathway.[1][2] It functions by stabilizing intracellular β -catenin through the disruption of the Axin/ β -catenin interaction.[1][2][3] This mechanism prevents the phosphorylation and subsequent proteasomal degradation of β -catenin, leading to its accumulation and the activation of downstream gene transcription.[2][4] **SKL2001** has been utilized in research to promote osteoblast differentiation and suppress adipocyte differentiation.[5]

Chemical and Physical Properties

SKL2001 is a cell-permeable imidazolyl-isoxazolamide compound. Its key properties are summarized below.

Property	Value	References
Chemical Name	5-(Furan-2-yl)-N-(3-(1H-imidazol-1-yl)propyl)-1,2-oxazole-3-carboxamide	
Synonyms	Wnt Agonist II	
CAS Number	909089-13-0	[1][6]
Molecular Formula	C ₁₄ H ₁₄ N ₄ O ₃	[6]
Molecular Weight	286.29 g/mol	[2][6]
Purity	>95-99% (HPLC)	[6]
Appearance	Solid, Pink-Red Powder	

Mechanism of Action: Wnt/ β -Catenin Pathway Activation

SKL2001 activates the canonical Wnt/ β -catenin signaling pathway. In the absence of a Wnt ligand, a "destruction complex" (comprising Axin, APC, GSK-3 β , and CK1) phosphorylates β -catenin, targeting it for ubiquitination and proteasomal degradation.[2][4] **SKL2001** physically disrupts the interaction between Axin and β -catenin.[2][7] This action prevents the phosphorylation of β -catenin at key serine and threonine residues (Ser33/37/Thr41 and Ser45), leading to its stabilization and accumulation in the cytoplasm and nucleus.[2][4] Nuclear β -catenin then associates with TCF/LEF transcription factors to activate the expression of Wnt target genes, such as Axin2.[1][6] Notably, **SKL2001**'s activity is independent of GSK-3 β inhibition.[2][5]

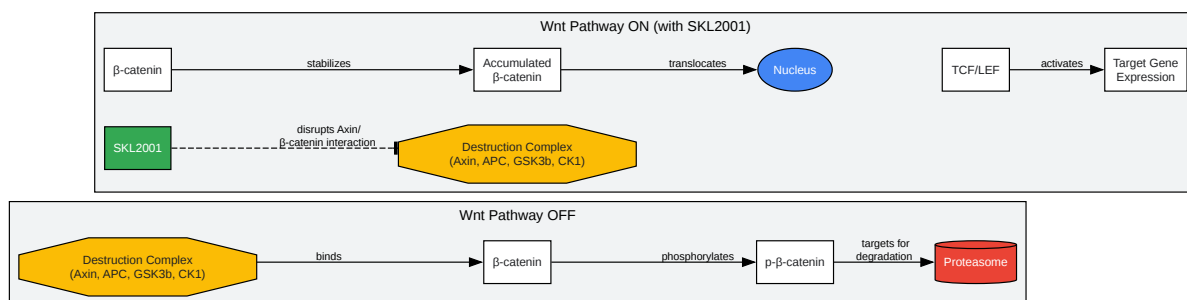

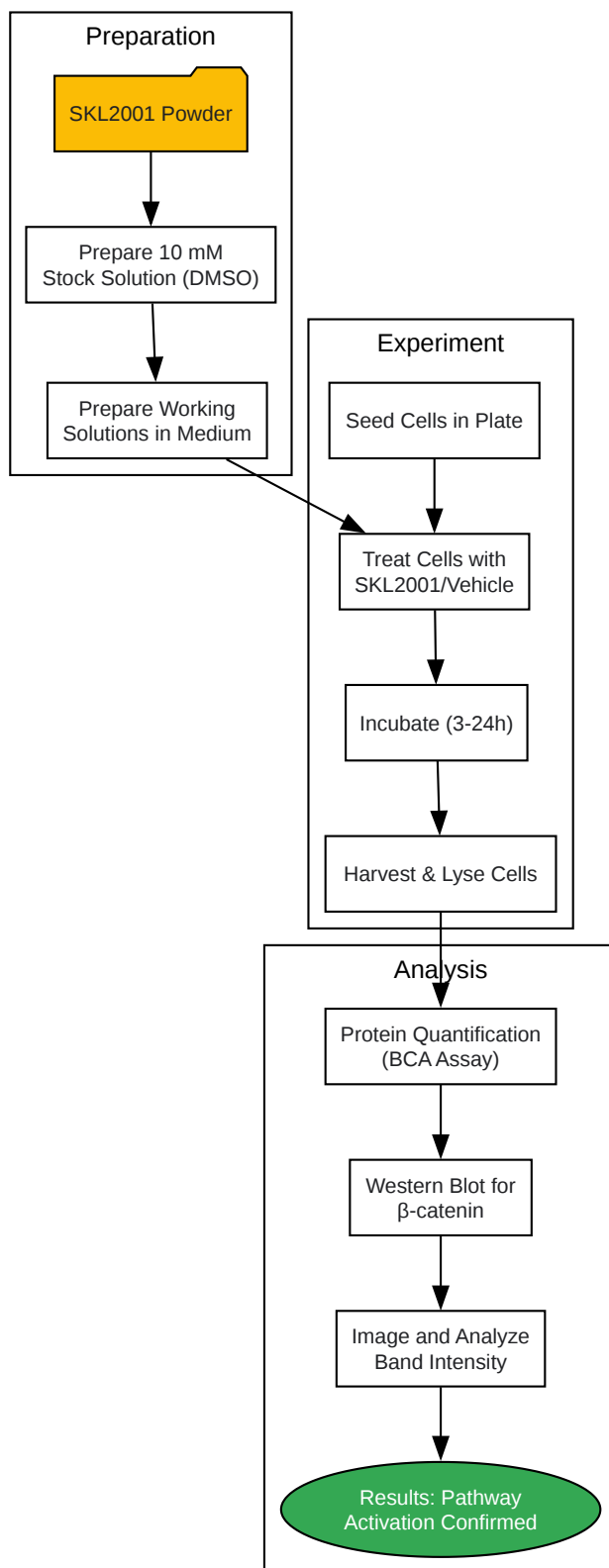

[Click to download full resolution via product page](#)

Need Custom Synthesis?

BenchChem offers custom synthesis for rare earth carbides and specific isotopic labeling.

Email: info@benchchem.com or [Request Quote Online](#).

References

- [1. medchemexpress.com \[medchemexpress.com\]](https://www.medchemexpress.com)
- [2. selleckchem.com \[selleckchem.com\]](https://www.selleckchem.com)
- [3. medchemexpress.com \[medchemexpress.com\]](https://www.medchemexpress.com)
- [4. Small molecule-based disruption of the Axin/ \$\beta\$ -catenin protein complex regulates mesenchymal stem cell differentiation - PMC \[pmc.ncbi.nlm.nih.gov\]](#)
- [5. researchgate.net \[researchgate.net\]](https://www.researchgate.net)
- [6. SKL2001 | 909089-13-0 | Beta-catenin | MOLNOVA \[molnova.com\]](#)
- [7. SKL2001 | Wnt/beta-catenin 抑制剂 | 现货供应 | 美国品牌 | 免费采购电话400-668-6834 \[selleck.cn\]](#)
- To cite this document: BenchChem. [Application Notes and Protocols for SKL2001 Powder]. BenchChem, [2026]. [Online PDF]. Available at: [\[https://www.benchchem.com/product/b15545171/docs#application-notes-and-protocols-for-skl2001-powder\]](https://www.benchchem.com/product/b15545171/docs#application-notes-and-protocols-for-skl2001-powder)

Disclaimer & Data Validity:

The information provided in this document is for Research Use Only (RUO) and is strictly not intended for diagnostic or therapeutic procedures. While BenchChem strives to provide accurate protocols, we make no warranties, express or implied, regarding the fitness of this product for every specific experimental setup.

Technical Support: The protocols provided are for reference purposes. Unsure if this reagent suits your experiment?

Need Industrial/Bulk Grade? [Request Custom Synthesis Quote](#)

BenchChem

Our mission is to be the trusted global source of essential and advanced chemicals, empowering scientists and researchers to drive progress in science and industry.

Contact

Address: 3281 E Guasti Rd
Ontario, CA 91761, United States
Phone: (601) 213-4426
Email: info@benchchem.com

[Contact our Ph.D. Support Team for a compatibility check](#)